

Heisey News

The Official Publication of Heisey Collectors of America



CONVENTION, ELECTIONS & MORE

INSIDE: Page 6: Membership Meeting Overview and Amendment Proposals;

Page 11: Research and Archives Committee Report; Page 12: Meet the Board Candidates;

Page 14: Heisey Convention Schedule; Page 15: Heisey Convention Registration Form;

Page 17: NEW! Heisey Candlestick, Candelabra and, Lamps Reference Book Revised Edition is Available for Preorder

Heisey Collectors Of America, Inc.

169 W. Church Street
Newark, Ohio 43055
Phone: 740-345-2932
Fax: 740-345-9638
www.HeiseyMuseum.org

Co-Executive Directors

Jennifer Miller: 740-345-2932, ext. 3
business@heiseymuseum.org

Cheryl Varrasso: 740-345-2932, ext. 5
CVarrasso@heiseymuseum.org

Newsletter

Kirk Homrighouse, Assistant Editor
740-345-2932, ext. 2
KHomrighouse@heiseymuseum.org

Member Guest Services

Email: Clerk@heiseymuseum.org
Tina Wells, Guest Services, ext. 2
Janet Brewer, Guest Services, ext. 2
Elizabeth Bowman, Guest Services ext. 2
Tracy Shively, Guest Services, ext. 2
Diana Ronan, Guest Services, ext. 2

Auction Firm Manager

Roy Eggert; 240-361-8146
auction@heiseymuseum.org

National Heisey Glass Museum

Heisey Collectors of America, Inc., a non-profit corporation (tax-exempt status), owns and operates the National Heisey Glass Museum.

Museum Hours:

Tuesday through Saturday
10 a.m. to 4 p.m.
Closed Sunday through Monday and
Holidays

Members admitted free.

Regular admission \$5.

(children 18 and under free)



Important Dates

**2024 Heisey National Convention
and Glass Show
June 13-15, 2024
Newark, Ohio**

**2024 Annual Dick Marsh
Memorial Car Show
To Benefit the Heisey Museum
July 28, 2024 - 11am-3pm**

**Dave Spahr Fall Select Auction
October 19, 2024
Newark, Ohio**



*On the cover:
Spring brings a
pop of color to the
elegant entryway
of the Heisey
National Glass
Museum.*

Index:

- Page 3: President's Message-Suzanne Parker**
- Page 4: HCA and Museum Updates**
- Page 5: Treasurer's Report**
- Page 6: Membership Meeting Overview and Summary of Proposed Amendments**
- Page 7: Proposal #1: Voting Membership**
- Page 10: Proposal #2: Reform Personnel Management**
- Page 11: Research and Archives Committee Report**
- Page 12: Meet the Board Candidates**
- Page 14: Heisey Convention Schedule**
- Page 15: Heisey Convention Registration Form**
- Page 17: NEW! Heisey Candlestick, Candelabra and, Lamps Reference Book Revised Edition is Available for Preorder!**
- Page 18: In Fond Memory**
- Page 20: Dick Marsh Memorial Car Show**
- Page 22: Heisey in the Museum Shop**
- Page 24: New Members, Volunteers and Information**
- Page 25: Study Club Directory**
- Page 27: Dealer Directory**

HCA Board of Directors

President

Suzanne Parker
Manassas, VA
703-472-1614
parkerssw@aol.com

Vice President

Frachele Scott
Elizabeth City, NC
919-384-5159
frachele@gmail.com

Secretary

Mary Olson
St. Paul, MN
612-597-1284
molson@heiseymuseum.org

Treasurer

Caleb-Michael Files
Washington, D.C.
202-271-9501
cmfiles@heiseymuseum.org

Immediate Past President

Charlie Wade
Sun City West, AZ
740-328-7027
cswade418@gmail.com

Andy Baldus
Silver Spring, MD
301-213-9088
andybald99@verizon.net

David Eric Blair
Zanesville, OH
818-470-6900
glassguy1@yahoo.com

Jim Cooke
Beaverton, OR
503-645-3385
heiseyhunter@comcast.net

Bari Fauss
Bethel Park, PA
703-282-2215
barkar24@msn.com

Jay Goletz
Newark, OH
740-345-9307
goletzjir@gmail.com

Martha McGill
Solana Beach, CA
619-993-1897
heiseylady@gmail.com

Eric Tankesley-Clarke
California, MO
573-796-3829
heiseyglass@gmail.com

James Warren
St. Petersburg, FL
239-595-0084
jameswarrengroup@gmail.com

Message from the President



Are you counting the days until the convention? The show and sale, always the highlight of the convention, promises to be more spectacular than ever. Lisa Baldus and Lori Stillman have worked tirelessly to transform The Skylight into a sparkling showroom of beautiful glass.

The convention committee is collecting items for both the silent and live auctions. Do you have a duplicate piece of Heisey, or a pattern you no longer collect that you would be willing to donate? All funds raised from these auctions are earmarked for the HCA operating account. Let us know of your donation and we will send you a donation form. The more items donated, the more interesting the auctions become.

The Special Projects committee will be highlighting a new line of “Made from Heisey” jewelry that will be unveiled during the convention. Two styles of earrings will be offered. Traditional ball stud and flower design pierced earrings will be available in assorted Heisey colors. Limited amounts of each are being produced, so do not hesitate to stop by the museum shop during the convention to make your purchase. Remember gift cards are always available for any item in the shop either digital or physical. If you have any broken pieces of Flamingo or Dawn that you would like to contribute to this project, please bring or mail to the museum.

The gift shop will also be offering another item for your “need to have” list while you are at convention. The updated *Heisey Candlesticks Candelabra & Lamps* reference book, which includes more than 50 pages of new material, will be making its debut during the convention. Many thanks to Eric Tankesley-Clarke and the Education Committee for making this book available for sale once again.

The Properties Committee has overseen the completion of the installation of a camera monitoring 55" TV screen for the museum's security system. All 16 cameras are displayed on the monitor. Staff have commented that it is especially useful to keep track of people as they are moving from one level or gallery to the next. Much gratitude to Jay Goletz and Dick Smith for their help in completing this project. HCA would be amiss if we did not give a huge thank you to Robert Loch and Robert Harrison for their generous donations for the installation of a security system.

Nominating Committee Chair Charlie Wade recently announced three HCA members who have agreed to run for three board of director positions (see page 12 for nominee bios). Thank you to Darlene Cochran and Mary Cameron for serving on this committee. Be sure to read the candidates bio's and/or watch their video. Do not hesitate to reach out to ask questions as you meet the candidates at the convention.

HCA is most appreciative of everyone who bought items at the All-Heisey Spring Benefit Auction of Reproductions to benefit the Fundraising Committee's HVAC Replacement Campaign. The two days online and in-person SBA auction offered lively competition among friends over an item or two. These auctions would not be possible without the many volunteers who help during those two days. HCA thanks you.

Happy Spring. Fill those Heisey flower vases to the brim!



HCA Annual Meeting June 14

Heisey Collectors of America will hold its 2024 Annual Meeting on Friday morning, June 14, 9 a.m., in the lower level of the National Heisey Glass Museum.

HCA President Suzanne Parker will call the meeting to order and then immediately declare the polls open for the election of board members and voting on proposals to amend the HCA Constitution and Bylaws. Once the election has been completed, the meeting will continue with reports from the secretary and treasurer, announcements, and reports from study clubs.

Following the meeting, study clubs will have an opportunity to meet together and share ideas.

HCA and Museum Updates



Jennifer Miller, Cheryl Varrasso to serve as co-executive directors

HCA to involve all in developing strategic plan

by Frachele Scott, Vice President

After extensive consultation with search firms this past winter, the HCA Board of Directors has chosen **not** to hire a search firm to recruit our new executive director but to promote from within our existing museum staff.

The board appointed Jennifer Miller, our business manager and interim director, and Cheryl Varrasso, our gift shop manager, as co-executive directors effective May 1. They will maintain their current hourly schedule of full-time and halftime, respectively.

Each of the five firms we consulted gathered preliminary information via our website and through other internet searches before engaging in lengthy interviews to better understand our operations, budget, and goals. The free advice from these industry experts proved invaluable. In the end, they made it clear that HCA is not in a position at this time to attract candidates with education and experience in museum leadership.

Four of the five firms recommended that HCA first invest in working with consultants to develop a vision and strategic plan. We believe the assistance of a professional facilitator will likely yield satisfactory results as we involve our members, our museum staff, and our elected board in developing a vision and strategic plan.

In the meantime, the leadership qualities Jennifer and Cheryl have exhibited have given the board confidence in their ability to lead the museum together. This collaborative leadership approach is designed to leverage their unique strengths —Jennifer’s keen insight into business management and Cheryl’s expertise in museum operations and member engagement.

Cheryl came to the museum as a member guest service associate five years ago with extensive retail experience including designing displays, promotions, and hiring and training staff. While raising her family, she volunteered extensively in her children’s schools, organizing the parent-school organization, heading the band boosters, raising funds, and coordinating local and regional creative problem-solving competitions for 20 years. Her excellent work in the gift shop led the board to name her assistant gift shop manager and then gift shop manager.

Jennifer was hired as the museum’s financial coordinator June 2021 and promoted to business manager in December 2021. With the departure of the former executive director last summer, Jennifer was appointed interim director. She earned A.A. and B.A. degrees in art from The Ohio State University. Her major coursework included not only studio art and art history, but also art management and a number of courses in non-profit planning, organizing, managing, and fundraising, as well as courses in business management, administration, and economics. Since completing her degree, she has taken further courses in graphic design, applying design principles, marketing, and business analytics.

Prior to coming to the museum, she worked for Nader’s Insurance Agency in Newark, where she reorganized the company’s database, created office procedures, and managed the front office.

Please watch in the *Heisey News* and e-grams for opportunities to be involved in conversations around our vision and plan in the coming year.



***New National Heisey Glass
Museum co-executive director,
Jennifer Miller***



***New National Heisey Glass
Museum co-executive director,
Cheryl Varrasso***

Treasurer's Report by Caleb-Michael Files



HCA's 2024 total income has exceeded expectations, primarily bolstered by the strong performance of newsletter ads and generous cash donations.

On the expenditure side, we've successfully kept costs under budget. Savings have arisen from having no expenses in major non-recurring items, giving us a financial buffer to potentially invest in new initiatives.

This robust financial standing sets us up for future growth and sustainability. Thank you for your continued support and participation, which have been crucial to our success.

THANK YOU to those who donated to the Operating and other funds.
March 2024 Donations: \$2,638.00; total 2024 donations through March: \$3,408.00
2024 GOAL: \$20,000

Sharon Holihan- *In Memory of Mother Blanche*

Sharon Holihan- *In Memory of Susan Bruah*

Sharon Holihan

Eric Tankesley-Clarke

Mary Ann Spahr

Earle and Elaine Hart

Virginia D. and Everett A. Blodgett

Daniel Fitzgerald and Alice Zilley

Allan Lane

Michael Harris

Tracey Bowman

Brandon Pierce

Martha Alexander

Linda Lowe

Edward M. Morin and Cyndee H. Freeman

Virginia Pratt

Donald and Vicki Ensor - *In memory of Mr. Charles Lehman, husband of Sally Lehman*

Operating Fund Donations as of March 2024: \$3,408.00
2024 Goal: \$20,000

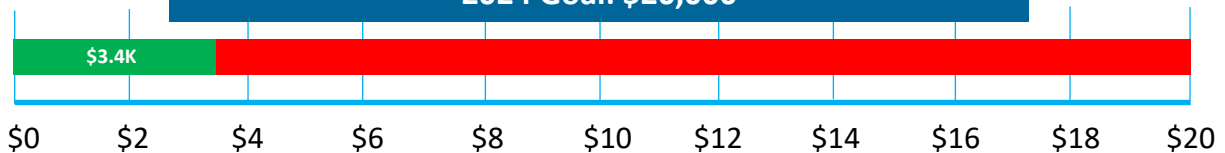

THANK YOU to those who donated to the Endowment Fund in March 2024.
March 2024 Donations: \$500.00; total 2024 donations through March: \$2,274.00

Dan Guckien

Benjamin Hart

Eric Tankesley-Clarke

Charlotte Bryan

Raeshel Seemann

Kathleen and Franklin Taylor

Virginia D. and Everett A. Blodgett

Edward M. Morin and Cyndee H. Freeman

HCA Membership Meeting 2024 Highlights

HCA Membership Meeting Focused on June Election

The upcoming election was the highlight of the first HCA Membership Meeting of 2024, held April 13 immediately prior to the start of the second day of the Spring Benefit Auction at the GMP Local 244 Union Hall in Newark.

Three seats on the HCA Board of Directors will be open in June when Bari Fauss, Jay Goletz and Suzanne Parker complete their four-year terms of office. On behalf of the Nominating Committee, President Suzanne Parker announced the slate of candidates for the Board of Directors: Mary Cameron*, Jay Goletz, who is running for a second term, and David Malick. HCA member Elizabeth Shirley nominated Bari Fauss, who accepted the nomination to run for a second term.

Martha McGill, chair of the Bylaws Committee, reviewed two proposed amendments. The first would eliminate the voting membership category, thus making all HCA members eligible to vote in HCA elections going forward. This motion had been presented to members last year. Though 57% had voted in favor, it did not meet the two-thirds threshold necessary for approval. Since the majority of voters favored the proposal, the Bylaws Committee and the board agreed it should be presented again for a vote. (See page 7).

The second proposal would reform personnel management practices by allocating responsibilities between the board and the director in a manner more consistent with modern business practices. The board would retain the responsibility of hiring and firing the director, determining the number of staff positions, and setting compensation. The director would be given the authority to hire and fire staff and to revise work assignments as necessary to operate the museum efficiently. (See page 10).

The board sent a third proposal back to the Bylaws Committee for further work. It would have given flexibility for the board to range in size from nine to 12 members. This was part of a larger proposal under development that included reducing board terms from four to three years and increasing the number of required board meetings from four to six each year. Martha emphasized that the proposal was **not** rejected; because these changes are significant, the board felt they should not be made in haste.

President Parker also announced that HCA has had thoughtful and fruitful discussions with several search firms regarding a search for a new executive director to lead the museum. All firms consulted gave a consistent message – before launching a search, HCA needs to make internal improvements, such as developing a strategic plan and vision. “The board is exploring a reorganization of our current staff to meet our needs as we develop our strategic plan and vision,” said Suzanne. Members can expect additional communication shortly.

*Mary Cameron later withdrew her nomination, leaving three candidates running for three seats.

SUMMARY OF PROPOSED AMENDMENTS

The HCA Board of Directors proposes two amendments to the HCA Constitution and/or Bylaws.

The first amendment proposal would eliminate the voting membership category, thus allowing all HCA members the opportunity to vote in HCA elections. (See more information in Membership Meeting article on this page (above.) Because this amendment would modify the constitution, a two-thirds majority vote in favor is required for this proposal to pass.

The second amendment proposal would reform personnel management practices by allocating responsibilities between the board and the director in a manner more consistent with modern business practices. This amendment would impact the bylaws, so only a simple majority is required for passage.

All voting members are eligible to vote on these proposals in the June election during the Annual Meeting. For those unable to vote in person, absentee ballots are available by contacting the museum: Membership@HeiseyMuseum.org or 740-345-2932.

The full text of the proposed amendments follows on pages 7 through 10.

PROPOSAL #1: VOTING MEMBERSHIP

CONSTITUTION

ARTICLE III

Membership

Section 1 There shall be ~~three kinds~~ **two categories** of membership, namely:
~~Voting~~
Associate Members
Honorary

Section 2 ~~3~~ Associate Membership

Any person, upon payment of the prescribed dues, may become ~~an associate~~ **a** member of this organization. ~~Associate m~~ **Members are not permitted to vote or hold elective office, and they shall have no interest in any funds or property of the organization.**

Section 3 ~~4~~ Honorary Membership

Any person who has distinguished himself in an unusual and praiseworthy manner in promoting the objectives of this organization may be elected to honorary membership. Honorary members shall have the privilege of attending all meetings of the organization, but shall not be required to pay dues or initiation fees, or be permitted to vote or hold elective office, and they shall have no interest in any funds or property of the organization.

Section 4 ~~2~~ Voting Membership **by Chartered Study Clubs**

~~Any adult, age 18 or over, upon payment of the prescribed initiation fee and yearly dues, is eligible to become a voting member of this organization. Other qualifications shall be as stated in the Bylaws.~~

A study group (charter club) that fulfills requirements as set forth in the Bylaws is eligible to cast one vote in this organization by a member of that club who is of legal voting age. (approved 3/12/83)

Section 5 No territorial limits shall be established for the organization and membership is open to all interested persons.

ARTICLE VI

Board of Directors

Section 1 The Board of Directors shall consist of twelve (12) (approved 6/17/05) director selected by the ~~voting~~ members of the organization. Terms of office are to be as provided in the bylaws. (Note: See Bylaws Art. VII Sec.4)

Section 2 The Board of Directors shall be the governing body of the organization and shall have power to make such regulation and take such action, not inconsistent with the Constitution and Bylaws as, in its judgment, may be necessary for the welfare of the organization. The decisions of the Board in all organization matters shall be final, subject only to the appeal to the ~~voting~~ membership of the organization.

ARTICLE VIII

Surrender of Charter

Section 1 If this organization deems it desirable, by unanimous vote of the active ~~voting~~ membership, to terminate operation of this organization, all assets, records and monies shall be turned over to the Licking County Historical Society and that such shall be used for the study and preservation of Heisey glass and other such ancillary uses of the property as may be deemed necessary. In the event the Licking County Historical Society has been dissolved then such shall be turned over to the Ohio State Historical Society for the same purpose therein stated. (approved 12/15/73)

ARTICLE IX

Amendment of Constitution

Section 1 This Constitution may be amended only after recommendation by the Board of Directors and by a two-thirds vote cast of the ~~voting~~ members, voting at any meeting of the organization or as provided for in the Bylaws for absentee voting, provided written notice of such proposed amendment shall have been given to members at least ten days prior to the meeting at which the issue for amendment of the Constitution or Bylaws shall come up. (approved 3/11/95)

BYLAWS

ARTICLE I

Meetings

Section 4 Quorum

The majority of ~~voting~~ members present shall constitute a quorum at any meeting of the membership. (approved 3/11/95)

ARTICLE VII

Election of Directors

Section 1

- (a) The Directors of the organization shall be elected at the annual meeting each year.
- (b) At the second regular meeting of the calendar year, the President shall appoint a Nominating Committee of at least three members: the chairman shall be the immediate past President, then a ~~voting~~ member of the organization. If the immediate past President cannot serve, the chairman shall be another member of the Executive Committee, exclusive of the President. (approved 6/17/2011)
- (c) The Nominating Committee shall prepare a report giving the number of directors to be elected and one or more members for each vacancy.
- (d) After the report of the Nominating Committee at the first regular meeting of the calendar year and upon motion of any ~~voting~~ member, any name or names of candidates for Director shall be placed upon the ballot to be voted upon by the organization. (approved 3/11/95)
- (e) The consent of each nominee must be obtained prior to his or her nomination. (approved 3/11/95)
- (f) At the annual meeting there shall be furnished to the ~~voting~~ members a ballot containing the names of the nominees for Directors, upon which each ~~voting~~ member shall indicate his or her choices. If the number of nominees equals the number of Director vacancies, the ballot voting shall be deemed unnecessary if approved by the majority of the ~~voting~~ members present. (approved 6/17/2011)
- (g) In lieu of obtaining a ballot at the annual meeting, a ~~voting~~ member may obtain a ballot by applying to the secretary in advance of the annual meeting and may cast said ballot by returning it immediately to the secretary. (approved 3/11/95)

Section 2 Balloting

The nominees receiving the largest number of votes so cast shall be declared elected for the term of office beginning immediately following the annual meeting. The presiding officer shall abstain from voting except to break a tie vote. (approved 6/21/81)

Section 3 Election of Officers

Officers shall be elected as provided in Article V of the Constitution. (approved 3/17/73)

Section 4

The Board of Directors shall consist of 12 (approved 6/17/05) members elected from the roll of the ~~voting~~ members. (approved 3/11/95) The term of office shall be for four years. The number of consecutive four-year terms that a member may be elected to the Board of Directors shall be limited to two. (approved 6/20/82). To provide for the continuity of operation, three persons shall be elected each year. (approved 6/17/2011).

BYLAWS continued

ARTICLE VIII

Initiation Fees and Dues

~~Section 1 The Initiation Fee for voting membership in the organization shall be \$ 25.00 and shall be paid before the candidate can qualify as a voting member. Membership dues shall be as determined by the Board of Directors. (approved 3/11/95)~~

Section ~~1~~ ~~2~~ Associate Membership Dues

Membership dues shall be determined by the Board of Directors which shall include subscription to the organization newsletter and all rights and privileges as provided in the Constitution. Each additional household member is eligible to become a ~~a~~ associate member upon payment of prescribed dues per year. (approved 3/11/95)

Section ~~3~~ ~~2~~ Study group (charter club)

The requirements to establish and maintain a Study group (charter club) are:

- (a) All members must be ~~voting or associate~~ members of H.C.A.
- (b) Payment of a one-time \$25.00 fee
- (c) Annually submit a membership list to the Secretary of H.C.A. by May first
- (d) Have at least eight (8) members. (approved 3/12/83)
- (e) Written bylaws approved by HCA Board of Directors (approved 6/17/10)

Section ~~4~~ ~~3~~ All dues shall be payable when billed by the Treasurer. No person shall be deemed a member who is in arrears more than thirty (30) days in the payment of his or her dues. (approved 3/11/95)

ARTICLE XI

Amendment of Bylaws and Constitution

Section 1 The Constitution may be amended by a two-thirds majority vote of the ~~voting~~ members present and voting at any regular meeting of the organization or as provided for absentee voting herein, after recommendation of the Board of Directors, or by any twelve ~~voting~~ members, provided written notice of such proposed amendments shall have been given to all ~~voting~~ members at least ten days prior to the meeting. The Bylaws may be amended by a majority vote of the ~~voting~~ members present and voting at any regular meeting of the organization, or as provided for absentee voting herein, after recommendation of the Board of Directors, or by any twelve ~~voting~~ members, provided written notice of such proposed amendments shall have been given to all ~~voting~~ members at least ten days prior to the meeting. With such written notice shall be sent a copy of proposed change or changes and a form to be returned to the Secretary, which form shall provide the opportunity to ~~voting~~ members to indicate approval or disapproval of each recommended change; which form, to be counted, must be received by the Secretary c/o the Museum at least three days prior to the scheduled meeting at which the vote on the recommended change or changes is to occur. (approved 3/11/95)

No amendments or additions to these Bylaws shall be made which are not in conformity with the organization Constitution.



PROPOSAL #2: REFORM PERSONNEL MANAGEMENT

PRESENT:

ARTICLE IV

Paid Employees and Staff

Section 1 Paid Employees

The Executive Committee shall have authority to seek out, interview or examine and recommend to the Board of Directors persons to serve as paid employees in capacities as from time to time become necessary.

Such employees shall be hired and their intended compensation set by a two-thirds vote by the Board of Directors at a meeting wherein a quorum is present. (approved 3/11/95)

The compensation of such employees shall be reviewed by the Executive Committee from time to time and any changes recommended to the Board of Directors who shall pass upon such changes by a two-thirds vote of the Board of Directors at a meeting wherein a quorum is present.

Such employees may be terminated by the Board of Directors by a two-thirds vote of said Board of Directors at a meeting wherein a quorum is present. (approved 3/11/95)

ABOVE ARTICLE IV TO BE REPEALED AND REPLACED BY:

PROPOSED:

ARTICLE IV

Organization Staff

Section 1. The Board of Directors may employ a paid Executive Director or co-Executive Directors, who shall serve at the pleasure of the Board. The hiring and, if necessary, the firing of the Executive Director(s) must be approved by a two-thirds ($\frac{2}{3}$) vote of the Board.

Section 2. The Executive Director(s) shall be responsible for the day-to-day management of the organization and the museum, in compliance with the Constitution, these Bylaws, the policies and procedures and job descriptions approved by the Board, and the applicable law.

Section 3. The Board, in consultation with the Executive Director(s), shall approve the creation of and reorganization of the staff positions, and job descriptions for, any additional staff positions deemed necessary for the proper operation of the organization and the museum. The Executive Director(s) shall have the authority to hire and fire staff employees without the prior approval of the Board.

Section 4. The Board shall set the compensation for each staff position, including the Executive Director(s). The Board, in consultation with the Executive Director(s), shall review the compensation for each staff position at least once annually. The Board of Directors will perform an annual review of the Executive Director(s) prior to contract renewal or compensation review.



Research and Archives Committee Report



The current HCA Research and Archives Committee was constituted in July 2023 with three members: Mary Cameron, Eric Tankesley-Clarke and David Malick. The committee began meeting in August to create mission and vision statements to guide the work of the committee, as well as set long and short term goals and document issues requiring work and resolution.

Mission

The mission of the Research and Archives Committee is to preserve Heisey archives using professional archival processes and digitization in order to make the materials available to HCA membership, researchers and the general public to stimulate interest and research in Heisey glassware and its important place in the history of American hand-made glassware.

Vision

- Access to digitized materials will generally be determined by following the precedent set by A.H. Heisey & Co. Materials that were made public by Heisey (e.g. advertisements, brochures, patents, price lists, catalogs, etc.) should be made available to HCA membership and the general public via deployment to the HCA website.
- Non-public materials will be made available to researchers via an on-request process similar to what is described in the current HCA Archives Policy. Some of these materials may be deployed to HCA membership in the members-only area of the HCA website (e.g. turn books) as a benefit of membership.
- Digitization will be accomplished by a combination of flat-bed scanning and photography depending on the size and condition of the originals. Standards, equipment and personnel necessary to digitize the archives will be documented by the committee.
- The committee will determine storage, back-up and deployment processes in conjunction with HCA to preserve and enable access to digitized materials.
- Digitization and deployment processes will be executed in stages in order to realize immediate results and ensure that the work is actually started and eventually completed.
- When digitization is successfully completed, the need to access originals in the archive will be rare.



Accomplishments

- In November we completed documenting a high-level inventory of the materials in the archives to better understand the contents and enable access as needed until all materials are digitized. The detailed inventory will be completed in stages as materials are scanned.
- We created a scanning job aid to document best practices for flatbed scanning and arranged for the donation of a laptop computer and large format and standard format flatbed scanners to enable onsite scanning. This equipment has been delivered and set up in the archives office and includes the necessary software to scan items.
- We gathered and identified 34 rolls of microfilm and 143 sheets of microfiche of archive materials that were filmed by the Corning Glass Museum for HCA between 1984 and 1992. We obtained quotes to convert them to digital image files that can be converted to PDFs for deployment to the HCA website. A vendor was selected and the work is nearing completion. The materials contain 74 large format books, including turn books and cash ledgers as well as approximately 99 other publications and collections of documents.
- During two one-week working visits to the archives, we scanned nine boxes of original photographs as well as numerous advertisements, brochures, and other publications.



Future goals include sorting and identifying the original Heisey advertisements in a more logical chronological fashion; participating in the update of the HCA Archives Policy; and continuing scanning and deploying digitized materials to the HCA website once it has been migrated and updated.

Meet the Candidates

Bari Fauss

I bought my first piece of Heisey about 40 years ago. I grew up surrounded by Heisey because both my parents loved it, and they passed that love on to me. Some of my favorite childhood memories are of Mom and Dad finding a piece of Heisey while antiquing and their enthusiasm for collecting such beautiful glass. I started attending the annual convention with my mom back in the 1990s and I look back fondly on those days and wish she were still here to continue attending with me.

I have a BA in Art History from George Washington University. I have been a legal secretary for most of my career which is coming to an end April 30. I look forward to the next phase of my life as a retiree seeking meaningful, life fulfilling things to do, including travel and Heisey hunting.



I have been volunteering at the museum for about six years now, helping catalog auction glass and working during the spring and fall live auctions. Initially I ran for the Board in 2020 because I wanted to become more involved in shaping how the museum moves forward into the future, build the membership by introducing younger generations to the beautiful glass we all love and do whatever I can to make sure the museum (and the heritage it stands for) remains vibrant and strong. None of that has changed as I ask for your vote again in 2024. It is important, now more than ever before, as we seek to make sure the museum has the underpinnings and infrastructure to go the distance, beyond the life span of the current membership, that there be continuity and consensus on the Board.

Jay Goletz

Hello, just wanted to introduce myself to those new members who do not know me yet. I am running for my second consecutive term for the HCA board of directors. I have lived in Newark for almost 35 years where I met my lovely wife, Julie, who is also an HCA member. We have both been members for over 11 years, and members of the Buckeye Heisey Collectors Club. As far as being interested in glass, I believe I must have got it from my mom who was a collector of various pieces of Fenton, Fostoria, Imperial Glass and others, especially carnival glass. I was always fascinated by how it shines once it is polished. I must thank Michael Maher for getting me started in this great hobby and organization. This organization is only as good as its members, and I firmly believe we have the best around. I really enjoy



Candidate Jay Goletz continued

seeing this group kick in and volunteer to help with certain activities and we need more of this! There are a bunch of committees that anybody can help on, and you don't have to be local to join. I am chairperson of the Properties Committee and sit on the Warehouse Committee and have seen a lot of successes over the past couple of years, from painting the exterior of the buildings, fix the walkway, new fountain, and getting the new security cameras installed (finally!) just to name a few. I believe that the Board has done a lot, but I know that we can do more with your help. My goals are to help Heisey grow in the neighborhood and to assist with getting more of the youth interested in HCA to grow our ranks. More importantly, however, my goal as a board member is to keep bringing your interests to the rest of the HCA organization. We need to be more open with each other and help cancel this negativity and division. I urge you to reach out specifically to a certain board member or president with advice and recommendations. We all need to work together. Thank you.

David Malick

I have been a glass collector for over 30 years. I joined HCA and the Heisey Collectors Club of MI 14 years ago. During that time, I have volunteered to produce several books as fund raisers for HCA including:

- Heisey Design Patents
- Heisey Invention Patents
- Table Glass and How to Use It: A Handbook for the Hostess
- Choosing Your Crystal Pattern
- Gifts of Glassware
- Encyclopedia of Heisey Advertising - Volume I: Newspaper Advertising
- Encyclopedia of Heisey Advertising - Volume II: Advertising to the Public
- Table Talk



In addition, I produced the reprint of the Heisey Candlesticks Candelabra and Lamps book as well as the first printing of the Encyclopedia of Heisey Glassware Volume II-Cuttings and Engravings. Some of these projects involved direct reprints of existing materials and others involved the research and assembly of materials into a coherent whole.

I serve as secretary of the HCC of MI and the chair of the HCA Research and Archives committee.

As Heisey collectors, we are fortunate that Heisey glassware is one of the most well documented American art forms available. I think that providing context and background about what we collect is key to attracting new collectors and members. I believe that HCA should make the preservation of its archives and the sharing of that material with its membership and the general public a high priority. The Research and Archives committee has begun to make progress in this area as it touches on so many other areas such as education and ultimately makes Heisey glassware relevant to a wider audience of potential collectors. As a board member, I will continue to work toward this goal and encourage a more open and constructive relationship between the board and members at large.

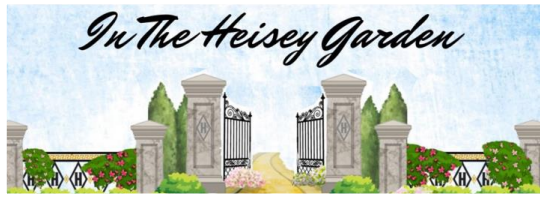

Heisey Collectors of America Convention

June 13-15, 2024

Schedule of Events

Events marked with an asterisk () are paid events and pre-registration is necessary for admission.

Tickets are not available at the door.

Thursday, June 13

Registration: 10 a.m.- 4 p.m. Location: Museum Multipurpose Room

Glass Show and Sale and Table Displays Premiere: 4 p.m. - 7 p.m.

Location: The Skylight, 85 E. Main Street, Newark, Ohio

Silent Auction Opens: Bidding opens June 13. Bidding ends Friday June 14 at 3 p.m.

Location: Items displayed in museum galleries 1 & 2

***Garden Party at the Museum, 7:30 p.m. - 9 p.m.**

Meet the HCA Board candidates

Hors d'oeuvres

Ask the Experts- "Is it Heisey?" Bring your mystery piece for our experts.

In the Heisey Garden Scavenger Hunt – prizes will be awarded

Friday, June 14

SPECIAL MUSEUM HOURS: 9 A.M. - 3 P.M.

Registration continues: 9 a.m. - 3 p.m. Location: Museum Multipurpose Room

Silent Auction continues until 3 p.m.

Location: Items displayed in museum galleries 1 & 2

Light continental breakfast 9 a.m. (donations appreciated)

Membership meeting and study club reports: 9:30 a.m.- noon.

Membership election: 9:35 a.m. to 10 a.m.

Glass Show and Sale: noon - 4 p.m.

Table setting displays "Showcase": 1 p.m. - 1:45 p.m.

Silent Auction ends and Museum closes at 3:00 p.m.

Show closes 4 p.m.

***In The Heisey Garden Banquet at the Doubletree by Hilton, 50 N Second St.**

5:30 p.m. Cash bar

6:30 p.m. Dinner

7:30 p.m. Live Auction.

Saturday, June 15

Canal Market Glass Flea Market and Dime Toss 8 a.m. - noon

Location: Canal Market District, 28 East Canal Street

Glass Show and Sale & Table Setting Displays: 11 a.m. - 3 p.m.

Location: The Skylight, 85 E. Main Street, Newark, Ohio

In The Heisey Garden



Heisey Collectors of America Convention - June 13-15, 2024 REGISTRATION FORM (Registration ends May 29)

Registration is required for all attendees. An individual form must be completed per registrant.

Name _____ Are you under the age of 18? Over 18?

Address _____

City _____ State _____ Zip _____

Phone _____ Email _____

Are you on: Facebook: Instagram: X (formerly Twitter): Pinterest:

	<u>Cost per person</u>	<u># of attendees</u>	<u>SUBTOTAL</u>
Convention Registration Fee	\$30	x _____	= _____

Convention registration includes: Heisey Glass Show & Sale, Premier Night Preview, Glass Show displays, seminars, Heisey Museum hospitality room, and silent auction. Registration fee will be waived for those under 18 years of age.

Advance registration and additional fee is required for the following events:

Night at the Museum	\$30	x _____	= _____
Thursday, June 13, 7:30-9 p.m. Appetizers and Desserts National Heisey Glass Museum			

HCA Annual Banquet			
Friday, June 14, 5:30 p.m. Reception, 6:30 p.m. Dinner and Program Doubletree by Hilton			

Individual Ticket	\$50	x _____	= _____
-------------------	------	---------	---------

Individual Ticket (Guests Under 12 years old)	\$20	x _____	= _____
---	------	---------	---------

TOTAL REGISTRATION
AMOUNT DUE: _____

Banquet Entrée (Circle 1)

Herb Roasted Pork Loin

Roasted Salmon

Ricotta Stuffed Shells

Payment Details:

Cash Check Mastercard Visa Discover

Card # _____ EXP _____ CVV _____

Mail: Send form with payment to: Convention Registration, National Heisey Glass Museum
169 W. Church Street, Newark, Ohio 43055

Online: complete form and pay online at www.Heiseymuseum.org

Phone: Call 740-345-2932 with your registration and payment **FAX** forms to: 740-345-9638

In-person: Bring your form and payment to the Heisey Museum



HEISEY AUCTION NEWS



Hello Heisey Auction fans!

HCA and the auction team had another spectacular Spring Benefit Auction last month!

I don't have the final figures yet, but they are on track to make budget.

We had a "new" beginning to the SBA this year - the reproductions only auction! This auction did really well and raised much needed funds for the replacement of the heating and air conditioning units. We are looking into doing it again in 2025.

The 2024 Dave Spahr Fall Select auction preparation is in full swing. Those of you who have submitted a list of glass to be considered should be getting the finalized list of what glass to send very soon. I've seen some really nice glass lists so this should be a really nice auction. Bid high and bid often!

Going forward from the last auction, the auction team will be unable to provide in-house winning bidders boxes or wrap due to the escalating costs. If you are coming to the auction, please bring your own boxes and wrap. Boxes and wrap are available at local hardware stores or your local Walmart.

The auction team is still looking for members who are downsizing estates or just thinning their collection to consign their glass for future auctions. We are looking for any size collection, from just a few items to large collections. Please contact me for details.

Roy Eggert
Auction Chair
Auction Firm Manager



HEISEY HISTORICAL AS: Ladies' Home Journal, McCall's, December 1911



HEISEY'S
TRADE MARK
GLASSWARE

Useful - Sensible - Attractive **HEISEY'S GLASSWARE**

aids you in making your table attractive both for family and guests. **HEISEY'S GLASSWARE** is clearer in color, better in finish and more durable than ordinary glassware and costs but little more. It affords a profusion of beautiful, sensible articles to choose from for the table, living-room, boudoir and den.

Our art booklet "Table Glass and How to Use It" is valuable to the home-maker and hostess. It contains many helpful suggestions on effective table arrangement, lighting, decorations, correct serving, etc., and illustrates appropriate articles of **HEISEY'S GLASSWARE**. We shall be glad to send a copy to your address on request.

A. H. HEISEY & CO., Newark, Ohio, U. S. A.

NEW! Heisey Candlesticks, Candelabra and Lamps

Revised and Expanded Edition

AVAILABLE FOR PREORDERING - MUSEUM DELIVERY EXPECTED BY JUNE 15

Heisey Candlesticks, Candelabra, and Lamps comes out soon in a brand-new, revised and expanded third edition; a pre-order form is available at the bottom of this page. More than just a reprint, the third edition has the same look and feel of the previous editions and most of the excellent content from them remains intact. Now I hear you asking, "If that's the case, what's *really* new about this edition?"

The third edition adds around 30 items, most of them never before published anywhere. This includes not only the titular candlesticks, candelabra and lamps, but also bobeches, prisms, epergnettes and other parts. In addition, variations of well-known pieces make their first appearances in the book. Certain other items that were mentioned previously only in passing are now included with their own full-scale entries. This is especially true for several lamps. Nearly 50 new images are included in the new book, including drawings from the archives never published until now.

What about revisions? It was 1984 when Tom Felt, Bob O'Grady, and Jack Metcalf concluded their stellar work on the first edition. The result, with its scholarship and clarity, set a high standard among glass reference books. Forty years have passed, however, and new information has been uncovered. Most significantly, Imperial closed during that time. Original Heisey factory documentation came to the museum archives that was not available to Tom Felt when he did his

initial research. The upside to that is my own research led to the thrill of discovery with gratifying frequency—a fancy way of saying I was excited to find a lot of new things. In the meantime, longtime Heisey admirers came forward with tantalizing tips and stories that yielded book-worthy finds. Even Tom Felt himself offered a trove of images, several of which found their way into the new edition.

With all that in hand, over the past year I reviewed the entire candlestick book from front to back, page by page, line by line, updating and adding information as I went. Time constraints and technical hurdles, those twin beasts of nearly every project, menaced progress, but they were overcome in the end, thanks to the support of the Education Committee and the museum. There are many individuals who should be acknowledged, and I have mentioned them in the foreword to the third edition. I guess if you want to know who they are, you'll just have to buy the book.

- Eric Tankesley-Clarke

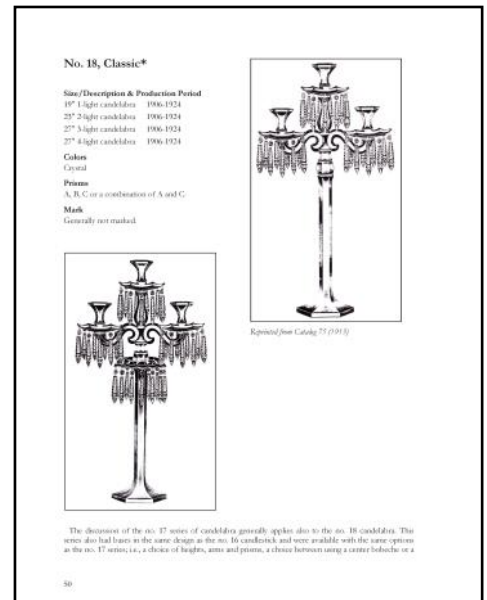

Page 50: the No. 18 Classic

"The third edition adds around 30 items, most of them never before published anywhere."

Mail pre-order with payment and form below or call: 740-345-2932

Name _____
 Address _____
 City _____ State _____ Zip _____
 Phone & Email _____

ORDER DETAILS: Heisey Candlesticks, Candelabra and Lamps

Quantity _____ X Price per Book (**\$35.00 per book**)
 Specify: Pick Up _____ (date) _____ or Ship _____ (**\$8.00 shipping & handling**)
TOTAL: \$ _____ (Ohio residents please include tax - 7.25%)

Check# _____ Select Credit Card: Visa _____ MasterCard _____ Discover _____
 Card# _____ Exp. Date _____ Security Code _____

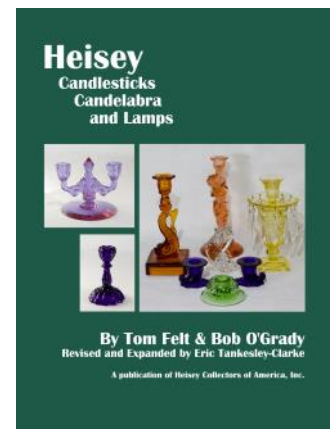



In Fond Memory

Donald Lee Ensor passed away in his home on the morning of April 10th, 2024. He attended Louisville Deaf School, Westport High School, and Murray State University.

He served as a regional director for the Oral Deaf Adult Section of the Alexander Graham Bell Association for the Deaf from 1982 to 1986, served as a member of the Kentucky Department of Education's Bureau of Rehabilitation Services State Advisory Committee on Deafness, and was a founding member of the Lincoln Foundation of Washington County, Kentucky. He was ordained a deacon of the DeHaven Memorial Baptist Church in La Grange, Kentucky.

Donald was a caring friend, a wonderful husband, and a loving father. He had many hobbies, in particular his passion for Heisey glass, which he shared with his devoted wife Vicki.

He was also very proud to be a distant cousin of Abraham Lincoln.

Donald is survived by his wife of 55 years, Vicki Seelig Ensor; his son, George Benjamin Ensor and George's wife, Lanie Hopping; and his cat, Spot.

Memorial gifts should be made to the Heuser Learning Academy, and the Campbellsville University Bridge to Success Program.



On April 3, 2024, **Hope Heisey Jeffrey ("Hobby")**, of South Dartmouth, Massachusetts (formerly of Tenafly, New Jersey), passed away peacefully at the age of 80 with her husband, children, and brother by her side. A loving and devoted mother, wife, sister, and friend, Hobby was kind-hearted and caring and will be fondly remembered for her radiant smile and ability to make others feel welcome.

Hobby was born on June 9, 1943, in Columbus, Ohio and grew up in Granville, Ohio. The second of four children, she graduated with honors from Granville High School, she married the love of her life, David Jeffrey, at St. Luke's Episcopal Church in Granville.

Hobby led an active life, full of art, family, friends, and travel. She loved the outdoors and especially cherished her time in Captiva, Florida, where she and David spent the winter months. She and David loved foreign travel.

Hobby is predeceased by her parents, Augustus II and Susan Heisey; sisters, Susan Been and Justina Heisey, and her son, Patrick A. Jeffrey. She is survived by her husband of more than 60 years, David L.K. Jeffrey; brother, Augustus Heisey III, of Tybee Island, GA; children, grandchildren and many nieces and nephews.



If you know of a HCA member who has passed away, please forward all pertinent information to: membership@heiseymuseum.org. Thank you.

Heisey historical ad from House Beautiful magazine
February 1950, May 1951

Plantation
**fine crystal
for a festive table**

Brilliant as the tropical sun . . . this hand-wrought Heisey pattern has plucked an exotic pineapple for its modern motif. Dramatic for company occasions, yet Plantation stemware and table accessories are modestly priced for your family's everyday use or for welcome gifts. A. H. Heisey & Co., Dept. H-3 Newark, Ohio. Write for new Plantation booklet.

Heisey
HAND-WROUGHT CRYSTAL

THE FINEST IN GLASSWARE, MADE IN AMERICA BY HAND

Sarah Carlisle - 317-605-7068

Joey Cogdill - 864-979-8963

Michael Maher - 740-644-1796

Bill McKelvey - 419-564-5256

Pontil & Still LLC 740-877-0064

HEISEY Glass Show & Sale

Friday, June 14 - 12pm-6pm
Saturday, June 15 - 10am - 2pm

**FREE
ADMISSION**

BRING YOUR VOGEL HEISEY RESEARCH BOOKS TO
BE SIGNED BY DURWARD VOGEL, DESCENDANT OF
THE ORIGINAL HEISEY RESEARCHER

GMP Union Hall
350 Hudson Avenue
Newark, Ohio 43055

SHOW DEALERS BUY HEISEY GLASSWARE!

f Find & follow us on Facebook!

Contact us for questions or details

PAID ADVERTISEMENT

23rd ANNUAL TENNESSEE ELEGANT AND DEPRESSION GLASS SHOW AND SALE JULY 20 - 21, 2024

*** *NEW LOCATION* ***
GALLATIN CIVIC CENTER
210 E. ALBERT GALLATIN AVENUE
GALLATIN, TN 37066

SAT / JULY 20 HOURS - 10 AM TO 5 PM
with Guest Speaker at 1 PM

SUN / JULY 21 HOURS - 11 AM TO 3 PM

\$8.00 ADMISSION – GOOD FOR BOTH DAYS
Plenty of CONVENIENT FREE PARKING!!

*FEATURING VINTAGE GLASSWARE
ELEGANT, MID-CENTURY & DEPRESSION ERA
DEALERS FROM ACROSS THE COUNTRY*

HOSTED BY FOSTORIA GLASS SOCIETY OF TENNESSEE
FOR SHOW INFORMATION AND UPDATES:
Website: www.fostoria-tennessee.com
Social Media: www.facebook.com/fostoriaglass.tn
Paid Advertisement

DICK MARSH MEMORIAL CAR SHOW

The most
popular
show in
town!

\$10.00
REGISTRATION

Sunday
July 28

REGISTRATION
11AM-3PM

NATIONAL HEISEY
GLASS MUSEUM
169 WEST CHURCH
STREET - NEWARK



**TOP 40 AWARDS - DASH PLAQUES - DOOR PRIZES -
50/50 - FOOD TRUCK - ICE CREAM - MUSIC - FUN**
HOSTED BY THE BUCKEYE HEISEY COLLECTORS CLUB WITH JAMES MATHENY
- PROCEEDS BENEFIT THE NATIONAL HEISEY GLASS MUSEUM -



HOSTED IN MEMORY OF DICK MARSH AND JIM MATHENY!



Heisey in the Museum Shop



The listed items on this page are available in the museum shop and would make wonderful gifts.

HCA members have exclusive access to these items from 11 a.m. ET on Wednesday, May 15, through close of business on Wednesday, May 29.

Call the shop (740-345-2932) if you are interested in purchasing any of these items.

Member discount does not apply during this special time period.

On Thursday, May 30 they become available for sale to the public.

Item No.	Pattern No.	Item Name / Description—"H" denotes piece is marked with Diamond H	Price
1	2	Old Williamsburg cstk 11" pr	\$95 pr
2	30	Tom Thumb cstk toy, pr (2)	\$25 pr
3	33	Skirted Panel cstk toy, pr H	\$22 pr
4	112	Mercury cstk w/507 Orchid etch, pr	\$25 pr
5	160	Locket on Chain punch cup	\$18
6	335	Prince of Wales table cr/sugar/lid H	\$45 set
7	419	Sussex finger bowl Moongleam H	\$20
8	433	Greek Key cr/sugar hotel oval H	\$40 set
9	433	Greek Key plate 4" and 6" both with metal frames H	\$22 ea
10	1201	Fandango sugar shaker - no lid	\$36
11	1404	Old Sandwich creamer Sahara H	\$22
12	1424	Lucky Strike ashtray H	\$25
13	1469	Ridgeleigh star relish, 5 pt H	\$22
14	1469	Ridgeleigh vase 8" H (2)	\$40 ea
15	1495	Fern mayo/underplate w/507 Orchid etch	\$48 set
16	1506	Provincial cr/sugar/tray ind H	\$26 set
17	1519	Waverly cr/sugar/tray ind w/507 Orchid etch H	\$36 set
18	1519	Waverly violet vase w/507 Orchid etch H	\$36
19	1590	Zodiac nappy 4" H (2)	\$12 ea
20	1632	Lodestar nappy shallow, 8" Dawn H	\$60

There is someone in the museum shop during the museum's hours of operation to help answer questions or take orders. When ordering by phone, please have a credit card ready. **In the event of payment issues, ordered items will go back into inventory after seven business days.** When ordering by mail, please be sure to allow for shipping charges and sales tax. Call the museum for tax and shipping cost estimates. Please note that the HCA member discount does not apply to special project items.

All shipping is done through USPS. Packages are not insured. If you have not received a package or it arrives damaged, please call the museum. We can assist you in tracking your packages.

If you would like to make a glass donation to the museum or have questions regarding items on loan, contact the museum at 740-345-2932. HCA reserves the right to accept or refuse items based on current holdings.

In The Heisey Garden



ANNUAL GLASS SHOW AND SALE

and Table Setting Displays

OPENING NIGHT PREMIERE: THURSDAY, JUNE 13, 4-7 P.M.

\$20 premiere entry good for both days (CONVENTION REGISTRANTS AND THOSE 12 OR YOUNGER ARE FREE)

FRIDAY, JUNE 14, 12-4 P.M.

\$5 ADMISSION

SATURDAY, JUNE 15, 11 A.M.-3 P.M.

FREE ADMISSION

LOCATION: THE SKYLIGHT 85 E. MAIN STREET, NEWARK, OHIO 43055

FOR MORE INFORMATION, CALL: 740-345-2932 OR VISIT OUR WEBSITE AT: HEISEYMUSEUM.ORG

Glass Show!

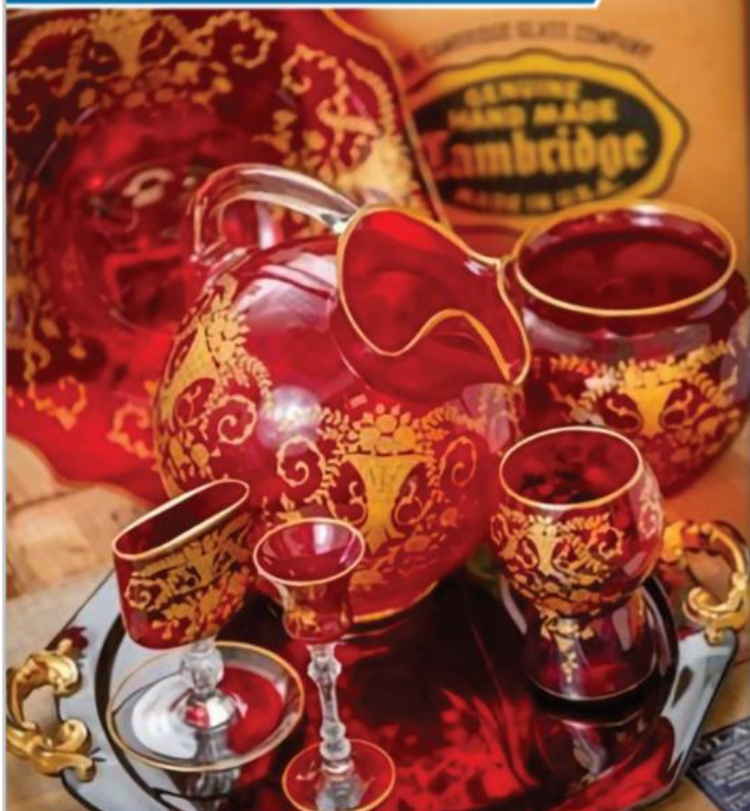

**Sponsored by the National
Cambridge Collectors**



Cambridge



& More!

NCC Glass Show & Sale

June 28-29, 2024

Fri 1-5pm / Sat 10:30-4pm \$5

Pritchard-Laughlin Civic Center

7033 Glenn Highway; Cambridge OH

Glass Dash

June 29, 2024

7-8:30am early bird \$10 / 8:30-11am \$5

St. Benedict's Gymnasium

701 Steubenville Ave; Cambridge OH

CambridgeGlass.org

PAID ADVERTISING

New and Returning Members March



Tristyn Swanson	Kansas
Joshua Swanson	Kansas
Ian Baker	Kansas
Michael Dunlap	Texas
Trina McGinnis	Michigan
Bruce and Trish Frey	Ohio
Margaret Johnson	Minnesota
Douglas Ingraham	Minnesota

HCA Membership Numbers

This Month: 951

Last Month: 944

Members who have not renewed to date
are not included in this number.

The total changes monthly.



Museum Volunteers March



David Blair
Bob and Pat Day
Howard Long
Walter Ludwig
Richard Nicholson
Karen O'Hare
Dick and Marilyn Smith

Thank You!



New Heisey History Articles Needed!

To promote a more robust offering of educational materials in the newsletter, the editors are seeking articles for publication. Members are encouraged to submit articles on topics of history, patterns, cuttings, etchings, manufacturing techniques, etc. HCA's members are the true experts on Heisey glass and have a long history of sharing their expertise with other members through articles they write for *Heisey News*. Deadlines for submission of articles are the 7th day of the month. The newsletter editor will keep contributors informed about the planned publication of their articles.

Please make all submissions to newsletter@heiseymuseum.org.

Note: HCA reserves the right to edit the articles for style and grammar. All articles that are submitted become the property of Heisey Collectors of America.

Heisey Study Club Directory



#7: DAYTON AREA HEISEY COLLECTORS CLUB

(daytonheiseyclub.org) Serving southwest Ohio, northern Kentucky, and eastern Indiana. Meets virtually the 3rd Tuesday of the month September thru May (no December meeting) For meeting details contact: Cheryl Hoskins, President 757-784-0875 Doho_100@yahoo.com www.daytonheiseyclub.org

#13: HEISEY CLUB OF CALIFORNIA (www.heiseyclubca.org)

Serving Southern California (San Diego to Santa Barbara). Meets 4th Sunday at 12:30 p.m. except November, and 2nd Sunday in December in members' homes throughout region. Contact: David Blair Email: glassguy1@yahoo.com.

#15: HEISEY COLLECTORS CLUB OF MICHIGAN

Serving Michigan and northern Indiana. Meets six times per year in members' homes throughout the region. Please contact Rick Van Meer at 517-782-3874 rickvanmeer@comcast.net

#16: HEISEY COLLECTORS OF TEXAS

(www.heiseycollectorsoftexas.org) Serving Texas. Meets odd numbered months 2nd Saturday at 1 p.m. Meeting locations to be announced. Contact Mike Morgan at 281-433-4551. Email: mbmorgan1965@gmail.com

#20: BUCKEYE HEISEY COLLECTORS CLUB

Serving Ohio. Meets 4th Monday September through May in Heisey Museum Meeting Room or members' homes. Bring your latest Heisey 'finds' to share. Please contact Jay Goletz (740) 345-9307 Email: goletzjr@gmail.com

#22: NORTHWEST HEISEY COLLECTORS CLUB

Serving Washington (west of Cascade Mountains; north to Canadian border; south to Oregon). Meets 1st Saturday at noon with potluck in members' homes. Contact Deborah de Jong at 425-868-0457 bahama50@hotmail.com

#38: NORTH CAROLINA HEISEY STUDY GROUP

(www.northcarolinaheiseystudygroup.org) Serving North Carolina, South Carolina, Virginia (also have members from West Virginia and Texas). Meets odd numbered months 2nd Saturday at noon at Replacements, LTD in Greensboro, NC. Contact: Jaime Robinson by email jaime.robinson@replacements.com

#49: GREAT PLAINS HEISEY CLUB

(www.greatplainsheiseyclub.org) Serving west of Mississippi, east of Rocky Mountains. Meets March, May, July, September and November in members' homes throughout region. Specific dates and times to be announced. Contact Kathy Files at 816-468-7087. Email: tkfiles@kc.rr.com

#50: NORTHWOODS HEISEY STUDY CLUB

Serving Minnesota and Wisconsin. Meets March, May, August, and October in members' homes throughout region. Specific dates and times to be announced. Contact Doug Olson at 651-343-0430 Email: dmolson555@gmail.com

#51: NORTHEAST FLORIDA HEISEY STUDY CLUB

Serving northeast Florida, meets 3 times a year at the Avonlea Antique Mall's Olde Florida Café, Jacksonville, FL. Call for specific dates. Contact: Chuck Carroll email jaxcat8@yahoo.com

#52: NORTHERN VIRGINIA HEISEY STUDY CLUB

Serving Northern Virginia to include Maryland and Washington D.C. Meets September thru May. Please email for date and location each month. Contact Elizabeth Shirley by email at esshirley@msn.com.

#53: KENTUCKY HEISEY COLLECTORS GROUP

Our group is sharing Heisey knowledge & having fun. Please RSVP so we have enough chairs. Contact Doug Meister 502-266-7971 or revdrdoug92@gmail.com for more information!

#54: HOOSIER HEISEY STUDY CLUB

Having fun sharing Heisey glass and ideas, if you are in Indianapolis or anywhere nearby you are welcome. The group is looking forward to its next meeting. For time and directions contact geoff.c.heisey@gmail.com or call 317-250-5295

#55 - THE CRYSTAL CLEAR VIRTUAL HEISEY STUDY CLUB

Provides an online platform for HCA members from across the globe to meet, learn more about Heisey and support the Museum. Meetings are held online at 7 pm ET on the 2nd Wednesday of each month. Want to learn more? Visit us on Facebook or contact Michael Maher at 740-644-1796 or CCVHSC@yahoo.com.



Membership Renewal: Check above your name on the mailing label of your Heisey News for your membership expiration date. If it is the current month, make sure your dues are paid soon to receive next month's issue of *Heisey News*. Feel free to use the handy form below.

MEMBERSHIP APPLICATION

Name _____

Address _____

City/State/Zip _____

Phone _____

E-Mail _____

Additional Member _____

MEMBERSHIP LEVELS

Membership dues (except the one-time voting fee) must be renewed yearly. Please indicate number of persons joining.

- Associate Member** (one person) **\$40**
 Additional Household Member **\$10 each**
(list names at bottom of form)
 Voting Member (one-time fee) **\$25 each**
One-time fee entitles you to voting privileges in HCA.

ENDOWMENT MEMBERSHIP

Join as an Endowment Member and increase your support of HCA. Each level includes Associate dues (\$40.00 plus \$10.00 for each additional household member). The remainder goes into the Endowment Fund to build a strong future for the National Heisey Glass Museum.

- Individual Contributing** (one person) **\$60**
 Joint Contributing (two people) **\$70**
 Family Contributing **\$85**
(parents and children under 18)
 Patron **\$150**
 Sponsor **\$300**
 Benefactor **\$500**

SHIPPING & HANDLING FEES FOR OUTSIDE US

Additional shipping charges are required for members living outside the U.S. Current rates for Canada are \$30; for other countries, contact the museum. These rates are subject to change at any time due to rate changes made by the US Postal Service. To verify current rates, call (740) 345-2932 or e-mail membership@HeiseyMuseum.org.

Amount Enclosed _____

Payment: Check MasterCard Visa Discover
(Make check payable to: Heisey Collectors of America, Inc.)

Card # _____

Exp. Date _____ Security Code _____

Additional Household Member (s) _____

HCA may share my contact information with Heisey study clubs: Yes No

ADVERTISING GUIDELINES

- The content of an advertisement is the responsibility of the advertiser. Advertisers will be given an opportunity to approve a final proof of their ad. *Heisey News* is not responsible for errors in an advertisement that has received final approval from the advertiser.
- All paid advertisements must be clearly labeled *Paid Advertisement* in a 12-point or larger font.
- HCA reserves the right to decline an advertisement for any reason.
- Advertisements containing reproductions or reissues will not knowingly be accepted unless they are clearly identified, e.g. Heisey by Imperial.
- Ad copy must be received by the first of the month before publication.
- Print-ready art files should be in PDF or JPEG formats.
- For the best possible reproduction, email your ad to business@HeiseyMuseum.org.
- Mailed ads must be supplied to size and ready to scan. Mail to HCA Advertising, 169 W. Church Street, Newark Ohio 43055.
- Include payment: type of credit card, account number and expiration date.
- Each study club chartered by HCA is eligible to receive one free half-page advertisement, in color or black and white, each calendar year.

CLASSIFIED

20 cents per word for members; 30 cents per word for non-members; \$5 minimum for ads less than 1/8 page. Personal ads 1/8 page limit. Abbreviations and initials count as words.

DISPLAY

1/8 page: Member \$20 Non-member \$30
1/4 page: Member \$40 Non-member \$60
1/2 page: Member \$80 Non-member \$120
Full page: Member \$160 Non-member \$240
Color: Additional \$25 (member), \$30 (non-member)

DEALER DIRECTORY PAGE and WEBSITE

Standard ad \$48 per year

SUBMISSION GUIDELINES

Send articles for publication in *HEISEY NEWS* to Kirk Homrighouse, newsletter@HeiseyMuseum.org. We will acknowledge receipt of your submission, and will advise you if, for some reason, we are not able to publish it that month. We reserve the right to edit. **New submission deadline is the 7th of the month preceding the month of publication. (For example, the deadline for the February issue is Jan. 7.)**

The opinions expressed in articles in *HEISEY NEWS* are those of their authors and do not necessarily reflect the views of HCA. The editorial staff reserves the right to edit submissions, with or without author consent, and to refuse material submitted for publication.

Heisey Dealer Directory



REALMS IN GLASS

Roy Eggert
Heisey • Custom Stained Glass
9423 Saddlebrook Court
Frederick, MD 21701
240-361-8146 • royegg54@comcast.net

THE FLYING MAHER

Michael Maher
Servicing the Licking County area
Paying Cash for Heisey Glass
Heath, Ohio 43056
740-644-1796
TheFlyingMaher@yahoo.com

MOONGLEAM ANTIQUES

Heisey Glassware & American Art Pottery
John Woytowicz
70 Pleasant St., Gardiner, ME 04345
207-592-0692
hawthorn57@gmail.com

ALL HEISEY AUCTION

Consignments Welcome
Apple Tree Auction Center
1625 W. Church Street
Newark, OH 43055 • 740-344-4282

HEISEY HUNTERS

William McKelvey
BUY and SELL
SHOWS and SHIP
Phone: 419-564-5256

CRYSTAL LADY

1817 Vinton Street, Omaha, NE 68108
Bill & Joann Hagerty &
Marcie Hagerty Bergquist
402-699-0422
Specializing in Elegant Glass & Collectibles
www.crystalladyantiques.com

MATILDA CHARLOTTE ANTIQUES, ETC.

Buy and Selling Heisey
Online at
auctionohio.com/affiliates
If possible, please email pictures of items for
sale to: mcantiquesetc@yahoo.com

MOUNDBUILDERS SECOND GENERATION

Barbara & Richard Bartlett
Heisey Exclusively! 904-280-0450
PO Box 1931, Ponte Vedra Beach, FL 32082
Cell: 740-835-6939
CLASYGLAS2@AOL.COM

DICK & MARILYN SMITH

HEISEY Glass - Buy - Appraisals
Shows - Mail Orders - Booth T63
Anthony Drive Antique Mall
NEWARK, OH 43055
740-258-3512 / HCA MEMBER
prestonmom225@yahoo.com

HCA AUCTIONS

We accept large consignments from
members downsizing their collections.
Go to: www.HeiseyMuseum.org
Under "auctions" for "accepting member
glass collections" for more details

The AMERICAN BELL ASSOCIATION INTERNATIONAL, Inc.

7210 Bellbrook Drive
San Antonio, TX 78227

HCA AUCTIONS

We accept large consignments from
members downsizing their collections.
Go to: www.HeiseyMuseum.org
Under "auctions" for "accepting member
glass collections" for more details

OLD COLONY PUBLICATIONS

Specializing in new and reprinted books
about American glass, including Heisey,
Fostoria and Cambridge.
www.lulu.com/spotlight/oldcolonypub



**ADVERTISE YOUR
BUSINESS
IN THIS SPACE
FOR ONLY \$48.00 PER YEAR**

HCA

Heisey Collectors of America

CALL FOR HCA VOLUNTEERS!

Our dedicated Heisey volunteers are of critical importance to keeping our museum, auctions and events running smoothly. We are currently seeking new volunteers to offer their time and talents to the organization that we all love so much. No effort is too small and will be greatly appreciated!

If interested, please contact us at:

(740) 345-2932 or email us at:

Membership@Heiseymuseum.org



MAY 2024

HEISEY NEWS is published and printed monthly by Heisey Collectors of America, Inc. (HCA). Subscription is limited to HCA members. First class mailing is available for an extra \$50, due with payment of membership. If you are having difficulty receiving your newsletter, please contact the HCA Administrative Office Tuesday through Friday, 10 a.m. to 4 p.m. (subject to change). Back issues are available from files for \$3 per issue plus shipping and handling.



Periodical Postage
Paid at the Post Office
In Newark, OH 43055
Publication #00986
POSTMASTER SEND FORM TO:
HCA
169 W. Church Street
Newark, Ohio 43055

TO:

Come at your leisure to enjoy more than 9,000 pieces of glassware produced by A.H. Heisey and Company from 1896-1957. Hundreds of patterns are featured in all production colors. Rare and experimental items are included as well. Facilities are air-conditioned and handicapped accessible.

HNMAY2024

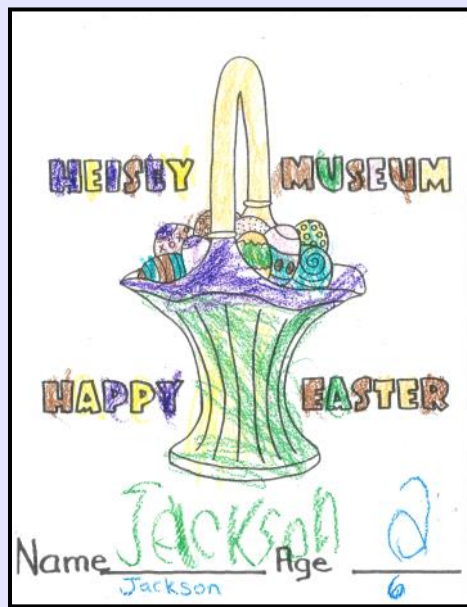
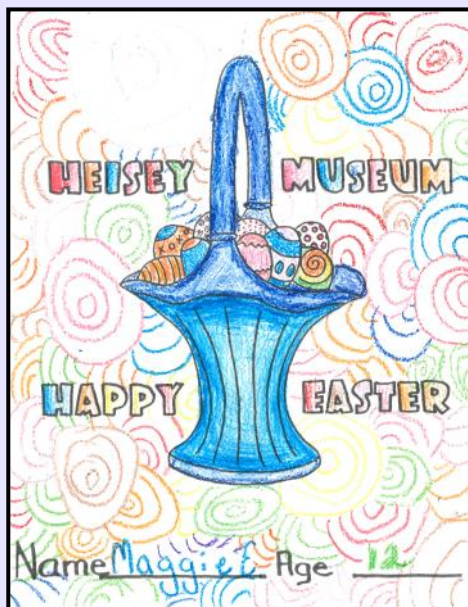
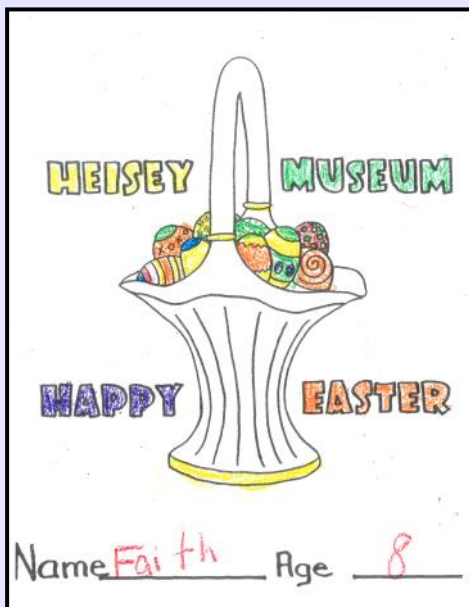

2024 Heisey Easter Egg Hunt Winners

One of our favorite events during the Heisey Easter Egg Hunt is the annual coloring contest. This year we had an exceptional group of skillful young artists which made choosing the winners very difficult.

Congratulations to Faith, Maggie and Jackson for their beautiful work!