

HEISEY NEWS

The Official Publication of Heisey Collectors of America, Inc.

Volume XXXVIII No. 10

October 2009

ISSN 0731-8014

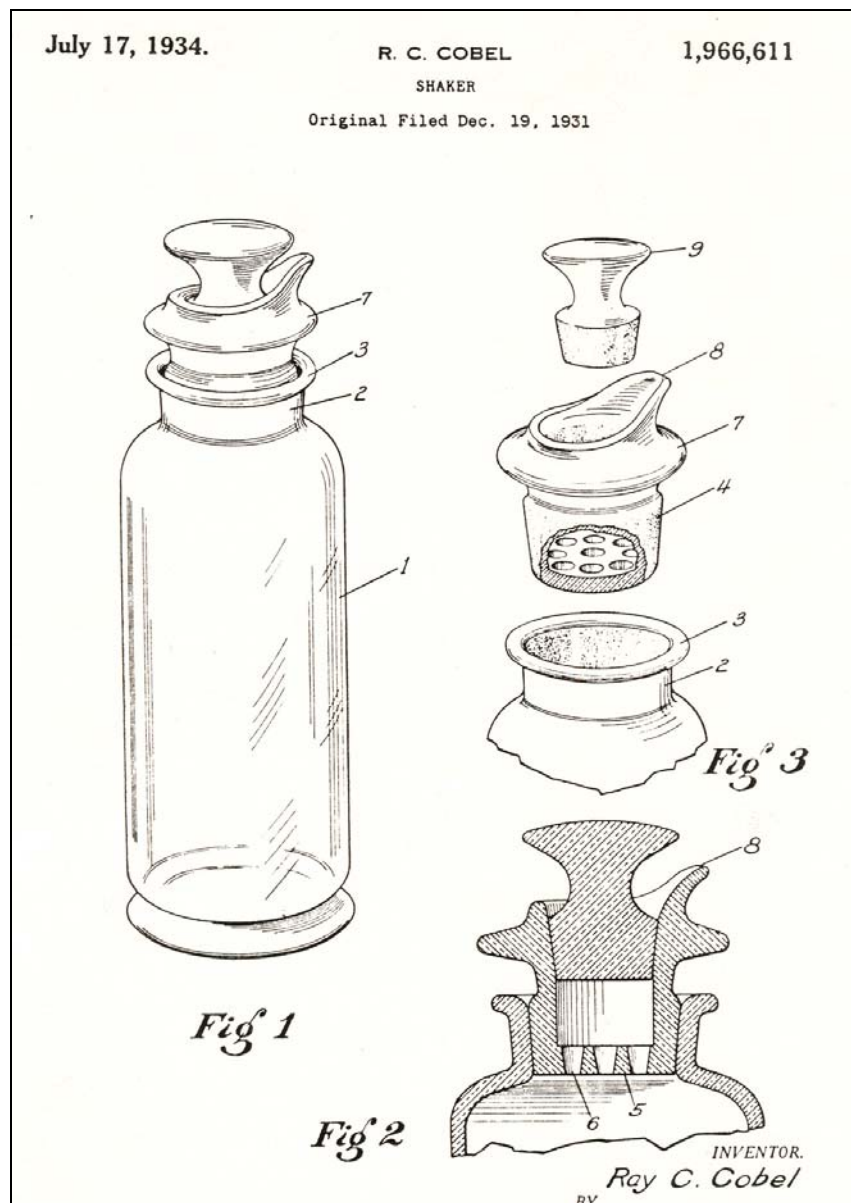

Patent 1,966,611 – 4225 Cobel Cocktail Shaker

Read Part Eight of the Story of A. H. Heisey & Company Utility Patents on Page 5

HEISEY NEWS

Heisey Collectors of America, Inc.

169 West Church Street

Newark, Ohio 43055

Phone 740-345-2932 Fax 740-345-9638

Web Site: www.heiseyMuseum.org

All Rights Reserved 2009

ISSN 0731-8014

Staff and Phone Extensions

Curator, Walter Ludwig, curator@heiseyMuseum.org, Ext. 4

Clerks, Justin Church, Ashley Selby, Micki Wareham

membership@heiseyMuseum.org, Ext. 1

Gift Shop, Ext. 5

HCA Board of Directors:

President, Sue Kilgore – Kalamazoo, MI, 269-345-3990 –

hcapresident@heiseyMuseum.org

Vice-President, Karen Taylo – New Bern, NC, 252-637-9985

Secretary, Charlene Bowman – Clarksville, OH, 937-289-2114

Treasurer, Sharon Orienter – Rochester, NY, 585-288-8076

Member-at-Large, Dave Spahr - Xenia, OH, 937-372-7166

Bryan Baker - Fairfax Station, VA, 703-250-6117

Sid Edwards – Tallassee, AL, 334-283-4663

Tom Files – Kansas City, MO, 816-468-7087

Amy Jo Jones - Beavercreek, OH, 937-426-1567

Bob Kreimer – Ocala, FL, 352-873-8306

Robert Loch – Custer, WA, 360-366-3166

Jack Metcalf – Utica, OH, 740-892-2664

HEISEY NEWS is published and printed monthly, by Heisey Collectors of America, Inc. (HCA). Periodical postage paid at Newark. Subscription is limited to HCA members. First class mailing is available for an extra \$20.00, due with payment of membership. If you are having difficulty receiving your Newsletter, please contact the HCA Administrative Office Monday through Friday 8:30 a.m. - 4:30 p.m.

The opinions expressed in articles in HEISEY NEWS are those of the authors and not necessarily those of the organization. The Editorial Staff reserves the right to edit, with or without the consent of the author or to refuse any material submitted for publication.

Back Issues

Back Issues available from files are \$3.00 per issue plus shipping and handling

Advertising

Ads may be mailed to: HCA Advertising, 169 W. Church St., Newark, OH 43055; faxed to (740) 345-9638; or e-mailed to curator@HeiseyMuseum.org. Whenever possible, please e-mail your ad. Always include your MasterCard or Visa number and expiration date. When mailed or faxed, ads should be typed or printed on white paper with dark ink. Camera ready ads are accepted, but must follow line specifications outlined at the beginning of the advertising section. Ads containing reproductions will not knowingly be accepted unless clearly stated (e.g. Heisey by Imperial, etc.). HEISEY NEWS accepts no further liability. In the event of a typographical error, the incorrect portion of the ad will be run in the following issue, but HEISEY NEWS assumes no further liability. See advertising section for rates and deadlines.

Museum

Heisey Collectors of America, Inc., a non-profit corporation (tax-exempt status), owns and operates The National Heisey Glass Museum in Veterans Park, 6th and Church Streets, Newark, Ohio. Open year round, Tuesday through Saturday 10:00 a.m. – 4:00 p.m., Sunday 1:00 – 4:00 p.m. (except Jan. and Feb.), closed holidays. Other hours by appointment. Members admitted free.

Identification

HCA will attempt to identify unknown glass items. Send a color photograph, measurements, and a self-addressed, stamped envelope to the attention of the Curator. Other arrangements should be made in advance with the Museum staff. Please keep in mind that the Museum cannot appraise items. Identification is free to members, non-members \$5.00 per item.

Membership

To join Heisey Collectors of America or to renew your membership, contact the HCA Administrative Office Monday through Friday 8:00 a.m. - 4:30 p.m. Eastern Time. Associate dues are \$30.00 plus \$5.00 for each additional household member. Voting members pay an additional one-time fee of \$25.00. Please consider supporting the Endowment Fund by joining at one of the levels listed on the back page.

Museum Gift Shop

There is always someone in the Gift Shop during the Museum's hours of operation to help answer questions or take orders. When ordering by phone, please have a credit card ready. When ordering by mail, please be sure to include appropriate charges such as shipping and sales tax. Please note that the HCA member discount does not apply to original Heisey or special project items.

Shipping and Receiving

Delivery is made much easier when we have a complete street address, not a PO Box. We prefer to use UPS. If you have not received a package, please call the Administrative Office to confirm it was sent. We will assist you in tracing it. If your package arrives damaged, please contact your local UPS representative. We insure everything.

Donations and Loans to the Museum

If you would like to make a donation to the Museum or have questions regarding items on loan, contact the Curator. HCA reserves the right to accept or refuse items based on current holdings.

HEISEY CALENDAR OF EVENTS

2009

December Holiday Open House

December 5

Table of Contents

Utility Patents Associated with A.H. Heisey & Company (Part 8), Walter Ludwig	FC & 5-11
Heisey Calendar of Events	2
Message from the President, Sue Kilgore	3-4
Curator's Report, Walter Ludwig	4
HCA Welcomes New Members for August 2009	4
2010 All Heisey Benefit Auction, Dave Spahr	11-12
2010 HCA Benefit Auction Guidelines	12. 21
2010 Benefit Auction Contract	13-14
2010 HCA Benefit Auction Consignor Packing List	15
Heisey Glass Museum Playing Cards, Order Form (Green Deck)	16
1225 Plain Band, Joe Lokay	17-21
Heisey Goes to the Fair, Geri Pinion	22
1020 Phyllis Jug, Walter Ludwig	22
Advertisement Reprint, House & Garden, July 1923, 163 Monticello Etch	23
Study Club Directory	24
Club Notes	25-26
Advertising Guidelines	26
Classified Ads	26
Real Heisey in the Gift Shop	26
Dealer Directory	27
Museum Volunteers for August 2009	BC

MESSAGE FROM THE PRESIDENT

Sue Kilgore

Dear HCA Membership:

I am so pleased to be able to tell of you about our selection of a new director to work with us for HCA. This process began shortly after the Convention. I have read over 65 resumes, some of them "very interesting." The Executive Committee then read the ten that I felt were the most applicable. We narrowed it down to five and interviewed all but one. I am very pleased to tell you that the final three that we talked with were all great candidates for this position.



The Executive Committee then unanimously selected Susan Dawson of Westerville, Ohio. Susan has displayed the kind of qualities and initiative that HCA has been looking for to help us increase our

awareness and hopefully increase our membership and endowment as a result. She will be starting her new position on October 1 during the Vivian & Percy Moore weekend. This will give her a chance to see the workings of the Board of Directors, get questions answered and meet a lot of members. We hope that all of you will get the chance to meet Susan very soon. We know you will find her as enthusiastic, warm, and friendly, as we have.

As I am traveling to and from Newark, driving past the endless fields of soy beans, corn and horses; I am planning ways to make our Museum and "business" run smoothly. Hiring Susan is a good step in this direction and with the help of the Board and all of you we can DO IT and do it GREATLY!

I have started a recycle and clean out effort in the Museum. We are clearing out all of the old computer parts (Dick & Marilyn Smith are

helping with this part of the recycling project), organizing the offices and file cabinets (so we know where everything is suppose to be and how much we have of it), and doing a really good cleaning of the shipping room (organized by my husband, Dan, and a volunteer crew during the Moore weekend – who knows what we will find in there). As the owner of my own business, I feel that it is very important to know what we have so that we don't reorder when we don't need to. This will also help save HCA money, making sure that all of the bills that do come to us are legitimate and cost effective. So, we are also doing a careful study of the expenses that we are currently paying to see if there is anywhere else that we can save money. We have found a few small ones, so far. I really appreciate the Executive Committee and our staff, especially Walter, for their help with my big plans.

I hope that a lot of you are coming to the Moore weekend and festivities. I know we will have pictures and stories to share with you in the November Newsletter, but seeing all of you in person is so much nicer. I know the auction will be a great fund-raiser for us. The glass is absolutely gorgeous with many not often seen pieces.

Dick and Ginny Marsh would like you know that Dick is doing well since his diagnosis of adenocarcinoma. He has had radiation treatments and will now be having chemotherapy. They have loved hearing from friends, near and far. We all wish them the best everyday. Ginny said they will be at the select auction and we are looking forward to seeing them, too. Their address is 4532 Newton Rd, Newark, OH 43055.

It is with sadness that we inform you of the passing of another of our long time members. Robert "Bob" McElheney of Toledo, Ohio, died on August 22. Bob and his wife Joanne have been members of HCA since 1993 and Bob served as Treasurer of the organization for one year. He has, I am told, a great collection of

sugars & creamers. We are sure he will be greatly missed by family and friends.

We also are saddened by death of Odell Johnson of Bloomington, Minnesota. Odell, who was 92, and Virginia have been members of HCA since 1975 and founding members of the Northwoods Heisey Club of Minnesota. We will miss his many stories about a Swede named Ollie. I know all of our membership will keep Odell and his family in our thoughts and prayers.

As the leaves begin to "fall" and the air turns more crisp, I hope that we all have more time to go Heisey hunting and, of course, come back with the best, the biggest, and the most finds. At least with Heisey, we don't have to "skin it," debone it, or eat it. Get the fall/hunting references?

Sue Kilgore ♦

CURATOR'S REPORT

Walter Ludwig

The year is certainly moving fast. There is already the scent of fall in the air and leaves are falling here in Newark. I had to have the great big silver maple in front of my house removed (a car came around the corner a bit too fast, but my tree stopped it cold), so I will have a lot fewer leaves to rake this year. Unfortunately there will be a lot less shade until the replacement tree reaches maturity.

By the time your read this, the excitement of the Percy and Vivian Moore weekend will just be a memory here in Newark. I hope you put in a few bids in the auction, I am sure there were bargains to be had.

Many of you wonder how you can support the Museum. Most of you know that we take donations of Heisey glassware to sell in the Gift Shop. But you may not have known that we also take as donations books or magazines on Heisey glass or any glass topic. These usually

sell fairly quickly, so they are a good money maker for the Museum. I would especially like to see donations of either of the two Bredehoft books (Heisey Glass: 1896-1957 or The Collector's Encyclopedia of Heisey Glass: 1925-1938). Both of these books are no longer available from the publishers. We have many people who come to the Museum looking for good research books and unfortunately we have only a few titles to sell them and none of them are comprehensive guides to Heisey wares. So if you have these books lying around and they are no longer of use to you, please remember your Museum.

I will be starting the process of cleaning our collection shortly. This is a project that has not been done since the Museum was reorganized two years ago. If you have some spare time on a Monday let me know and I will schedule a session. One of the biggest compliments we got during Convention was how great the glass looks in the Museum. Unfortunately, if we want to keep it that way we have to put in some effort to keep it looking like it does.

Our dining room table has been changed by Phyllis McClain and Marilyn Smith to show off Marigold Twist for the fall season. It may not be your favorite color, but seeing it all together on a table is really quite impressive

What have you found to add to your Heisey collection lately? Maybe, it is time to take one more excursion to those outside flea markets before they close for the season. As I keep reminding you, Heisey will not find you; you have to go out and find it. ♦

**HCA WELCOMES
NEW MEMBERS
FOR
August 2009**

Michele Thomas, KY
J. Edward and Maureen Sweet, VA

UTILITY PATENTS ASSOCIATED WITH A.H. HEISEY & COMPANY (PART 8) Walter Ludwig

We are now ready to examine the last of the utility patents that are associated with A.H. Heisey & Company. We have covered the patents issued up to 1930 and there are actually only a few more patents to look at. It would seem that fewer creative ideas were coming out of the factory. We only have one patent left to discuss that deals with the process of glass making and a few that deal with innovative designs of new pieces of glassware.

We will start with utility patent 1,966,611 issued on July 17, 1934, for a "shaker." The patent was issued to "Ray C. Cobel, Newark, Ohio, assignor to A.H. Heisey & Company, Newark, Ohio, a partnership." The design drawing for this piece is pictured on the cover of this issue. I am sure that you have no trouble recognizing the 4225 Cobel cocktail shaker that was named after its designer.

The Twenty-first Amendment to the U.S. Constitution which repealed the Eighteenth Amendment was fully ratified on December 5, 1933 thereby ending the period of Prohibition in the United States. You might think that Heisey was late in getting the new shaker to the market given the issuing date on the patent. But Heisey was definitely forward thinking in this area. The patent states that the application for the patent had been filed on December 19, 1931 and renewed on May 31, 1934. It is obvious that the patent office was very slow in processing this application. Heisey had read how the tide was turning against Prohibition and wanted to be first on the market with a new innovative cocktail shaker.

The patent details the previous types of cocktail shakers that were made mostly all metal or glass with a metal top. It points out the problems of such shakers including corrosion and the

inability to clean thoroughly, leading to unsanitary conditions. It goes on to say:

"One of the objects of my invention is to provide a shaker of the type indicated which will be very sanitary and which will have all of its parts readily accessible for cleaning.

"Another object of my invention is to provide a shaker of the type indicated which will have all of its parts made of some material such as glass, which will not corrode, rot or deteriorate in any manner.

"Another object of my invention is to provide a shaker of the type indicated which will have a closure for the top of the container, of such a type as to prevent any leakage therefrom.

"Another object of my invention is to provide a shaker of the type indicated having a strainer adapted to be mounted in the upper end of the container.

"In its preferred form, my invention contemplates the provision of a shaker of the type indicated which comprises a container or body portion made in any desirable shape or of any material desired, but preferably of glass. This container is provided with a neck in which is adapted to be mounted a member having a strainer formed in its lower end and a pouring lip formed on its upper end. This member is made of some material which will not rot, corrode or deteriorate, and this member will fit into the upper end of the container in such a manner that there will be no leakage between it and the container. The upper end of this member is provided with a seat which is adapted to receive a stopper of the same material, which is so fitted therein as to prevent leakage."

Obviously, the application as written covers all of the three-part cocktail shakers that Heisey made including the 1405 Ipswich, the 4054 Coronation, the 4036 Marshall, and the 6009A Roundelay. This surely was one of Heisey's

most successful design patents and served them in good stead for many years.

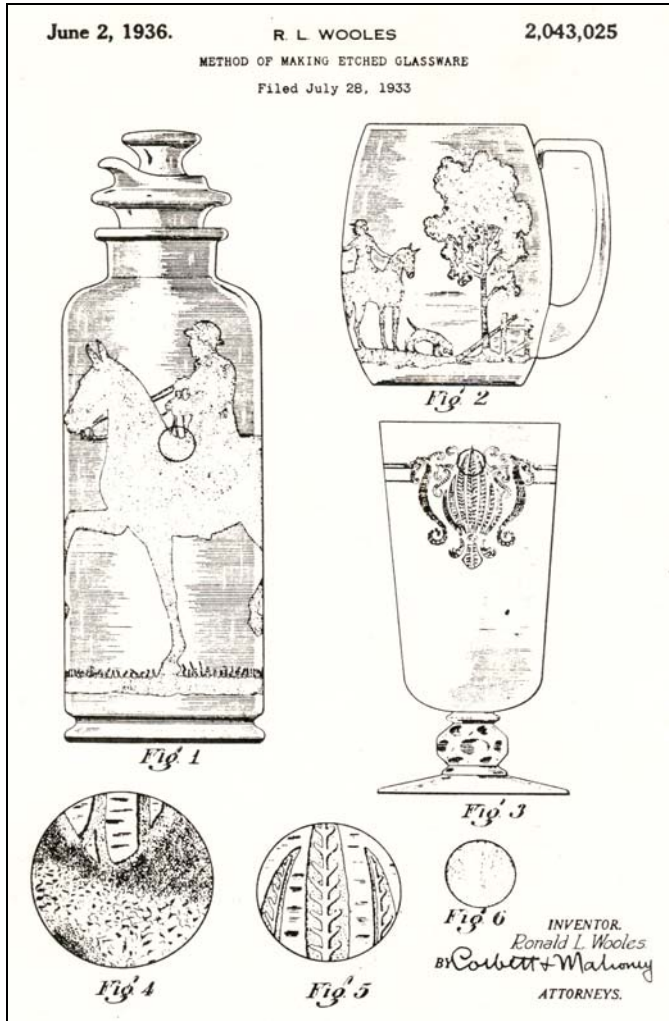

Patent 2,043,025

The next utility patent is 2,043,025 issued on June 2, 1936 to Ronald L. Wooles, Newark, Ohio, assignor to A.H. Heisey & Company for a "method of making etched glassware." This is the patent for Heisey's unique deep plate or silhouette etching process that was used for so many of the beautiful decorations that were put on Heisey barware starting in the mid-1930s. In the December 2007 and January 2008 issues of the Heisey News, I wrote extensively on this patent so I will refer you to those articles for further reading.

Patent 2,074,974 was to be the last utility patent issued to the company for a piece of glass making equipment. It was issued on March 23, 1937 to Charles T. Stewart, Newark, Ohio,

assignor to A.H. Heisey & Company for a "glory hole." This invention was for a small, movable glory hole which could be used in the fire polishing process of glass finishing. The patent states:

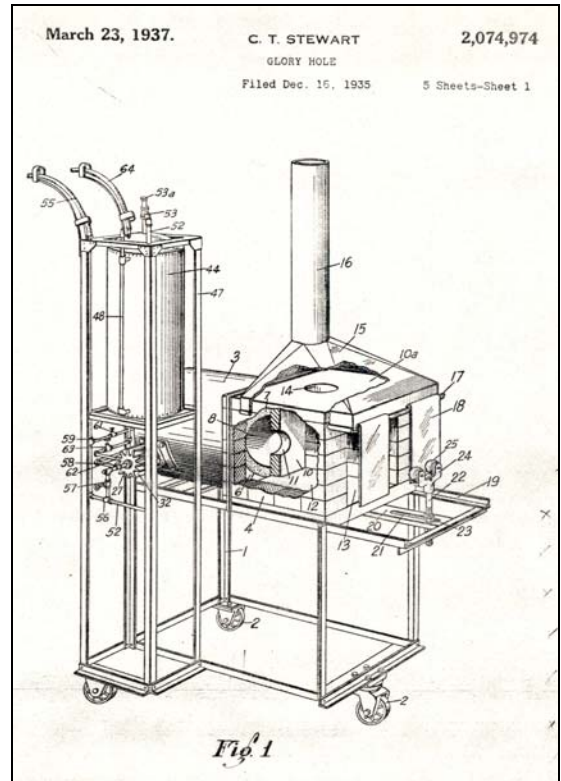

Patent 2,074,974 – Illustration 1

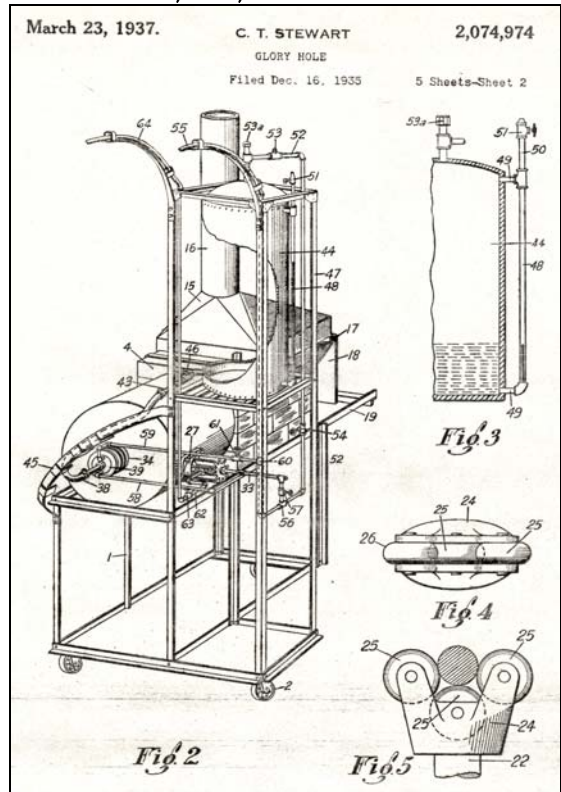

Patent 2,074,974 – Illustration 2

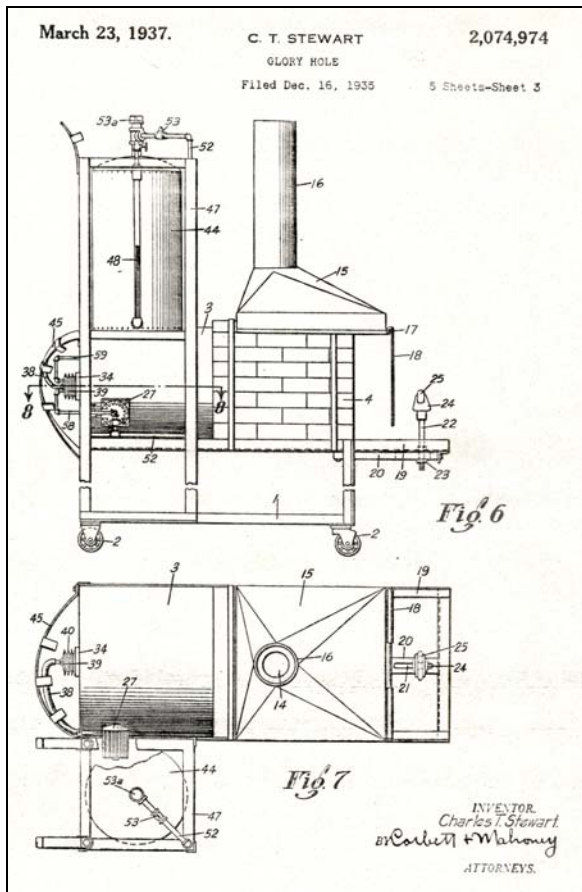

Patent 2,074,974 – Illustration 3

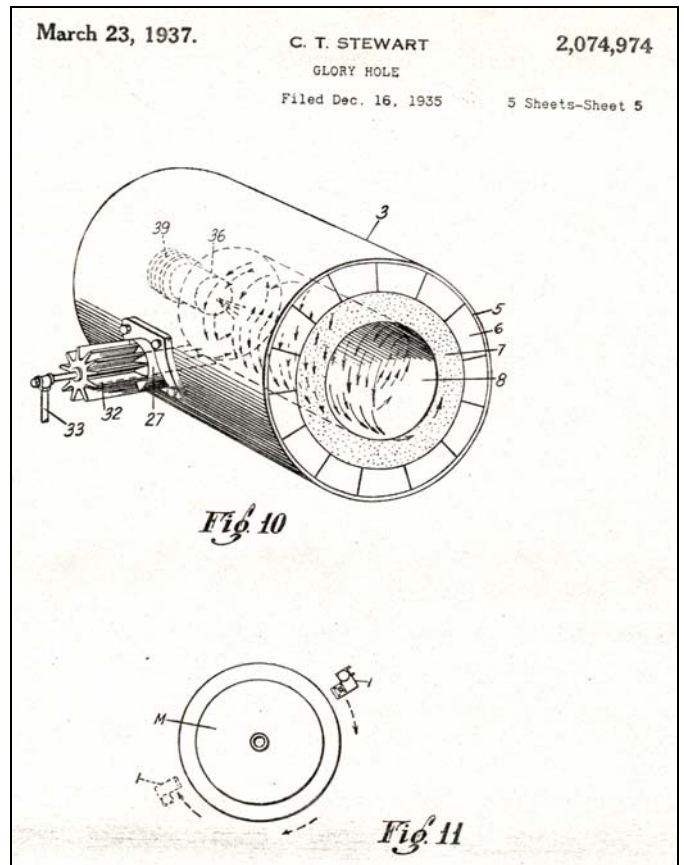

Patent 2,074,974 – Illustration 5

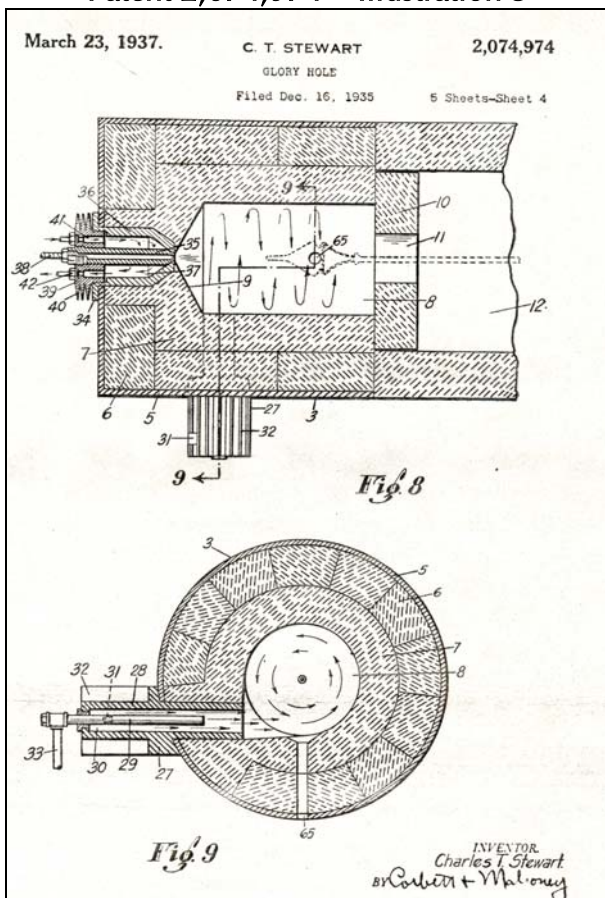

Patent 2,074,974 – Illustration 4

“In its preferred form my invention contemplates the provision of a glory hole which is mounted on a frame carried by wheels or rollers so that it may be moved to any desired position. This glory hole embodies mainly a substantially cylindrical combustion chamber in which the article to be finished is adapted to be placed. Means is provided for injection fuel tangentially into this chamber and for drawing it towards the front of this chamber so that the flame in the combustion chamber will swirl around in said chamber, and consequently around an article placed therein. I also provide means for injecting oil or other suitable substances into this chamber to aid combustion and to produce a carbon deposit of free carbon on the article which will serve as a lubricant to prevent the shaping tools, subsequently used, from marking the article. I also provide a chamber in front of the combustion chamber in which the greater portion of the snap or rod, that holds the article place in the combustion chamber, will be disposed during the heating of the article, in order to keep the snap or rod warm so that

when it is subsequently used for picking up hot articles, it will not cause breakage thereof."

The illustrations accompanying this patent are extensive and give you an idea on how this piece of equipment was supposed to work. Obviously a mobile glory hole that concentrated the produced heat necessary to work glass could result in significant fuel savings for the company as well as saving the moving of hot glass across the shop in order to finish the glass making process.

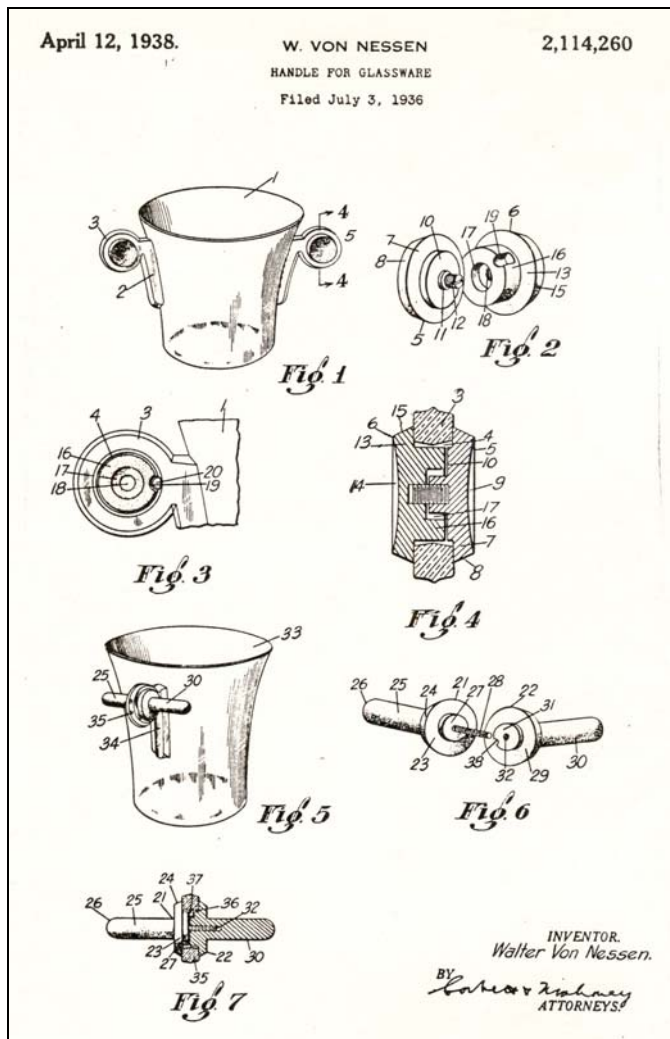

Patent 2,114,260

Patent 2,114,260 was issued on April 12, 1938 to Walter von Nesson, New York, N.Y., assignor to A.H. Heisey & Company. This patent covers the unique handles that are found on the 1483 Stanhope pattern. Both the button inserts and the T-inserts are shown in the patent illustration. The Stanhope pattern was first issued in 1936

and the application for the patent was filed on July 3, 1936. Walter von Nesson is the New York industrial designer that Heisey commissioned to design several patterns during this period. Stanhope is one of the more striking designs that he came up with. The innovation of using Plascon (a type of plastic) inserts to dress up the pieces set the pattern apart from anything else produced at the time.

The patent reads, "In its preferred form my invention contemplates the provision of a handle structure which is adapted to be removably attached to the ordinary handle provided on glassware, for example, to the handles of a glass sugar bowl or to the handle of a glass cream pitcher. This handle structure is preferably made of two parts which interfit and which are adapted to be positioned in the opening usually provided in the glass handle. These two parts cooperate with each other to produce a composite handle structure which is much more pleasing in appearance than the ordinary handle structure and which can be gripped much more effectively than the ordinary handle structure. The two parts of the handle structure which are attached to the ordinary glass handle are preferably of different material from the article to which they are applied and may be of different color in order to increase the ornamental effect.

It is a shame that the buying public never really felt comfortable with this pattern. It is quite possible that it did well in the cities but was just too advanced a design for the rest of the country.

Patent 2,272,867 was issued on February 10, 1942, to Ray C. Cobel assignor to A.H. Heisey & Company and covered the design for a "container top." This invention was for a new type of lid for syrups. As stated in the patent, "In the past, many attempts have been made to provide a suitable top for syrup containers of such a nature that the syrup could be readily dispensed from the container and the flow of syrup from the container could be quickly and effectively interrupted without dripping of the

syrup. A number of these prior art devices include hinged or sliding closures. However, these closures do not effectively prevent dripping of the syrup and also tend to stick and become inoperative if not used for a considerable period. Also, most of these devices have been of a complicated structure and expensive to manufacture."

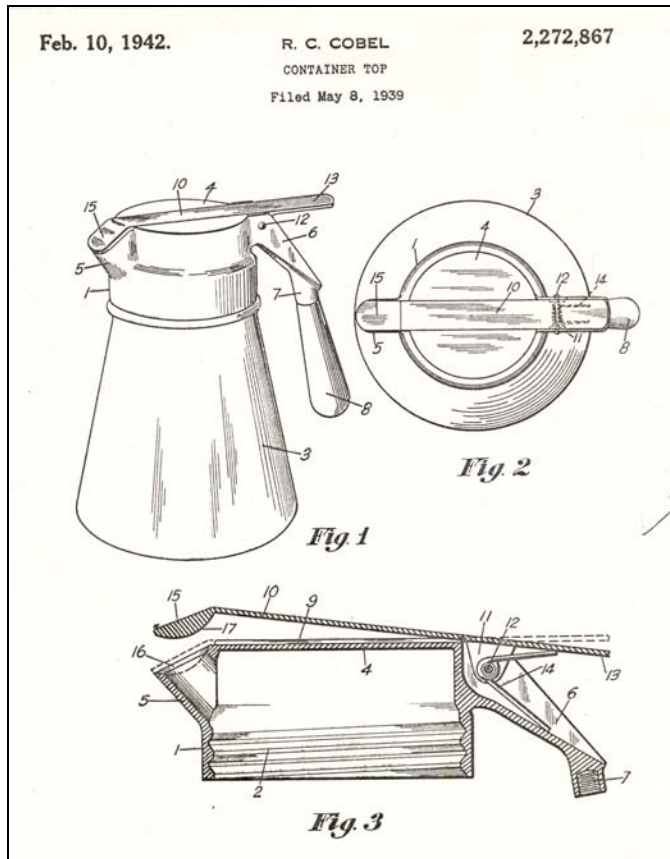

Patent 2,272,867

In an attempt to rectify these problems, Ray Cobel came up with a new type of screw on syrup top that incorporated a pouring spout and a hinged section of the lid. This top would have been designed to be used with the 1503 Crystolite syrup. The application for the patent was made in 1939 and took until 1942 to be granted.

In point of fact, this is not the lid that one usually sees on Crystolite syrups. That lid has a retractable slide (rather than a lifting strip). Also, the spout is not angled down from the top section. Heisey probably found a commercial supplier for this new lid that could provide it

cheaper than for the Cobel designed lid. One sales flyer for Crystolite shows this new lid on the syrup. The syrup is not illustrated in the Crystolite Wartime Salesman. I would be interested to know if anyone has a Crystolite syrup with this type of lid. The newer type lid was also used on the 1567 Plantation syrup.

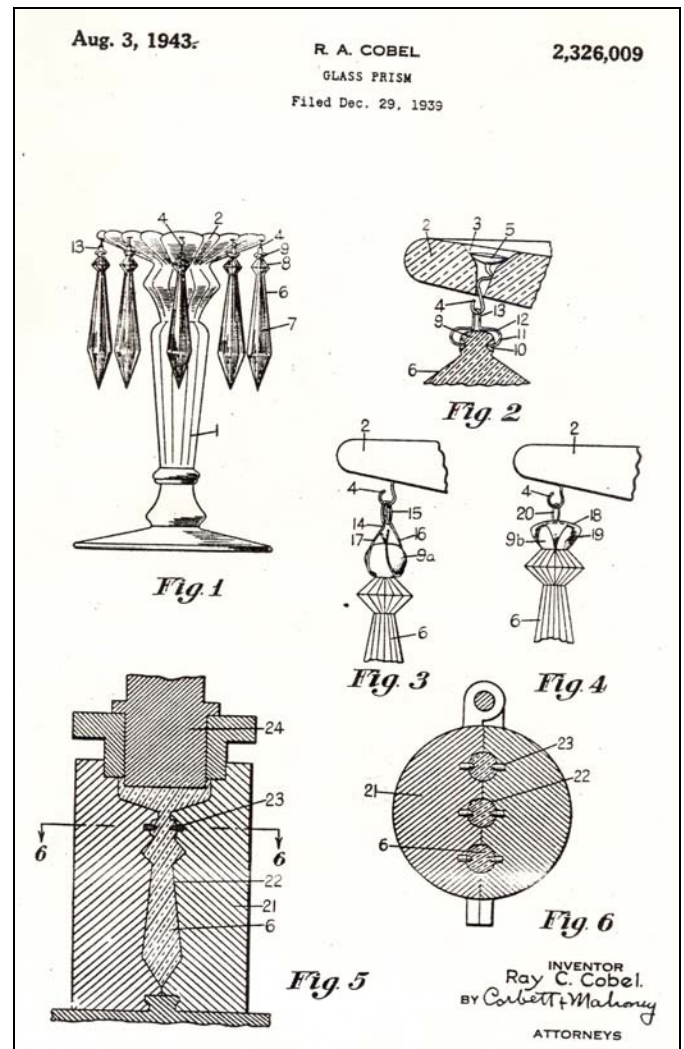

Patent 2,326,009

Patent 2,326,009 was granted on August 3, 1943 for a "Glass Prism." The inventor is listed as Ray Cobel. The application for this prism was made on December 29, 1939. Heisey, as did all of the American elegant glass manufacturers, imported all of its prisms from Europe, mainly from the glass making areas of Czechoslovakia. The onset of World War II meant that access to this supply was cut off. Heisey quickly realized this and Cobel developed this new prism which could be made in-house. Cobel also addressed

some of the drawbacks of the old prisms by making it in one piece rather than two and providing a different hanging mechanism for the prism.

Heisey did produce these prisms in several different sizes and they can be found on the candelabra that Heisey produced during the war. Many feel that these prisms are inferior to the European ones and even Heisey reverted back to European suppliers after the war was over.

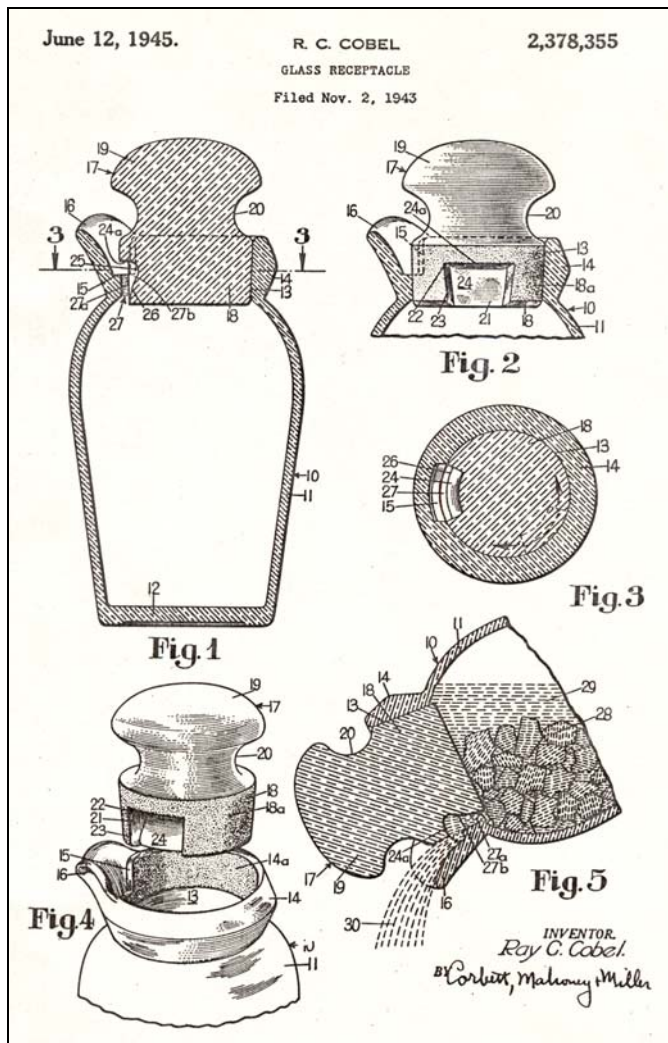

Patent 2,378,355

The last utility patent that was granted to A.H. Heisey & Company was 2,378,355 for a “glass receptacle.” The patent was issued on June 12, 1945 and Ray C. Cobel is listed as the inventor. Given that Heisey was producing very few new things during the war years; that makes this cocktail shaker rather interesting.

The patent states, “Generally speaking, my improved glass receptacle comprises a body portion provided with an opening in the upper end thereof, a pouring lip or spout associated with the opening, a removable glass stopper for closing and sealing the opening, and means formed in the stopper adapted to cooperate, by registry, with means formed in the body portion between the opening and pouring lip, to permit the contents of the receptacle to be poured or discharged therefrom when desired.”

The illustration shows the uniqueness of this cocktail shaker. The stopper is an adaptation of the usual stopper that would go into the 4225 Cobel cocktail shaker and the body is a simple modification of the body of the same shaker. Here, however, we have a two part cocktail shaker rather than a three part.

We have no record of this shaker ever being offered to the public, but the Museum does have an example of the shaker which was acquired from the Anne and Tim Heisey estate. No pattern number has ever been found for the shaker, so it was assigned and named the 8085 Granville.

In our Museum archives we have a copy one further utility patent that is associated with the company. Patent 2,478,864 was issued on August 9, 1949 to Annie Lee Dillon and Mary G. Dillon of Raleigh, N.C. This is the patent for epergnettes that had been developed by the ladies to transform candelabra into exciting floral centerpieces. The patent discussed epergnettes in general and does not mention A.H. Heisey & Company. Heisey did make several varieties of epergnettes based on this patent. The story of the two ladies and the epergnettes was told in two Heisey News cover stories in the January 2006 and September 2008 issues. The cover article covered two different promotional flyers that were produced by A.H. Heisey & Company to promote the various epergnettes that the company made.

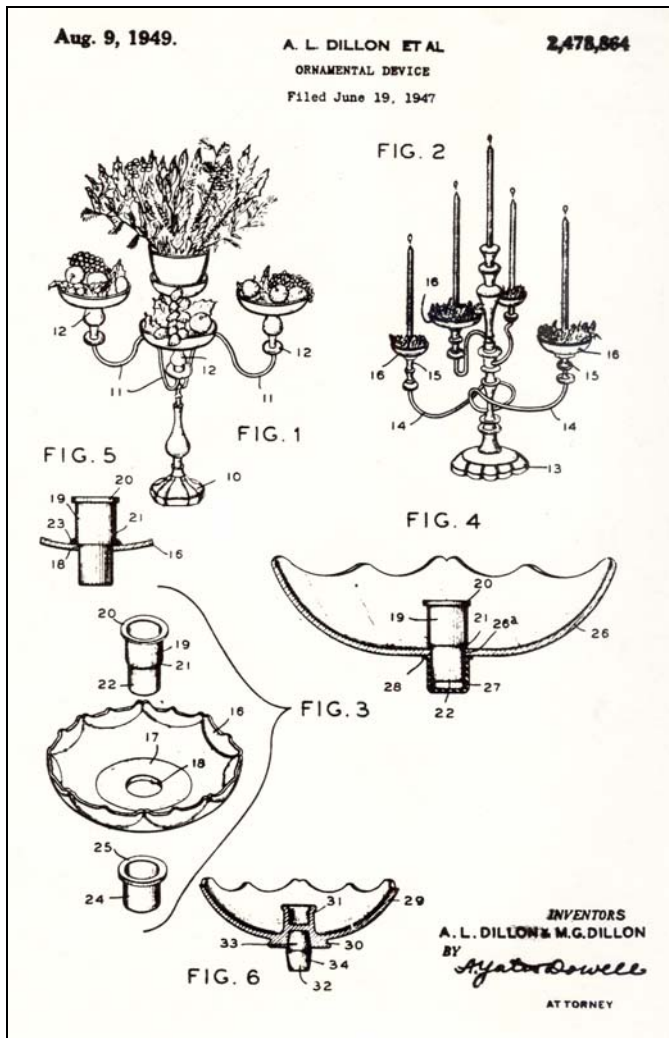

Patent 2,478,864

This concludes our discussion of the utility patterns of A.H. Heisey and Company. It was only through constant innovation that the company was able to continue in production and remain profitable. We have seen inventions that were meant to save the company time and money in the production of its goods. Other inventions offered innovative solutions to accomplish the many different tasks that you found in a glass factory. To us, probably the most exciting of the utility patents are those that display a new type of article to be produced in glass and then brought to the public. These inventions provide part of the answer as to why the company was successful in a very competitive marketplace.

It has taken us eight articles to cover all of the utility patterns of A. H. Heisey, I hope you all have enjoyed them. ♦

2010 ALL HEISEY BENEFIT AUCTION

Dave Spahr

The 37th annual HCA All Heisey Auction benefiting the National Heisey Glass Museum will be held at the GMP Local #244 Union Hall at 350 Hudson Ave., Newark, OH 43055 for the third consecutive year. Craig Connelly and his fellow auctioneers will again preside over the auction! Expect some great food too! As of press time, we have not set the date but it will be in late March or early April 2010.

This HCA event is our largest fund-raiser. Very dedicated volunteers put this event together for YOU. HCA makes its money from the consignment fees collected, the auctioning of donated glass, and from glass not sold at the auction but later in the Gift Shop. As always, we are looking into ways to improve and expand our auction to make it better for purchasers and consignors. We are also looking for activities that would fit nicely with the auction. If you have any ideas let me or any Board member know.

In this issue of Heisey News, you will find a consignor's packing list and the Auction contract. You can copy these for use. We also hope to have these on our website soon for you to download and use. As before, each member and household member can donate unlimited amounts of Heisey glassware and can consign up to forty (40) lots each. (Please use another copy of the packing list to list items 26 through 40.) There is no limit to the number of items in each lot and we are encouraging each consignor to size each lot so it is valued at more than \$25. The auction committee reserves the right to modify lots but will do so sparingly. Please note that we have expanded the glass we will accept. In the past we accepted only glass made by the A. H. Heisey & Company. This year we are also accepting glass made from Heisey moulds by other manufacturers. Glass not made from Heisey moulds will not be sold and will be

returned at the consignor's expense or become a donation to HCA.

Please read over the auction agreement carefully, as it, once signed, is an agreement between you and us. Please use the packing list to list items and group them into lots as you wish them to be. Remember to put a "D" beside the lot number(s) on the packing lists for those lots you wish to donate to HCA. Please be certain the packing list includes ALL of your items, that you fill in each line completely - Pattern #/Name, description, cut/etch, color, if marked, and provide the condition. Don't forget to sign and date the auction contract and submit it along with your packing lists. Both should be in your box of consigned or donated glass. As last year, those who donate glass will be given a donation slip to use at tax time. There will be no donation slip given for the consignment fee for those who consign glass.

The success of this auction depends on the quality and quantity of glass consigned and donated. We are requesting you to send (donate, consign) GOOD DAMAGE FREE GLASS. Please look through your Heisey and consign some to us to help support YOUR museum. Consignments and donations for the auction must be received by **January 15, 2010**. The sooner your items are received the better, since they must be checked in, inspected, cataloged, and repacked for the auction by volunteers. If you would like to help do this, please contact me!

Many dedicated HCA members including most board members volunteer to help to make this auction a success. We, as always, need help to catalog the glass, prepare for the auction, and help at the auction itself and after the auction to cleanup and take glass back to the Museum for our successful absentee bidders. If you would like to volunteer please contact the Museum or me. We are counting on your participation to make this auction the best ever!

Four things make for a great auction: great facilities, great help from volunteers, great glass,

and a great group of buyers with deep pockets to purchase the glass. We have the first thing;- we hope to get the last three! Please contact us if you would like to volunteer to help. Please look through your Heisey and consign or donate good glass to us to help support your Museum. Please plan on attending this great event!

For more information or if you need answers to questions or ideas for special activities, please contact Dave Spahr by telephone 937-372-7166, or email masdgs@aol.com. ♦

2010 HCA BENEFIT AUCTION GUIDELINES

1. The owner/consignor/member (owner) and the Heisey Collectors of America, Inc. (HCA). HCA shall enter into an agreement for glassware items consigned or donated for sale for the benefit of the National Heisey Museum.
2. All items consigned or donated for sale are to be made by A. H. Heisey and Company or by other manufacturers using Heisey moulds.
3. Each HCA member is considered an owner and can donate an unlimited number of items to be sold at the auction by HCA. HCA, at its discretion, has the right to add any donated item it chooses to its glass collection or sell in the Museum Shop.
4. Each owner may consign a maximum of forty (40) lots for sale at the benefit auction. There is no limit of the number of items in each lot. The auction committee retains the right to increase/decrease the size/makeup of any lot. The committee will not combine lots from different owners.
5. Owners of glassware for sale will be charged on the following sliding scale of commission per lot: \$5 - \$50 = 40%; \$50.01 to \$200 = 30%; \$200.01 - \$400 = 20%; \$400.01 - \$750 = 15%; \$750.01 and over = 10%.

Continued on page 21.

2010 BENEFIT AUCTION CONTRACT



Heisey Collectors of America, Inc.
169 West Church Street
Newark, Ohio 43055
Phone: 740.345.2932
Fax: 740.345.9638
www.HeiseyMuseum.org

This agreement is hereby entered into between (Please Print)

Owner / Consignor / Member _____

Address _____

City _____ State _____ Zip _____

Daytime Phone _____ Fax or E-mail _____

and Heisey Collectors of America, Inc., hereafter referred to as HCA, for glassware items consigned or donated for sale for the benefit of the National Heisey Glass Museum.

Tentative Auction Date: _____

Auction Location: BMP Local #244 Union Hall, 350 Hudson Ave., Newark, OH 43055

Consignments:

All items consigned for sale or donated are to be made by A. H. Heisey and Company or by other manufacturers using Heisey moulds. The owner/ consignor / member, hereafter referred to as the owner, agrees to accept all responsibility for providing merchantable title for all glass sold.

Each owner may consign a maximum of forty (40) lots to the auction. A list of glass being consigned or donated and prepared by the owner is attached as an integral part of this contract. There is no limit on the number of items in each lot, but HCA retains the right to increase / decrease size / make up of each lot. Each owner may donate an unlimited number of lots to HCA for sale at the auction. HCA, however, at its discretion, will consign donated items for auction, add donated items to the museum collection, and/or sell donated items in the museum shop.

The HCA Auction Committee is authorized to reject any glass not deemed acceptable to HCA standards for this auction. These items may be returned to the consignor if they desire, at their expense. Otherwise, these items become the property of HCA.

Commission:

Owners of glassware to this sale will be charged on the following sliding scale of commission per lot: \$5.00-\$50.00= 40%; \$50.01-\$200.00= 30%; \$200.01-\$400.00= 20%; \$400.01-\$750.00= 15%; \$750.01 and over= 10%.

Settlement:

Settlement for glass sold will be made in full not later than fifteen days after the completed auction from the HCA Auction escrow account. Said account is set up and operated consistent with ORC Section 4707.024. Collection of funds, bad checks, debts, and unpaid auction lots is the responsibility of HCA.

Responsibility:

It is the responsibility of the owner to deliver the glassware to the National Heisey Glass Museum on or by January 15, 2010. HCA accepts responsibility for the glass after it is received at the Museum and until it is sold except that any glass damaged in shipment to the Museum will be referred to the shipper and owner. All glass damaged or lost while in the possession of HCA prior to sale will be valued by a qualified appraiser or appraisers and the owner will be paid on this basis, less commission.

Bidding:

The minimum opening bid on a lot will be at least \$5.00. The minimum incremental bid increase will be \$2.50. In the event no bid is received on a lot, that lot becomes a donation to HCA.

The owner and HCA both agree that absentee bids will be accepted by HCA. Per HCA policy, the minimum absentee bid on a lot will be \$15.00 with a minimum opening bid of \$5.00. Absentee bids are bids left by buyers prior to the auction and are executed in a competitive manner. We do not use the full bid amount as a starting bid. Bidding is initiated in the audience and then offered on behalf of the absentee bidder at the next increment continuously until bidding has stopped. HCA reserves the right to accept or reject any and all absentee bids. Example: Absentee bidder leaves a bid with a maximum amount of \$500.00. After item is sold through competitive bidding, the absentee bidder is successful for \$325.00. HCA is not responsible for misfiled bids that are not executed.

Absolute Auction:

All items are to be sold at an **absolute auction** and not at a reserve auction **except** HCA and the owner agree there will be a minimum opening amount (see Bidding above) on all lots without exception. Owners cannot bid or have others bid on their behalf on their own items.

“Absolute Auction “ and “Reserve Auction” as defined by ORC. 4707.01:

“Absolute Auction” means an auction of real or personal property to which all of the following apply:

- 1) The property is sold to the highest bidder without reserve.
- 2) The auction does not require a minimum bid.
- 3) The auction does not require competing bids of any type by the seller or an agent of the seller.
- 4) The seller of property cannot withdraw the property from auction after the auction is opened and there is a public solicitation or calling of bids.

“Reserve Auction” means an auction in which the seller or an agent of the seller reserves the right to establish a minimum bid, the right to reject or accept any or all bids, or the right to withdraw the real or personal property at any time prior to the completion of the auction by the auctioneer.

General Auction Terms and Conditions:

- 1) Payment: Cash, travelers check, certified check or personal check (if approved by HCA). MasterCard and Visa cards are accepted. 5% buyers premium. Buyers premium deleted for cash or check payment. Cash only payment may be specified for individual bidders at HCA’s request.
- 2) HCA has endeavored to describe all items to the best of their ability, however this is not a warranty.
- 3) All items are sold as is and where is. The auctioneer has the right to make any verbal corrections at the time of sale and to provide additional information. Inspection is welcomed during preview and anytime before the item is sold.
- 4) In the case of a disputed bid the auctioneers have the authority to settle disputes to the best of their ability and their decision(s) is/are final.
- 5) The auctioneer has the right to reject any bid raise not in line with established bid increments.
- 6) All sales are final and all items must be paid for each day of sale.
- 7) Live telephone bidding may be available at HCA’s option and under special terms (contact HCA).
- 8) HCA is licensed as an auction firm by the Ohio Department of Agriculture and bonded in favor of the state.
- 9) HCA will provide auctioneers licensed by the Ohio Department of Agriculture and bonded in favor of the state.
- 10) Buyers assume full responsibility for items once they are sold unless otherwise specified by HCA.
- 11) Bidding on any item indicates acceptance of these terms.

OWNER SIGNATURE: _____ Date _____

HCA REPRESENTATIVE SIGNATURE: _____ Date _____

2010 HCA BENEFIT AUCTION CONSIGNOR PACKING LIST

Owner / Consignor / Member: _____



SHIP TO: HCA Auction, 169 W. Church St., Newark, OH 43055

DEADLINE: January 15, 2010

Two signed copies of the contract must accompany your auction glass.
 Please put a "D" beside the lot number if the lot is to be donated to HCA.

Lot #	Qty	Pattern #/ Name	Description	<i>Cut / Etch</i>	Color	MARK	Damage
1							
2							
3							
4							
5							
6							
7							
8							
9							
10							
11							
12							
13							
14							
15							
16							
17							
18							
19							
20							
21							
22							
23							
24							
25							

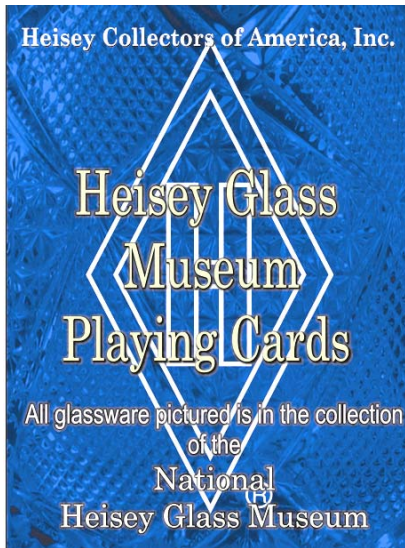

HEISEY GLASS MUSEUM PLAYING CARDS

Edition 3 (green deck) of Heisey Glass Museum Playing Cards are now in. In addition, we have for sale a limited number of uncut sheets (21" x 25") which will be suitable for framing. This deck features the Heisey animals and animal related items. The full color pictures are stunning and will make a good learning tool as well as a nice gift for all of your glass collecting friends. We will ship as soon as available. Orders for Card Cases (Cobalt) and the Red deck may also be placed on this form.

Name _____
 Address _____
 City _____ State _____ Zip _____
 Phone and/or E-mail _____

I wish to order:	Total
_____ (number) Heisey Glass Museum Playing Cards (Green) @ \$10 each	_____
_____ (number) Heisey Glass Museum Playing Cards (Red) @ \$10 each	_____
Shipping per deck \$ 1.50 (can be picked up at Gift Shop)	_____
_____ (number) Uncut sheets of Heisey Playing Cards (Green) @ \$25 each	_____
_____ (number) Uncut sheets of Heisey Playing Cards (Red) @ \$25 each	_____
Shipping per uncut sheet @ \$5.00 each (can be picked up at Gift Shop)	_____
Grand Total (tax will be added when appropriate)	_____

Check # _____ Visa _____ Master Card _____
 Card Number _____ Exp _____

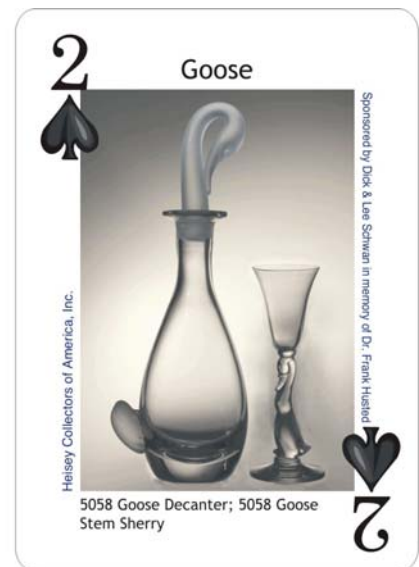
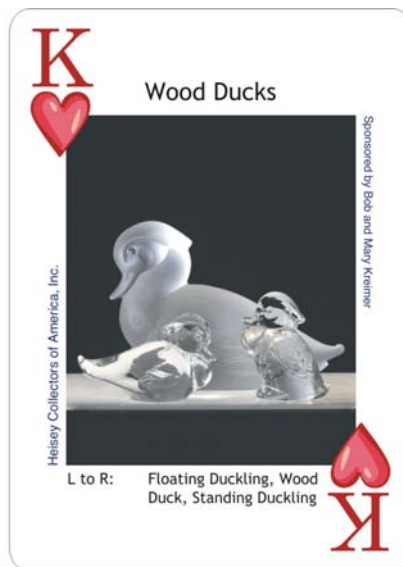
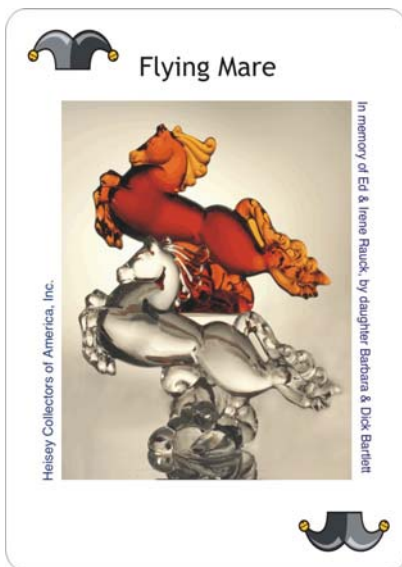



Vogel 4, Page 106

1225 Plain Band Joe Lokay

Pattern 1225 was introduced in 1897 and lasted until about 1910. It started with about 95 items in the pattern. It grew to a total of 115 items, and then declined to 16 items in 1910. Pattern 1225 was made in crystal only, except later some of the small pieces were made in Custard. These were used mostly for souvenirs. The most common of the Custard items is the sherbet which is often mistaken for a toothpick. The sherbet is wider and has a plain rim where the toothpick has a beaded rim.

The pattern started four years before the Diamond H, so most of the pieces are unmarked. Items produced after the Diamond H was adopted may or may not have the

Diamond H, depending on whether or not the mold was modified to include the trademark. A.H. Heisey & Company applied for two design patents for 1225 on November 12, 1897. Design patent #28180 for the cream and patent #28181 for the spoon holder were granted on January 18, 1899.

The design of the pattern is plain with a bulging band at the bottom. There is a sawtooth design above and below the bulge and beads on the top edge where appropriate. Vogel called the pattern Sawtooth Band; however, the name Plain Band is in more common usage. The plain design makes the pattern especially adaptable for decoration. The early Heisey catalogs offered 1225 plain or engraved with the #28, #30 or #33 engravings. Decorations were #15 Gold, #16 Green, #17 Bronze, and #18 Pink.

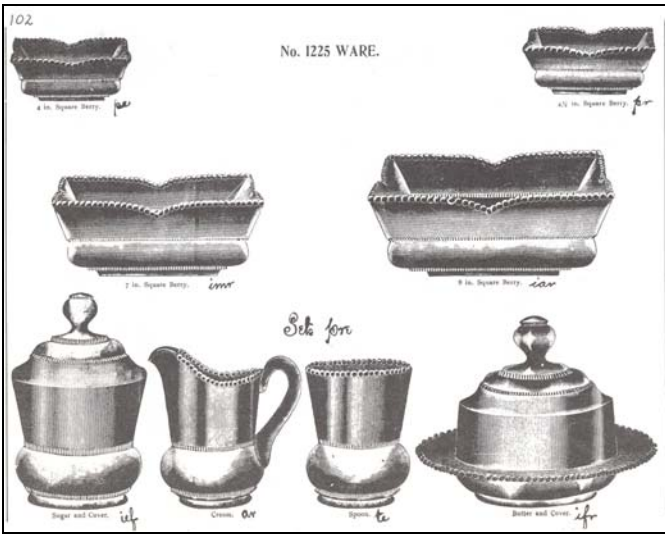

Vogel 4, Page 102

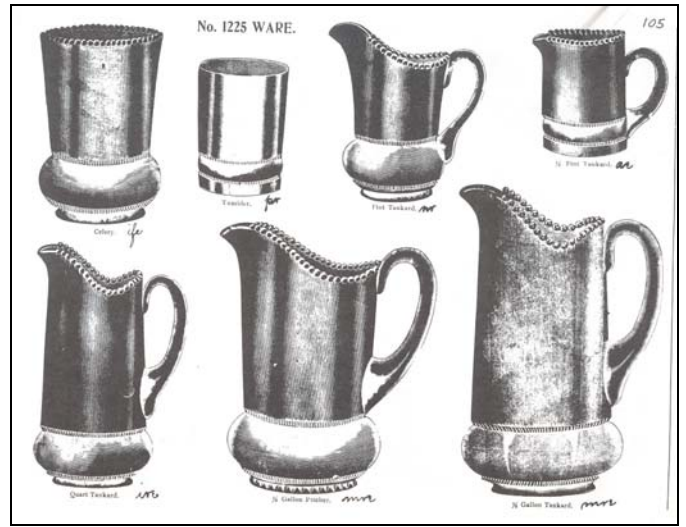

Vogel 4, Page 105

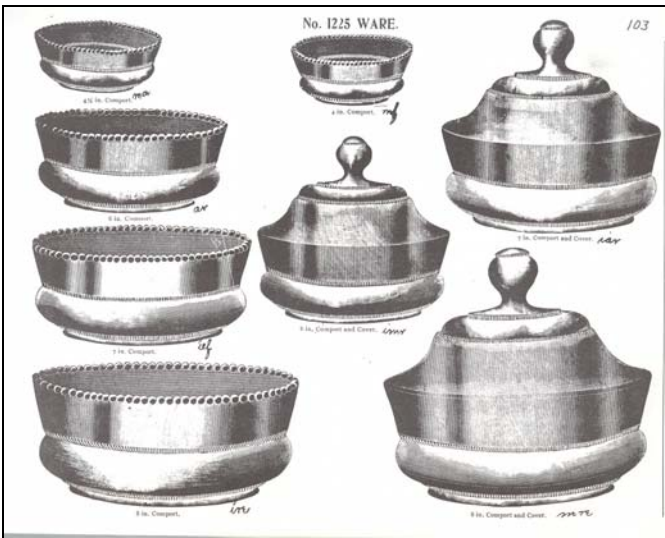

Vogel 4, Page 103

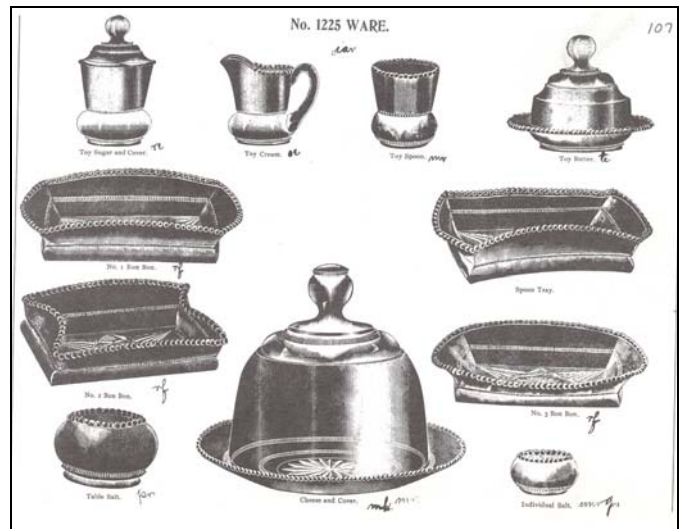

Vogel 4, Page 107

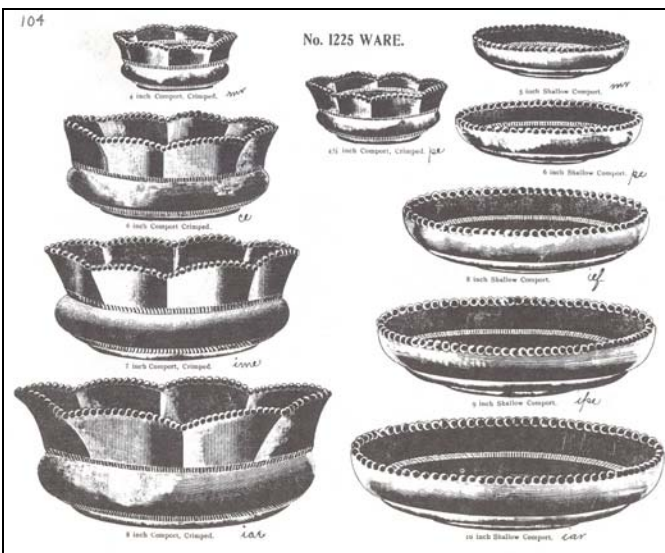

Vogel 4, Page 104



Vogel 4, Page 108



Vogel 4, Page 109



Vogel 4, Page 110

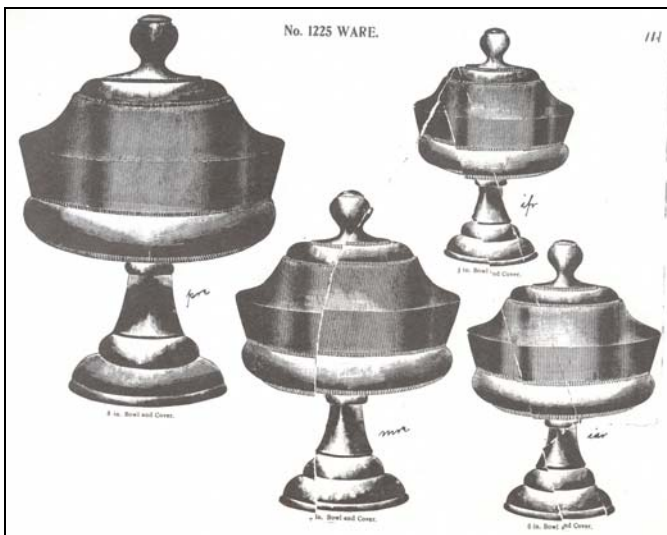

Vogel 4, Page 111

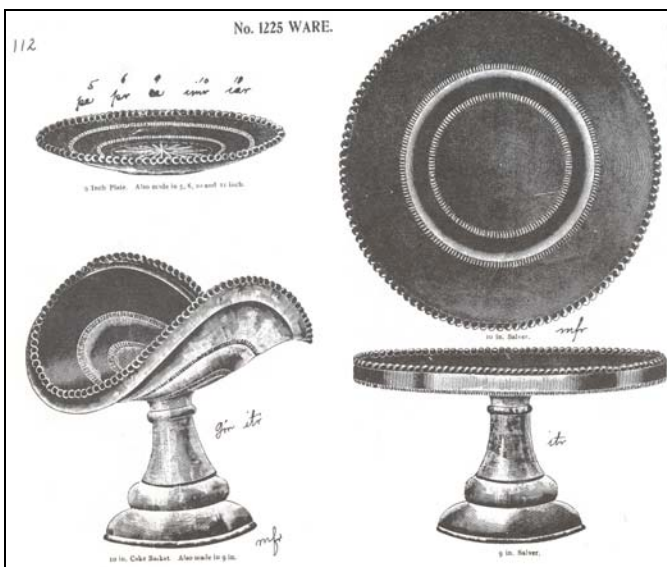

Vogel 4, Page 112

Looking at the production list of 115 items, points of interest are listed below.

1. 42 bowls covering regular, crimped, shallow, square, oval, covered and footed
2. five sizes of plates
3. four pieces of stemware
4. an individual decanter
5. pitchers and tankards in at least five sizes
6. four crushed fruit, footed and unfooted
7. three sizes of cake plates
8. four bulbous and one cylinder salt and pepper
9. an individual salt and two master salts, medium and large
10. three types of stoppers for the oils: drop, pressed and cut
11. a toy set

The list of production items were compiled from several Price Lists over the course of the production life of the pattern. These lists are not always consistent in how they describe an item so that it is possible that some items are duplicated in the list. Not all items have been shown in known company catalogs.

1225 Production

1. cream
2. sugar and cover
3. spoon
4. butter and cover
5. comport, 4"

6. comport, 4 ½"
7. comport , 6"
8. comport, 7"
9. comport, 8"
10. comport, 4", crimped
11. comport, 4 ½", crimped
12. comport, 6", crimped
13. comport, 7", crimped
14. comport, 8", crimped
15. comport, 5", shallow
16. comport, 6", shallow
17. comport, 8", shallow
18. comport, 9", shallow
19. comport , 10", shallow
20. comport and cover, 6"
21. comport and cover, 7"
22. comport and cover, 8"
23. square dish, 4"
24. square dish, 4 ½"
25. square dish, 7"
26. square dish, 8"
27. bowl, footed, 5"
28. bowl, footed, 6"
29. bowl, footed, 7"
30. bowl, footed 8"
31. crushed fruit, notched cover, 7"
32. crushed fruit, notched cover, 8"
33. crushed fruit, footed, notched cover 7"
34. crushed fruit, footed, notched cover 8"
35. oval dish, 7"
36. oval dish, 9"
37. oval dish, 10"
38. oval dish, 12"
39. bowl, footed, crimped, 5"
40. bowl, footed, crimped, 6"
41. bowl, footed, crimped, 7"
42. bowl, footed, crimped, 8"
43. bowl, footed, shallow, 6"
44. bowl, footed, shallow, 8"
45. bowl, footed, shallow 9"
46. bowl, footed, shallow, 10"
47. bowl, footed and cover, 5"
48. bowl, footed and cover, 6"
49. bowl, footed and cover, 7"
50. bowl, footed and cover, 8"
51. salver, 8"
52. salver, 9"
53. salver, 10"
54. fruit (cake) basket, 9"
55. fruit (cake) basket, 10"
56. sherbet
57. sherbet plate
58. mustard and cover
59. celery, tall
60. pickle tray, 6"
61. oblong dish, 8"
62. tumbler, 8 ½ oz.
63. tumbler, flared, stuck handle
64. mug, pressed handle
65. pitcher, stuck handle, ½ gal.
66. tankard, stuck handle, ½ gal.
67. pitcher, stuck handle, qt.
68. tankard, stuck handle, qt.
69. tankard, cream, stuck handle, pt.
70. tankard, cream, stuck handle, ½ pt.
71. tankard, cream, stuck handle, ½ pt., No. 2
72. toothpick
73. water bottle
74. individual decanter
75. salt and pepper, No. 1, medium, P.T.
76. salt and pepper, No. 2, P.T. or N.T. (same as No. 1, just different top)
77. salt and pepper, No. 3, P.T. or N.T. (same as No. 1, just different top)
78. salt and pepper, No. 4, large, P.T. or #43 T (same as No. 1, just different top)
79. salt and pepper (cylinder), C.C., N.T., #2S., or #3 S
80. individual salt
81. table salt, medium
82. table salt, large
83. handled jelly, 5"
84. handled jelly, 3 corner, crimped, 5"
85. drop stopper, oil, 4 oz.
86. pressed stopper, oil, 4 oz.
87. cut stopper, oil 4 oz.
88. drop stopper, oil, 6 oz.
89. pressed stopper, oil, 6 oz.
90. cut stopper, oil, 6 oz.
91. hotel molasses can, E.M. top, 7 oz.
92. molasses can, Pat. N.T., 13 oz.
93. molasses can, O.K. top, 13 oz. (same as number 92 – different top)
94. plate, 5"
95. plate, 6"
96. plate, 9"
97. plate, 10"
98. plate, 11"
99. cordial, ¾ oz.
100. wine, 2 oz.
101. wine, 2 1/2 oz.
102. claret, 5 oz.
103. bon bon, No. 1
104. bon bon, No. 2
105. bon bon, No. 3
106. cheese plate and cover, 9"

- 107. individual cream, stuck handle
- 108. individual sugar
- 109. hotel cream, stuck handle
- 110. hotel sugar
- 111. spoon tray
- 112. toy cream, stuck handle
- 113. toy sugar and cover
- 114. toy spoon
- 115. toy butter and cover

References 1225

- 1. Early Heisey Catalog (1900) p.43 - 49
- 2. Heisey Price List (1898) p.20 - 25
- 3. Heisey Price List #60 (1902) p.34 - 39, 102
- 4. Heisey Price List #100 (1903) p.82 – 85
- 5. Heisey Catalog #50 (1905) p.99
- 6. Heisey Price List #120 (1906) p.133 – 136
- 7. Heisey Price List #142 (1908) p.166 – 169
- 8. Heisey Catalog #56 (1909) p.150
- 9. Heisey Price List #209 (1929) p. 25, plates
- 10. Heisey News Aug. 1972, p.2, 1225 Pattern
- 11. Heisey News Oct. 1976, p.9, Mixed Patterns
- 12. Heisey News Jan. 1977, p. 5, 1225 Tumbler
- 13. Heisey News Jan. 1981, p.16, Ad for 1225
- 14. Heisey News Aug. 1982, p.4, 1225 Little Things
- 15. Heisey News June 1986, p. 4, Chronology 1897 – 1903
- 16. Heisey News April 1988, p.4, 1225 Pattern
- 17. Heisey News. Oct. 1993, p.10, 1220 Pattern
- 18. Heisey News Aug. 2005, p.26, 1225 Oval Dishes
- 19. Vogel Book 1 p.99, Book 4, p.102 – 112 ♦

**2010 HCA BENEFIT AUCTION
GUIDELINES**

(Continued from page 12)

- 6. The owner agrees to accept all responsibility for providing merchantable title for all glass sold.
- 7. HCA agrees to provide settlement in full for glass sold not later than fifteen (15) days after the completed auction. All monies received from the sale will be held in and expenditures will be paid from the HCA auction escrow account.

8. Glassware for the Benefit Auction will be accepted at any time prior to January 15 of the auction year.

9. The owner is responsible for delivery of the glass to the National Heisey Museum. HCA accepts responsibility for the glass when received at the Museum, except any glass damaged in shipment will be referred back to the shipper and owner.

10. Glass damaged or lost while in the possession of HCA prior to the sale will be valued by a qualified appraiser or appraiser selected by HCA and the owner will be paid on this basis, less commission.

11. In the event no bid is received on a lot, that lot becomes a donation to HCA. The minimum mail bid on a lot will be \$15 with a minimum opening bid of \$5. The minimum opening bid on a lot will be \$5. The minimum incremental bid increase will be \$2.50.

12. The auction committee is authorized to reject any glass not deemed acceptable for sale in accordance with HCA standards, plus any glass, as determined by the auction committee, not made by A. H. Heisey & Company or not made by another manufacturer using Heisey moulds. These rejected items may be returned to the owner if they desire, at their expense. If the owner does not want the item(s) returned or refuses to pay for shipping, the item(s) become the property of HCA.

13. The maximum number of lots to be sold at the Benefit Auction will be determined by the auction committee.

14. The auction committee will generally catalog glassware for the Benefit Auction in the order it is received at the Museum. The committee reserves the right to place lots in a different order if it determines it will improve the auction.

Approved by the HCA Board of Directors (Executive Committee) on July 25, 2009 ♦

HEISEY GOES TO THE FAIR

Geri Pinion

Every year that I have been in Ventura County, I have thought about displaying some of my Heisey collection at the county fair. But every year time would get away from me and I would miss the deadline to reserve a case. Well this year I called before the deadline and was told "I am sorry but all the cases have been reserved. But I can put you on the waiting list. You will be number 12." I said, "Yes, please put me on the waiting list" thinking there was no way I would get a call that a case was available. I just wrote it off and would hope for next year and call earlier. On July 26, 2009, I went to my Heisey study club (Heisey Club of California) meeting and left my cell phone at home. When I returned home there was a message that a case was available and they would hold it until I returned the call. Of course, I returned the call and was told the case was a 42" case. I only had a week to decide what to display and how to decorate it. I called my friend in Thousand Oaks and told her that I was entering the fair and could she be of some help. She said "Sure, what can I do. This will be a lot of fun." She did an information sheet with information about HCC and HCA. I got ready some of the all color brochures from HCA.

Some of the rules for displaying are: When you started your collection, the oldest piece in your collection, identification of each piece, and no thumbtacks.

I called the display supervisor to find out what the dimensions of the case were and he said why don't you come in and I will show you the case and you can measure it. Well the display area is actually only 39 inches. I went to my local fabric store and purchased some Heisey blue fabric to line the case and stopped at Michaels and bought place cards for identification of the pieces.

The Saturday before the fair opened was set up day. My friend from Thousand Oaks came down the hill to help and we got it set up and

left. Before I left, I asked if exhibitors were allowed in for free to see the displays and was told no. But, I checked their website to see if they put up a list of winners and found that I had won second place. Pretty good for a first time. The first place winner was displaying only shot glasses and they were not old. If anyone is interested in what I had on display you can email me at jgpurr@gmail.com for pictures or visit the HCC website and go to spotlight.



Geri's Prize Winning Display at the Ventura County Fair

August 17, 2009 was the day that exhibitors were allowed to take down there displays. All of the information about HCC & HCA was gone. Hopefully it will help both of us to get new members. HCC is on the web at www.heiseyclubca.org. ♦

1020 PHYLLIS JUG

Walter Ludwig



This unusual water jug showed up at Convention this year. It looks just like its offspring the 1020 Phyllis creamer that is shown next to it. The jug is marked but no one could remember ever having seen this item before. Convention always has a few surprises. ♦



FOR YOUR TABLE



On Every
Piece



*Delicate
shimmering
reflections
play from
stem and bowl,
lending
added enchantment
and grace
to the table
set with
Heisey  Glassware*

*At the better stores
or write
A.H. HEISEY & CO.
Dept. H50 Newark, Ohio.*

From House & Garden, July 1923
Showing Items with 163 Monticello Etch
3477 Isaly's 12 ounce handled and footed ice tea, 4164 Gallager jug, and 3312 Gayoso goblet

Study Club Directory

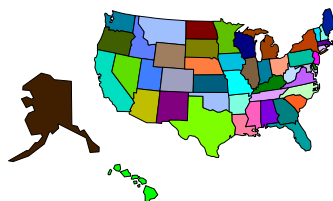

Interested in joining a study club? You will have the opportunity to meet fellow collectors and HCA members and learn more about your favorite glassware. If your club is not listed or you need to make corrections to your listing, please contact the Museum.

STUDY CLUB	MEET WHEN?	WHERE?	Email/Web Site	CONTACT
#4 Central Illinois Heisey Collectors Club	Four times a year	Members' homes or restaurants		Joyce Deany (815) 432-4310
#5 Bay State Heisey Collectors Club	2 nd Tuesday of each month except July, Aug., and Dec.	Whole Foods Community Rm, Bedford, MA	spescatore@houghton.com	Stephen Pescatore (978) 256-5418
#7 Dayton Area Heisey Collectors Club	3 rd Tues. of the month Sept. to May, 6:30 p.m.	Huber Heights Library	LH937@aol.com	Joe Harner (937) 372-0852
#8 Heisey Heritage Society <i>NJ, Eastern PA and DE areas</i>	Four times per year	Members' homes	craigkratochvil@aol.com	Craig Kratochvil (973) 962-4004
#13 Heisey Club of California	4th Sunday every month, 12:30	Members' homes	herbet@sbcglobal.net www.heiseyclubca.org	Norval Heisey (818)-349-0945
#14 Northern Illinois Heisey Club	Four times a year	Members' homes	niheisey@comcast.net	Jeff Morrow (630) 833-4644
#15 Heisey Collectors Club of Michigan	Every six weeks, August to May	Members' homes	kilgoredesigns@att.net	Sue E. Kilgore (269)-345-3990
#16 Heisey Collectors of Texas	2 nd Sat. of every odd month except May 1 st Sat., 1 p.m.	Members' homes	sanddollars97@tx.rr.com www.heiseycollectorsoftexas.org	Greg Freeman (817)-545-5889
#19 Heisey Collectors of the Rochester Area	10 meetings per year: Sunday, 2:30 p.m.	Members' homes	seo2@aol.com	Sharon Orienter (585) 288-8076
#20 Buckeye Heisey Collectors Club <i>Newark, OH area</i>	September to May, 4th Monday	Members' homes or the Museum	Theflyingmaher@webtv.net	Michael Maher (740) 763-4256
#22 Northwest Heisey Collectors	First Saturday of the month	Members' homes	bahama50@hotmail.com	Deborah de Jong (425) 868-0457
#25 Heisey 76'ers <i>Columbus, OH area</i>	Once a month, September to May	Members' homes	ldburg48@aol.com	Colleen Burgess (614) 882-1884
#31 Nassau Long Island Heisey Club	Generally every other month	Members' homes		Babs Kent (516) 228-8274
#32 Dairyland Heisey Club	Once every two months	Members' homes		Ray K. Courtneage (414) 962-9747
#33 Golden Gate Heisey Collectors Club <i>Northern California</i>	Quarterly	Members' homes		Russ Nicholas (916) 515-8558
#36 Heisey Club of Southern MA	April, June, September, December			Maria Martell (508) 833-0633
#38 North Carolina Heisey Study Group	6 meetings per year: Jan.; March, May, July, Sept., Nov.	Replacements Ltd Greensboro, NC	Nchsg@yahoo.com www.northcarolinaheiseystudygroup.org	Karen Taylo (252) 637-9985
#39 Florida Heisey Collectors Club	4 times per year: January – February-March-April	Westchester Country Club Boyton Beach, FL	Shirley400@aol.com	Everett Dunbar (772)-337-1558
#42 Gulf Coast Heisey Club of Florida	Nov., Jan. and March; 2 nd Thursday 11:00 am	Members' homes		Jack Grenzebach (727)-391-5784
#43 Tri-State Heisey Study Club <i>OH, IN, MI</i>	1 st Sat. every 3 rd month	Members' homes	Maxwellm@cktech.biz	Mike Maxwell (260) 925-3484
#45 Hoosier Heisey Club	Four times a year	Warren Library, Indianapolis, IN		J. David Litsey, (317) 872-7800
#48 Dixieland Heisey Study Club	Odd number months, 2 nd Saturday night	Members' homes	www.dixielandheisey.org	Craig German (770) 967-8733
#49 Great Plains Heisey Club	March, May, July, September, and November	Members' homes	cameron_mg@mchsi.com www.greatplainsheiseyclub.org	Mary Cameron (515) 292-3743
#50 Northwoods Heisey Club of Minnesota	Four times a year	Members' homes	wheise@comcast.net	Bob Heise (952)-831-9335
#51 Heisey Club of Northeast Florida	Feb., May, Aug., and Nov. 2 nd Thursday	Avonlea Antique Mall, Jacksonville	Clasyglas2@aol.com	Barb Bartlett (904) 280-0450
#52 Northern Virginia Heisey Study Club	Monthly, Sept. – May	Members' homes	rreopell@verizon.net	Russ Reopell (703) 250-6117

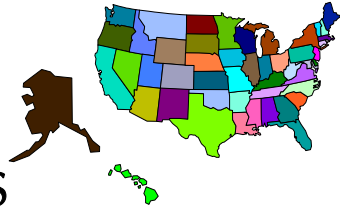

CLUB NOTES

Buckeye Heisey Collectors Club
Michael Maher

During Convention this year, the Buckeye Heisey Club again sponsored a very successful raffle with proceeds going to HCA. The lucky winners were:

- 1st place, Durward Vogel – 1260 Winged Scroll Emerald pitcher.
- 2nd place, Robert Loch – 160 Locket on Chain crystal compote
- 3rd place, Lori Kratochvil – 1184 Yeoman Sahara cream and sugar.
- 4th place, Sue Kilgore – 1506 Provincial violet vase.



Heisey Collectors of California
Geri Pinon

Eleven members of the Heisey Club of California made the trip to Escondido for our August study club meeting. Don and Carolin Nelson were our wonderful hosts. Geri Pinon wins kudos for traveling the longest distance. Don and Carolin provided us with a great lunch of sandwiches, salad, veggies, and fresh lemonade.

At the business part of our meeting we decided to start e-mailing the members of the HCA board, in color, the Pony Express newsletter which we receive via e-mail every month. Thanks to Martha's wonderful job.

Our program this month was on Ivorina and Ivorina Verde which was made by the A. H. Heisey & Company from 1896 to 1905. Some of the examples were in the patterns 1200 Cut Block which was introduced in 1896 and 1220 Punt Band which was introduced in 1220, and many more. The Ivorina and Ivorina Verde was also known as custard glass which was made by a number of different

companies. We checked some of the pieces with a black light and found that they had the Heisey glow. After a wonderful choice for desert which consisted of ice cream, homemade cookies, and brownies we had show and tell. Some of the items were a covered puff box with the Windsor cutting, triangle ashtray in crystal, and a 1255 Pineapple and Fan pickle in a beautiful silver holder.

The raffle was won by Geri Pinon and was a divided 1567 Plantation relish with an unknown cutting. ♦

Nothwoods Heisey Club of Minnesota
Ann M. Moll

Twelve members and a guest attended our August 29 meeting of the Northwoods Heisey Club of Minnesota. It was held at the home of Ann Moll. Carole Olsen, our newly elected president, called the meeting to order. A letter from HCA President Sue Kilgore acknowledging our contribution of \$1000 to the Endowment Fund and Operating Fund of HCA was shared with the group.

Club members were generous in bringing some pieces of Heisey, identified by pattern and color, to be on display at the Edina Senior Center until mid-November. The Center is pleased to house the collection. We are hopeful of acquiring some new members.

Carole Olsen gave a concise report of the 2009 Heisey Collectors of America Convention.

Information about the 30th Upper Midwest Glass and Pottery Show/Sale was shared, the dates being Saturday, October 31 and Sunday, November 1 at the Bloomington Armory, beginning at ten o'clock. Bob and Bev Heise will set up an informational table about the Northwoods Heisey Club to be manned by club members. The Heises will also host the Sunday, November 1 meeting.

Other attempts of increasing membership were mentioned. Cards with the club's information could be printed and shared at antique shows, such as the Gold Rush in Rochester, Minnesota. Bob Heise will investigate the printing of such cards. We learned that security prevents the sharing of information of a national member, for a possible contact, who may wish to join our club.

After the adjournment of the meeting, Susan Hurt, our guest, shared a piece of her inherited Heisey. The etching on the piece was identifies as 451 LaFayette. The piece showed a damsel with a handkerchief, a rooster, a man on horseback and an old fashioned boat. It was one of several chintz type etchings that Heisey produced at the time. The diamond H was located on the foot.

JoAnn Christenson presented a program about Emil Krall, describing his artistry as a glass engraver. JoAnn generously gave each of us an extensive written history about his life and photos of his work.

The following pieces were shared by the Heises: Moongleam 419 Sussex soda (1925-1946), 1401 Empress dolphin footed ice tub with a silver plated handle (1930-1938), 1252 Twist bon bon, Individual bonbon in Moongleam (1928-1937), crystal 5072 Rose Stem sherbet with 515 Heisey Rose etch (1949-1957).

Within days of our meeting, we learned of the death of Odell Johnson, age 92. He was a kind and gentle man who loved to tell jokes and stories. Odell is survived by his wife, Virginia, also a club member. He will be missed!

We welcome Susan Hurt to our organization as a member, who joined the day of our August meeting.

Mollie Campbell generously presented a delicious cake which was enjoyed by members. ♦

Advertising Guidelines:

Advertising: Ads may be mailed to: HCA Advertising, 169 W. Church St., Newark, OH 43055; faxed to (740) 345-9638; or e-mailed to curator@HeiseyMuseum.org. Whenever possible, please e-mail your ad. Include your MasterCard or VISA number and expiration date for billing purposes, or send a check. All ads must be prepaid. When mailed or faxed, ads should be typed or printed on white paper with dark ink. Please double space. Ads that are entered in a vertical column format may contain a maximum of 65 characters per line, including spaces & punctuation.

Classified: 20 cents per word (members), 30 cents per word (non-members), \$1.50 min., 1/8 page limit. Personal ads 1/8 page limit. Abbreviations & initials count as words.

Display Ads:	member	nonmember
1/8 page (12 lines)	\$ 20	\$ 30
1/4 page (25 lines)	\$ 40	\$ 60

1/2 page (60 lines, horizontal or vertical)	\$ 80	\$120
Full page (120 lines)	\$160	\$240

A charge of \$1.60 will be added for each additional line.

1/2 page: 4 1/2" high by 7 1/2" wide or 9" high by 3 1/2" wide
Full page: 9" high by 7 1/2" wide

Ad copy must be received by the first of the month prior to publication. Reproductions (i.e., Heisey by Imperial) must be indicated. Heisey News accepts no further liability. In the event of a typographical error, the incorrect portion of the ad will be run in the following issue, but HEISEY NEWS assumes no further liability.

Abbreviations: DF = Dolphin Foot NO = Narrow Optic
DO = Diamond Optic SO = Spiral & Saturn Optic
MO = Medium Optic WO = Wide Optic

Classified Ads

REAL HEISEY IN THE GIFT SHOP

All crystal and all prices are each unless noted.

Supply changes daily. Please contact the Gift Shop before placing an order.

Item	Price
134 Trident 2 lt candlestiks, silver overlay, pr	\$40
300 Peerless shot glass, H (2 each)	10
337 Touraine wine, H (2 each)	10
341 Puritan individual salt (4)	8
393 Narrow Flute individual salt tub	12
394 Narrow Flute salted nut, H	10
475 Narrow Flute/Rim salted nut, plain bottom H	15
500 Octagon tray, 6", Moongleam	10
1183 Revere individual salt (3 each)	10
1184 Yeoman cocktail	10
1184 Yeoman goblet, Flamingo	20
1205 Fancy Loop wine	18
1401 Empress individual nut, floral cut	12
1401 Empress individual sugar, Moongleam	15
1401 Empress individual sugar, H Sahara	15
1405 Ipswich sherbet (2 each)	10
1503 Crystolite 1 light candlesticks, pr	20
1503 1/4 Crystolite square candleblocks, pr	25
3362 Charter Oak finger bowl, blue and yellow stain	10
3480 Koors cocktail, Moongleam ft	10
3480 Koors soda, 8 oz with Wheeling "Pheasant on Stump" in gold, Flamingo (4 each)	15

NEW IN THE GIFT SHOP

Reprint of Catalog and Price List No. 31,
September, 1950 \$12.95
Heisey Placemats (produced by Bay State Heisey Club)
\$14 each or 2 for \$25
Heisey Notecards, 12 cards each with a different Heisey
etching plus envelopes \$12



Dealer Directory

Maximum 6 lines/12 months/\$35 MEMBERS ONLY

Contact the Editor to place your ad!



<p>KIM & PAM CARLISLE SHOWS & MAILORDERS ONLY 28220 Lamong Rd. Dept. H Sheridan, IN 46069 Glass Cleaning Services Available (317) 758- 5767 kcarlisl@worldnet.att.net</p>	<p>SHIRLEY EUGENIA DUNBAR Heisey a Specialty—Mail Order, Shows, Appraisals EMAIL: shirley400@aol.com PO Box 8344, Port St. Lucie, FL 34952 Oct-May (772) 337-1558 PO Box 222, Naples, ME 04055 May-Oct (207) 647-5652</p>	<p>SUM OF LIFE Elaine Husted: 610-469-1243 Traveling through eastern PA Call, stop in, be a buyer or a browser!! E-mail: 1classycat@comcast.net</p>
<p>ALL HEISEY AUCTION Consignments Welcome Apple Tree Auction Center 1616 W. Church, Newark, OH 43055 (740) 344-4282</p>	<p>MOUNDBUILDERS SECOND GENERATION Barbara and Richard Bartlett Heisey Exclusively! 1-904-280-0450 PO Box 1931, Ponte Vedra Beach, FL 32082 Toll Free 1-888-434-7397(HEISEYS) EMAIL: CLASYGLAS2@AOL.COM</p>	<p>EAGLES REST ANTIQUES Buying Heisey, China & Pottery Carl and Mary Evans 62 Fieldpoint Rd., Heath, OH 43056 (740) 522-2035</p>
<p>PAULA & JEFF MORROW Elegant Glassware and American Dinnerware 126 Clinton Avenue Elmhurst, IL 60126 (630) 833-4644 mor-fab@comcast.net</p>	<p>H & R DIAMOND H Helen & Bob Rarey 1450 White Ash Dr. Columbus, OH 43204 (614) 279-0390 after 5:30</p>	<p>CRYSTAL LADY Bill, Joann & Marcie Hagerty Specializing in elegant depression glassware 1817 Vinton St., Omaha, NE 68108 Shop (402) 341-0643 or Home (402) 391-6730 Email: ejhagerty@aol.com website:www.crystalladyantiques.co</p>
<p>REALMS IN GLASS Roy Eggert Heisey Custom Stained Glass 9423 Saddlebrook Ct, Frederick, MD 21701 301-260-0234 roy54@hughes.net</p>	<p>GRECIAN BORDER (GREEK KEY) By Petros Z. Mantarakis The definitive guide on Greek Key (#433) with photos and detailed descriptions of all pieces. Now available at Amazon.com Website: www.pzmworks@yahoo.com</p>	<p>PATTON HOUSE ANTIQUES Specializing in Glass*Heisey*Cambridge*Fostoria*Duncan* Factory Antique Mall, Verona, VA off I-81 Exit 227 Antiquers Mall, Booth 81, Rt. 29 N., Charlottesville, VA The Daniels, Box 547, Louisa, VA 23093 (540) 967-1181</p>
<p>C&J ANTIQUES Cole & Jean Miesner Box 45, 72 Whig St. Newark Valley, NY 13811 (607) 642-9905</p>	<p>SIBYLS OF WILMINGTON Sibyl & Ned Lavengood at Castle Corner Antiques 555 Castle St. Wilmington, NC (910) 264-9597 or Sibylsantiques@bellsouth.net</p>	<p>FRAN'S FANCY FINDS Fran & Jack Grenzsbach 10534 Valencia Rd., Seminole, FL 33772-7511 (727) 391-5184 SHOWS MAIL ORDERS</p>
<p>The American Bell Association P.O. Box 19443 Indianapolis, IN 46219-0443 www.americanbell.org m</p>	<p>PASTICHE ANTIQUES at Preston's Antique Gaslight Village US 12, Allen, MI 49227 Elegant Glass and Other Fine Antiques pasticheantiques@gmail.com</p>	<p>WILLEY'S ANTIQUES & MUSEUM Specializing in Heisey 11110 Cannon Rd., Frazeyburg, OH 43822 16 miles east of Newark, OH (740) 828-2557</p>
<p>CHARLES & MILDRED FISHER Heisey animals and Heisey By Imperial animals 1607 Dayton Rd, Newark, OH 43055 Cfisher08@roadrunner.com (740) 281-3104</p>	<p>MARSH'S ANTIQUES Dick and Virginia Marsh 4532 Newton Road Newark, OH 43055 swamp@alink.com (740) 366-5608</p>	<p>MOONGLEAM ANTIQUES Heisey Glassware & American Art Pottery John Woytowicz and Peter Rivard 70 Pleasant St., Gardiner, ME 04345 (207) 582-9048 E-mail: jmwpwr@aol.com</p>
<p>ROBERT M. LOCH Voting Member HCA and NWHC Pacific Interstate Glassware Co. PO BOX 469 Custer, WA 98240 360-366-3166</p>	<p>CRESTONE MANOR UNIQUES Harold & Loleta Hammontree 3317 Crestone Circle, Chattanooga, TN 37411 423-629-1274 hammonl@bellsouth.net Heisey Only</p>	<p>APPLE VALLEY COLLECTIBLES Richard & Marilyn Garnett – Owners Shows/ Mail Order (845) 691-8799 Email: diamondH95@aol.com</p>
<p>DOWNSTAIRS AT FELTON ANTIQUES 100B Felton St, Waltham, MA 02453 781-894-2223 info@feltonstreetantiques.com GLASSWARE, POTTERY, EPHEMERA, STERLING, FURNITURE FROM EVERY DECADE!</p>	<p>WM GLASS Bill & Mary Barker 400 Nantucket Ave., Pickerington, OH 43147 (740) 927-0918 mcbarker@embarqmail.com Heisey Only</p>	<p>WATERSEDGE ANTIQUES Norene & Don Walzer Shows & Mail Order 25089 Riverwalk Drive Leesburg, FL 34748 (352) 314-8975 dnnwalzer@embarqmail.com</p>
<p>JERRY'S ANTIQUES Shows Only Glassware and Other Fine Collectables PO Box 4485, Davenport, IA 52808 563-340-1871 jerrysantiques@mchsi.com</p>	<p>ONCE AND FUTURE ANTIQUES Susan & Stephen Pescatore 9 Donna Rd. Chelmsford, MA 01824 (978) 256-5418 Heisey and Elegant Glass</p>	<p>BOB & MARY KREIMER Specializing in Heisey Glass 7044 SW 116th Loop, Ocala, FL 34476 (352) 873-8306 email: rkreimer@earthlink.net. Shows and Mail Orders Only</p>
<p>J & L TREASURES Specializing in Heisey, Cambridge, Fostoria, Tiffin, Morgantown, etc Linda Kilburn, PO Box 1257, Burlington, CT 860-673-4088 jltreasures@comcast.net</p>	<p>Charlene Bowman Shows Only Heisey – Cambridge – Fostoria - Morgantown P.O Box 287, Clarksville, OH 45113 937-289-2114 twoclbs@aol.com</p>	<p>YELLOW BRICK ROAD ANTIQUES Jean Will Leavenworth, KS 66048 (913) 682-4831 Specializing in Heisey and Elegant Glassware Shows and Estate Sales</p>
<p>Just in Time Antique Mini Mall 29 North Third St Newark, OH 43055 Heisey in Stock 740-349-0001 ntleblanc@aol.com</p>	<p><i>Your Ad Could be Here</i></p>	<p><i>Your Ad Could be Here</i></p>

When Renewing Your Membership

Help ensure the future of your Museum. When you renew your membership at one of the levels below, any amount beyond the regular Associate dues goes into the Endowment Fund.

<i>Individual Contributing, one person in household</i>	<i>\$50</i>
<i>Joint Contributing, two people in one household</i>	<i>\$60</i>
<i>Family Contributing, parents and children under 18</i>	<i>\$75</i>
<i>Patron</i>	<i>\$125</i>
<i>Sponsor</i>	<i>\$250</i>
<i>Benefactor</i>	<i>\$500</i>

Visit The
National
Heisey
Glass
Museum



Come at your leisure to enjoy more than 4,800 pieces of glassware produced by A.H. Heisey and Company from 1896-1957. Hundreds of patterns are featured in all production colors. Rare and experimental items are included as well.

Facilities are air-conditioned and handicapped-accessible. Hours are 10:00 a.m. to 4:00 p.m. Tuesday through Saturday, 1:00 to 4:00 p.m. Sunday (except Jan. and Feb.). Members are admitted free, regular admission is \$4. Office hours are 8:00 a.m. to 4:30 p.m. weekdays.

Membership Renewal Notice: Check the date above your name and address on the mailing label. This is your expiration date. If it reads 10-10-09, make sure your dues are paid soon in order to receive next month's issue of *Heisey News*.

Contact the HCA Administrative Office at (740) 345-2932 for more information. The Endowment Committee wishes to thank those who have become Endowment Members and all of the individuals and study clubs that have so generously supported the HCA Endowment Fund. All members who have supported the fund are recognized each year in the February issue of the Newsletter. Your support will make the Museum self-sustaining in the years to come. Thank You all! ♦

Shipping & Handling Fees for Outside US

Additional shipping charges are required for members living outside the U.S. Current rates are Canada, \$22; for other countries, contact the Museum. Rates are subject to change at any time due to rate changes made by the US Postal Service. To verify current rates, call (740) 345-2932 or E-mail business@HeiseyMuseum.org



Periodical Postage

Paid at the Post Office
In Newark, OH 43055
Publication # 00986
POSTMASTER SEND FORM 3579 TO:
HCA
169 W. Church St.
Newark, OH 43055

To: _____

Museum Volunteers for August 2009

Charlene Bowman
Chuck & Amy Jo Jones
Frank Kuhlmann
Don & Pat Moore
Phyllis McClain
Sharon Orienter
Ginny Priest
Dick & Marilyn Smith
Dave & Mary Ann Spahr
Karen Taylo
Charlie Wade