

# HEISEY NEWS

The Official Publication of Heisey Collectors of America, Inc.

Volume XXXVIII No. 8

August 2009

ISSN 0731-8014

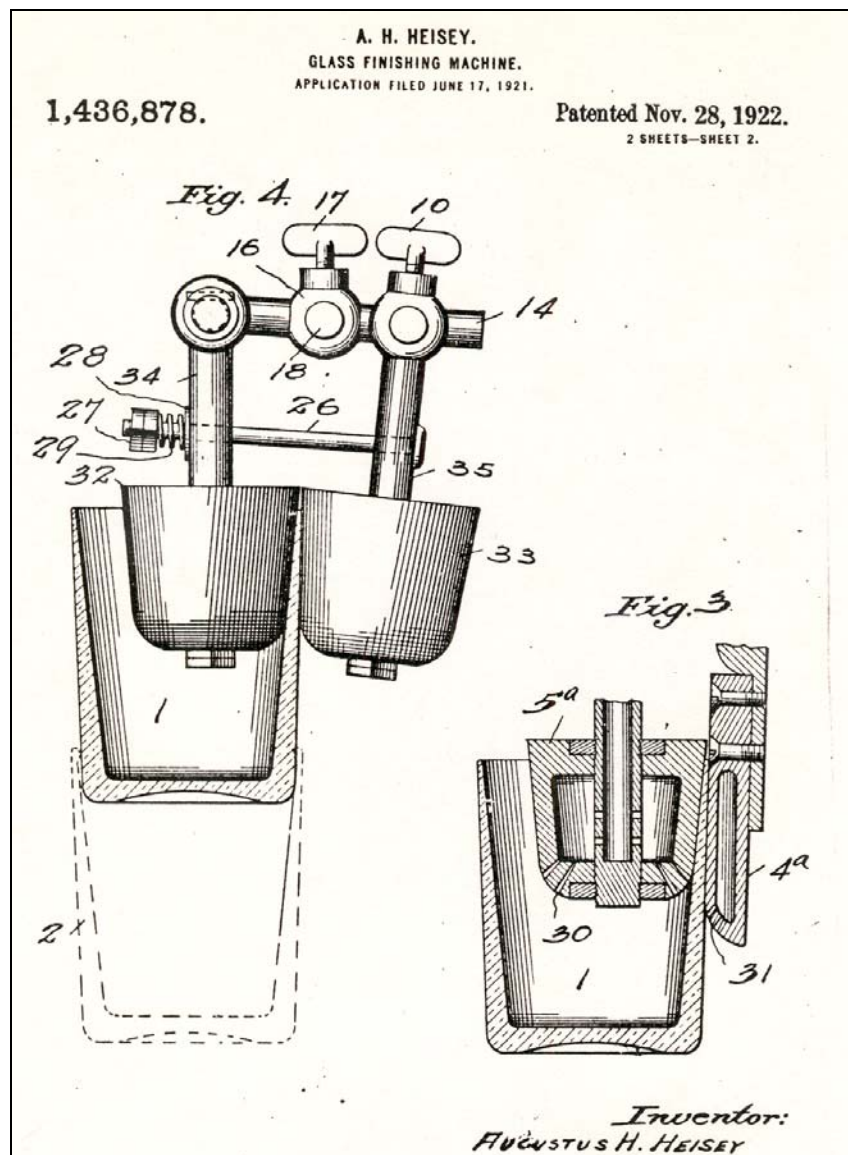

Patent 1,436,878 – Illustration 2

A.H. Heisey's Last Utility Patent

Read Part Six of the Story of A. H. Heisey & Company Utility Patents on Page 5

## HEISEY NEWS

Heisey Collectors of America, Inc.

169 West Church Street

Newark, Ohio 43055

Phone 740-345-2932 Fax 740-345-9638

Web Site: [www.heiseyMuseum.org](http://www.heiseyMuseum.org)

All Rights Reserved 2009

ISSN 0731-8014

### Staff and Phone Extensions

Curator, Walter Ludwig, [curator@heiseyMuseum.org](mailto:curator@heiseyMuseum.org), Ext. 4

Clerks, Justin Church, Amanda McDonald, Micki Wareham

[membership@heiseyMuseum.org](mailto:membership@heiseyMuseum.org), Ext. 1

Gift Shop, Ext. 5

### HCA Board of Directors:

**President**, Sue Kilgore – Kalamazoo, MI, 269-345-3990 –

[hcapresident@heiseyMuseum.org](mailto:hcapresident@heiseyMuseum.org)

**Vice-President**, Karen Taylo – New Bern, NC, 252-637-9985

**Secretary**, Charlene Bowman – Clarksville, OH, 937-289-2114

**Treasurer**, Sharon Orienter – Rochester, NY, 585-288-8076

Member-at-Large, Dave Spahr - Xenia, OH, 937-372-7166

Bryan Baker - Fairfax Station, VA, 703-250-6117

Sid Edwards – Tallassee, AL, 334-283-4663

Tom Files – Kansas City, MO, 816-468-7087

Amy Jo Jones - Beavercreek, OH, 937-426-1567

Bob Kreimer – Ocala, FL, 352-873-8306

Robert Loch – Custer, WA, 360-366-3166

Jack Metcalf – Utica, OH, 740-892-2664

HEISEY NEWS is published and printed monthly, by Heisey Collectors of America, Inc. (HCA). Periodical postage paid at Newark. Subscription is limited to HCA members. First class mailing is available for an extra \$20.00, due with payment of membership. If you are having difficulty receiving your Newsletter, please contact the HCA Administrative Office Monday through Friday 8:30 a.m. - 4:30 p.m.

The opinions expressed in articles in HEISEY NEWS are those of the authors and not necessarily those of the organization. The Editorial Staff reserves the right to edit, with or without the consent of the author or to refuse any material submitted for publication.

### Back Issues

Back Issues available from files are \$3.00 per issue plus shipping and handling

### Advertising

Ads may be mailed to: HCA Advertising, 169 W. Church St., Newark, OH 43055; faxed to (740) 345-9638; or e-mailed to [curator@HeiseyMuseum.org](mailto:curator@HeiseyMuseum.org). Whenever possible, please e-mail your ad. Always include your MasterCard or Visa number and expiration date. When mailed or faxed, ads should be typed or printed on white paper with dark ink. Camera ready ads are accepted, but must follow line specifications outlined at the beginning of the advertising section. Ads containing reproductions will not knowingly be accepted unless clearly stated (e.g. Heisey by Imperial, etc.). HEISEY NEWS accepts no further liability. In the event of a typographical error, the incorrect portion of the ad will be run in the following issue, but HEISEY NEWS assumes no further liability. See advertising section for rates and deadlines.

### Museum

Heisey Collectors of America, Inc., a non-profit corporation (tax-exempt status), owns and operates The National Heisey Glass Museum in Veterans Park, 6th and Church Streets, Newark, Ohio. Open year round, Tuesday through Saturday 10:00 a.m. – 4:00 p.m., Sunday 1:00 – 4:00 p.m. (except Jan. and Feb.), closed holidays. Other hours by appointment. Members admitted free.

### Identification

HCA will attempt to identify unknown glass items. Send a color photograph, measurements, and a self-addressed, stamped envelope to the attention of the Curator. Other arrangements should be made in advance with the Museum staff. Please keep in mind that the Museum cannot appraise items. Identification is free to members, non-members \$5.00 per item.

### Membership

To join Heisey Collectors of America or to renew your membership, contact the HCA Administrative Office Monday through Friday 8:00 a.m. - 4:30 p.m. Eastern Time. Associate dues are \$30.00 plus \$5.00 for each additional household member. Voting members pay an additional one-time fee of \$25.00. Please consider supporting the Endowment Fund by joining at one of the levels listed on the back page.

### Museum Gift Shop

There is always someone in the Gift Shop during the Museum's hours of operation to help answer questions or take orders. When ordering by phone, please have a credit card ready. When ordering by mail, please be sure to include appropriate charges such as shipping and sales tax. Please note that the HCA member discount does not apply to original Heisey or special project items.

### Shipping and Receiving

Delivery is made much easier when we have a complete street address, not a PO Box. We prefer to use UPS. If you have not received a package, please call the Administrative Office to confirm it was sent. We will assist you in tracing it. If your package arrives damaged, please contact your local UPS representative. We insure everything.

### Donations and Loans to the Museum

If you would like to make a donation to the Museum or have questions regarding items on loan, contact the Curator. HCA reserves the right to accept or refuse items based on current holdings.

## HEISEY CALENDAR OF EVENTS

### 2009

Percy and Vivian Moore Memorial Weekend	October 2-3
2009 Fifth Heisey Select Auction	October 3
December Holiday Open House	December 5

### Table of Contents

Utility Patents Associated with A.H. Heisey & Company (Part 6), Walter Ludwig	FC & 5-12
Heisey Calendar of Events	2
Message from the President, Sue Kilgore	3-4
Curator's Report, Walter Ludwig	4
HCA Welcomes New Members for June 2009	4
385 Grid and Square, Joe Lokay	13
398 Hopewell, Joe Lokay	13-14
1218 Simplicity and 1219 Simplicity with Star, Joe Lokay	15-16
1216 Plain and 1217 Star Bottom Nappies, Joe Lokay	16-17
Museum Contributions January 2009 – June 2009, Walter Ludwig	17-19
January – June 2009 Museum Monetary Contributions, Walter Ludwig	19-20
Heisey Select Auction – October 3, 2009, Dave Spahr	20
HCA Wish List, Sharon Orienter	20
Heisey Trade Advertisement 1950	21
Heisey Glass Museum Playing Cards, Order Form (Green Deck)	22
Study Club Directory	23
Club Notes	24-25
Advertising Guidelines	25
Classified Ads	25-26
Lariat Advertisement, 1944	26
Dealer Directory	27
Museum Volunteers for May 2009	BC

## MESSAGE FROM THE PRESIDENT

Sue Kilgore

It is a great honor for me to serve this organization as its president. It seems that I have been in love with Heisey all my life, but, actually, it has only been since I married Dan thirty-eight years ago. We gave this love to our daughters and are now passing it on to our grandchildren. Some of you might remember that we brought our daughters to Convention with us for several years. They were given \$50 each to see how much Heisey they could buy in their chosen patterns – 4044 New Era and 1469 Ridgeleigh. By the end of Convention we were having them buy our Heisey for us – something about cute young girls!!! Hopefully they will join us again soon at Convention. Needless to say, Heisey has also brought us great friends and lots of fun times.

As your new president, I have high hopes for our organization and Museum. Years ago, we all came together to “save” our collections by buying the original Heisey molds and having a place to store them. Then, we needed to “grow” our Museum and we accomplished that as well. Back then our membership was over 3000. We are now around half of that.

Now we need to help our membership grow again. We all know that our membership has been “downsized”. I would love to see our study clubs “spread the word” about Heisey. How wonderful for them to set up a display at a local museum, make a presentation to a club, or set up at an antique show or in an antique mall showcase. Not only could people learn about Heisey, its quality and beauty, but they may be able to make new friends and have them become new members of HCA. I would like to see this be an annual event for each of the clubs.

Our new website will help HCA get more exposure as well. Please be sure to visit the site and spread its information to your friends. It is unclear what might spark someone’s interest to

join our organization, but visiting our new site and seeing the beautiful pictures, might get someone excited about collecting Heisey.

Our Convention this year was so well organized. I want to thank Judy & Mary Ann for doing a really wonderful job as co-chairs and we are pleased to report that they will repeat the process for next year. (Can we all believe that it is going to 2010 soon – not I.) The number attending was close to the same as last year but we had quite a few new people and we are always glad to see new faces. We hope they had a great time and are now more excited about Heisey than ever.

Please make your plans to join us for the Moore weekend in Newark the first weekend in October. The weekend will be lots of fun and, of course, cooler weather for Ohio. We will have the select auction on Saturday afternoon preceded by a flea market in front of the Museum. Please come to see what you “might not have” in your collection yet.

Your Board of Directors is committed to keeping our Museum and organization strong and healthy. Remember, your board is everywhere – Florida, North Carolina, Missouri, Michigan, Washington, New York, Alabama, Virginia and Ohio, of course. We are here to listen and learn from all of you. Please consider what you can do to help us and contact a member or me today. Please make sure that you help HCA to remain a great group of devoted people promoting a wonderful Museum full of gorgeous glass.

I want to thank our past president, Bryan Baker, for all that he accomplished for HCA for the three years that he held the office. It is not an easy job trying to make everything run smoothly and keep everyone involved and happy. Bryan made great strides in giving the Museum a more orderly arrangement, updating the website, and getting our glass into the Governor’s Mansion! Great work, Bryan, we can never thank you enough and we are still relying on you to continue promoting HCA and Heisey.

Until next month, I hope that the rest of your summer is all that you want it to be and that all your Heisey hunting “dreams come true”. Be safe and have fun.

Sue Kilgore ♦

## CURATOR’S REPORT

Walter Ludwig

July has been a great month here in Newark with the temperature behaving very nicely. We have had some really wonderful summer days and nights. Some are complaining because we have not had much rain, but I am thankful because it keeps the lawn from getting totally away from me.

The after-Convention jobs are gradually getting the attention that they need. There are just so many things that have to be taken care of. I apologize for your July 2009 Newsletter coming to you so tardily, but with Convention coming so late in the month and the need to get the Convention information published, I was not able to get that issue in the mail until July 8. This issue should be much timelier.

We received so many wonderful items for the Museum during Convention and they are acknowledged starting on page 17. At the Convention show, I was also able to purchase a great many examples of Heisey cuttings that we did not have represented in our collection. It is just this type of item that is needed to have a truly representative collection of the production of A.H. Heisey & Company.

During Convention, in honor of the Convention theme of Heisey Etchings our King House dining room table was a truly elegant display of some of the best of Heisey’s production. The table was set with items with 447 Empress etching in Moongleam. A great many accessory pieces were included in the display. The set will remain on view through the month of August, so if you did not see it during Convention, make an effort to stop in at the Museum for this special

treat. I am sharing with you two pictures of this display – I just wish you could see these pictures in color.

Before you know it the summer will be over, while you are on vacation do drop in on a never before visited antique store or mall. You never know, there could be a treasure there just waiting for you to arrive. Remember, Heisey will not find you; you have to go out and find it.



King House Dining Table Set with Moongleam 447 Empress Etch



Side Table in King House Dining Room

**HCA WELCOMES  
NEW MEMBERS  
FOR  
June 2009**

Myrle Scott, NJ

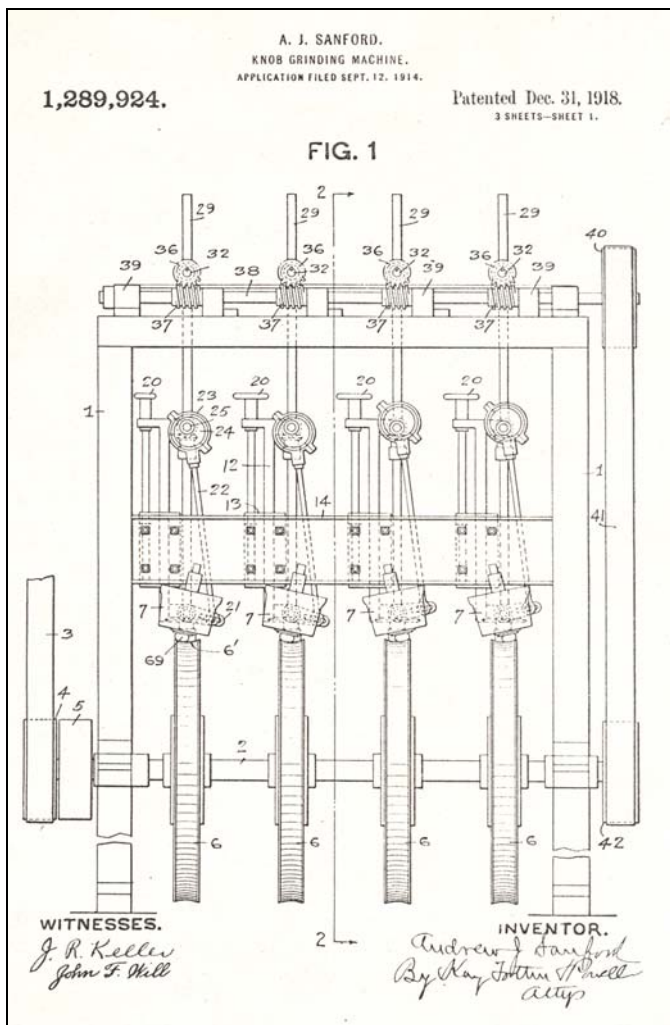

Patent 1,289,924 – Illustration 1

## UTILITY PATENTS ASSOCIATED WITH A.H. HEISEY & COMPANY (PART 6)

Walter Ludwig

The next set of utility patents was issued to A. H. Heisey & Company between 1918 and 1926. All of these patents cover aspects of the glass making process rather than the more interesting development of specific glass pieces. I will go through these a bit quicker, but I will show all of the illustrations that accompany each patent. I find they really do convey some of the feel of what it was like to be in a glass factory at this time.

Our first patent is No. 1,289,924 issued to Andrew J. Sanford and assigned to A.H. Heisey

& Company on December 31, 1918. The patent office was still catching up from the war years because this patent was originally applied for on September 12, 1914. The patent is for a Knob-Grinding Machine.

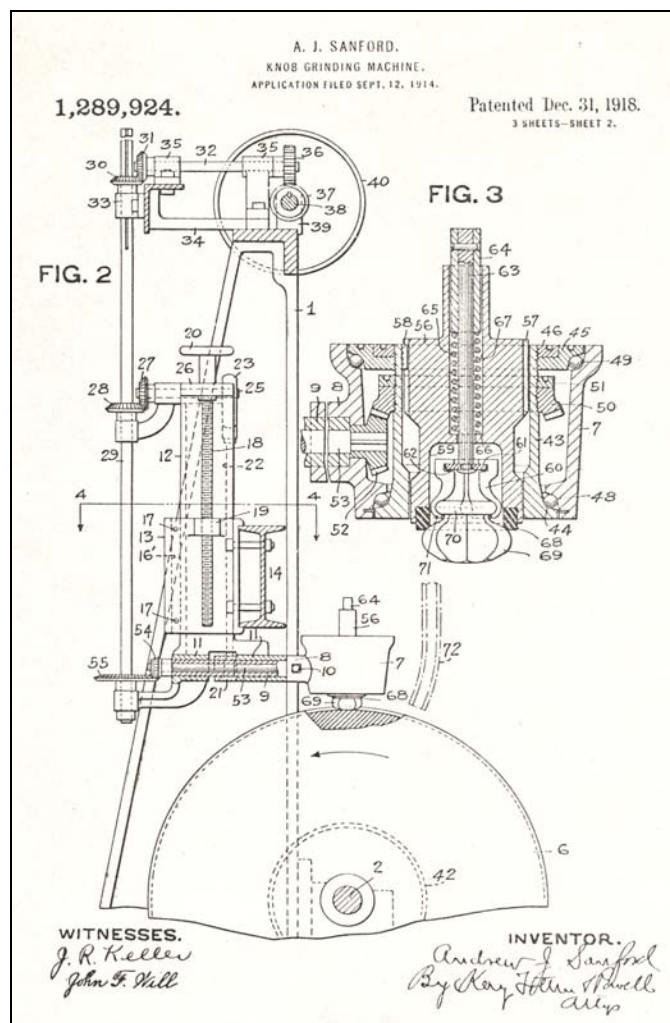

Patent 1,289,924 – Illustration 2

As the application states it "relates to a knob grinding machine or to a machine for grinding and finishing a spherical face on the top of a knob, usually the knob of a bottle or jar, but it is equally adapted for finishing the ends of door knobs and the like made of glass. The invention also contemplates forming not only a convex spherical face on objects of this character, but also forming a concave spherical face on glass articles where such form of face is desired. A further object of the invention is to provide means for operating upon a plurality of objects simultaneously. A further object is to provide

such means that by the operation thereof spherical faces of great accuracy and uniformity may be formed on the several objects."

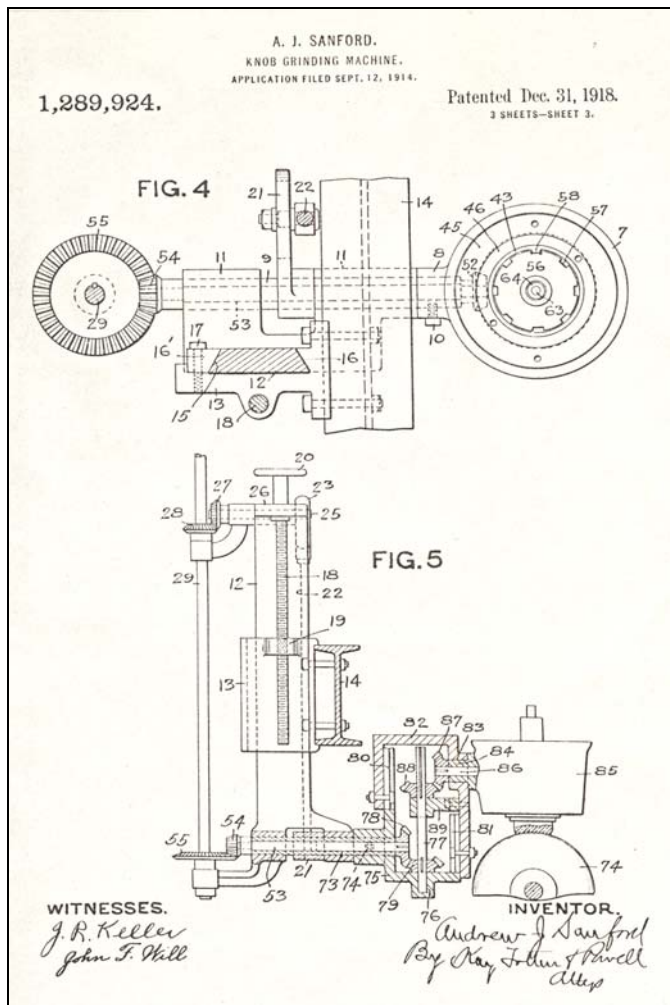

Patent 1,289,924 – Illustration 3

Given all of the lavender jars that Heisey was producing in this period, one can see where such a machine would have been well used at the Heisey factory. It was also in 1919 that Heisey produced a series of glass doorknobs and drawer pulls which would have also been produced on machines described in this patent. It is unfortunate that no records have survived telling us exactly what these doorknobs looked like but it is felt that most of them were generic designs that were produced by many different glass companies.

Our next patent was No, 1,436,825 granted on November 28, 1922 to Andrew J. Sanford. This patent was for a Glass Finishing Tool. There

was little delay on the granting of this patent since it was filed for on June 17, 1921.

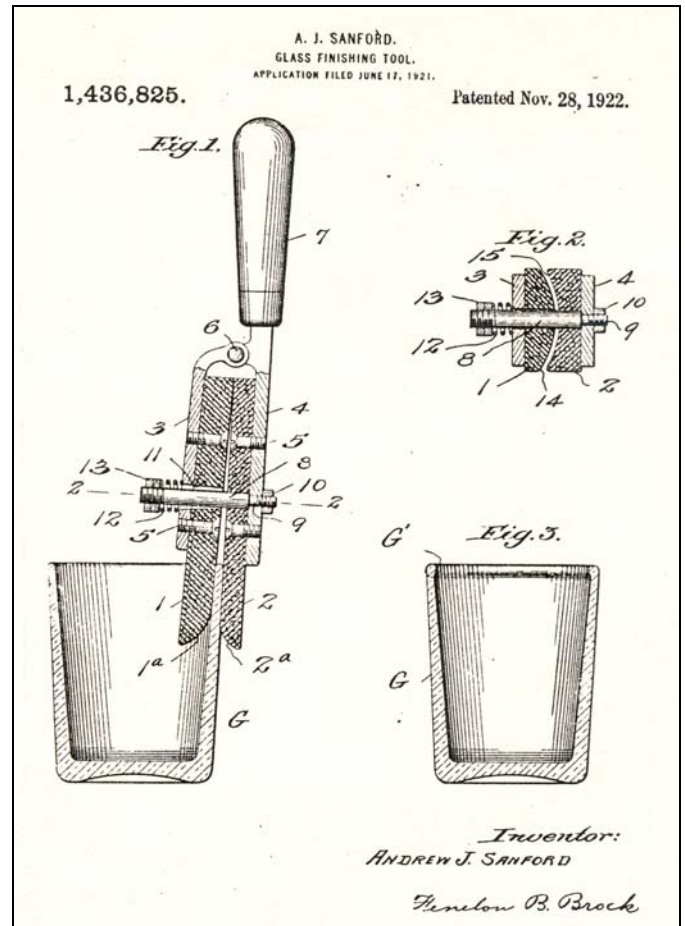

Patent 1,436,825

The description reads, "The invention relates particularly to that class of tools utilized in finishing cylindrical glassware, such as tumblers, vases, and similar articles, wherein the walls of the open end article are required to be thinned, and especially for use in eliminating the annular bend at the inner edge of tumblers formed during the process of making the tumbler.

"To this end the invention consists essentially in certain novel combinations and arrangements of parts involving a pair of shaping or squeezing fingers for co-action on the walls of the cylindrical article to be thinned, and also in certain novel features of construction wherein a resilient pressure is accomplished and proper adjustment secured for reducing the plastic walls of the glass article to the required thickness."

Granted simultaneously with patent No. 1,436,825 is patent No. 1,426,878. Both have the same application date and the same date of issuance. No. 1,426,878 however list Augustus H. Heisey as the inventor as opposed to Andrew J. Sanford. Both patents are for related Glass-Finishing Machines. Given that A.H. died on February 22, 1922, this would be the last patent that his name would appear on.

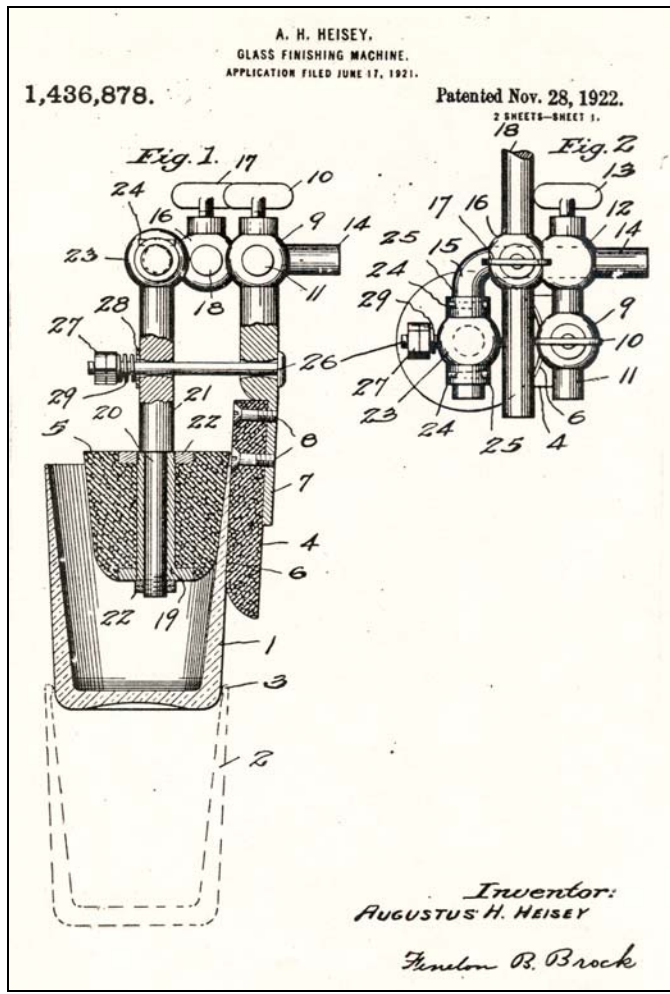

Patent 1,436,878 – Illustration 1

The defining paragraph for this patent is identical to the paragraph for No. 1,436,825 except for the substitution of the word “machines” for the word “tool” resulting in the opening line reading “The invention relates particularly to that class of machines utilized in finishing cylindrical glass ware, such as tumblers, vases, and similar articles ...”

The patent then goes on, “In the process of making the cylindrical article, such as a tumbler,

vase, etc., the glass may be either stuck on an iron punty or glass end on said punty, or the glass is caught in a snap device or holder to retain the cylinder in position for re-heating the material of the end that is to be finished or thinned out. During this process the glass article is retained in the finishing machine and thereby revolved a number of times in one direction, and then revolved an equal number of times in the reverse direction. During this movement of the glass the device of my invention is applied to the open end of the cylinder for uniformly thinning its walls and edges, and the forward and reverse movement of the cylindrical article, while in a heated condition and being operated upon by the device of my invention, prevents the heated plastic material from running together, and insures a perfect, symmetrical article.

“The manipulation of the glass cylinder and the action thereon by the device of my invention, insures the production of an acceptable and merchantable tumbler, vase, or similar article, and the machine forming the subject matter of my invention performs its functions with facility and accuracy.

“With the above ends in view the invention consists in certain novel combinations and arrangements of parts in a finishing machine as will be hereinafter more fully described and claimed.”

The combination of these two inventions meant that A.H. Heisey & Company had a great machine that would produce expertly finished tumblers and vases, probably excelling those that were produced by the competition. Illustration 2 for Patent 1,436,878 can be found on the cover of this issue.

Patent No. 1,515,793 was issued to Andrew J. Sanford and John B. Townsend assigners to A.H. Heisey & Company (a co-partnership) on November 18, 1924. The invention was for a machine for finishing glassware. On September 15, 1925, patent No. 1,554,038 was issued to the same individuals for a machine for fire

polishing and finishing glassware. These two patents deal with the same machine with the later patent having been filed on August 30, 1921, and the former one on March 27, 1922. It would seem that these patents were held up in the system for a while and that their order became reversed when it came to issuing the patent. There may have been a technical detail in patent No. 1,554,038 which held up the issuance.

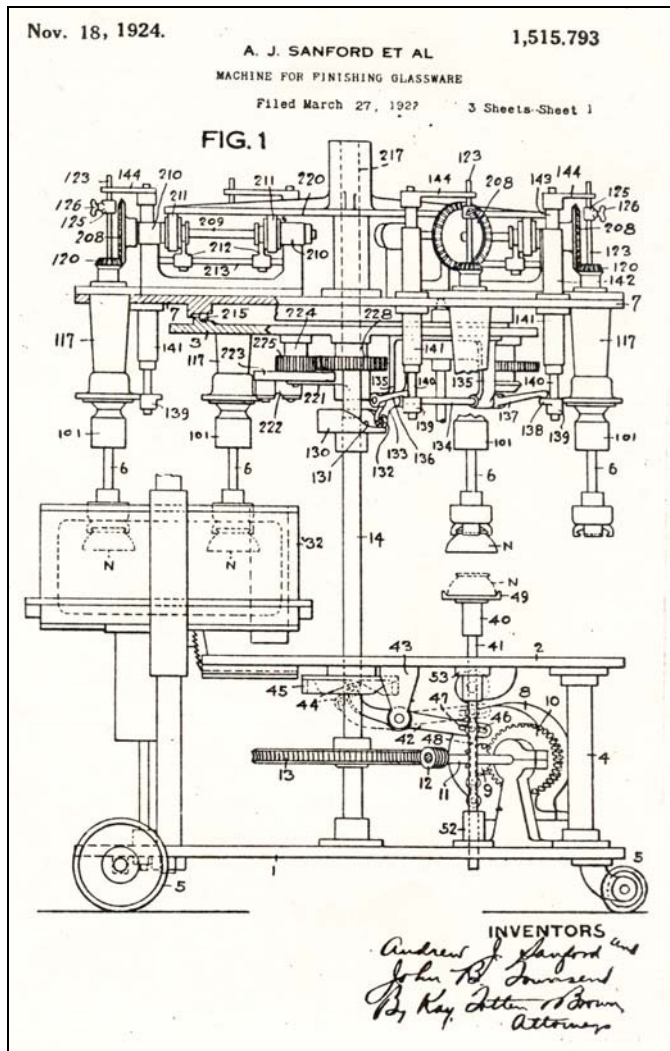

Patent 1,515,793 – Illustration 1

I will quote from No. 1,515,793 since it refers back to 1,554,038 and describes both inventions. "Our invention relates to glass finishing machines having snap devices for holding the glassware during the fire-polishing and finishing operations, and its object is to provide an automatic finishing machine having a simple and effective snap which shall operate

automatically to receive the ware to be finished, to carry the ware through the finishing operations, and finally to discharge the finished ware.

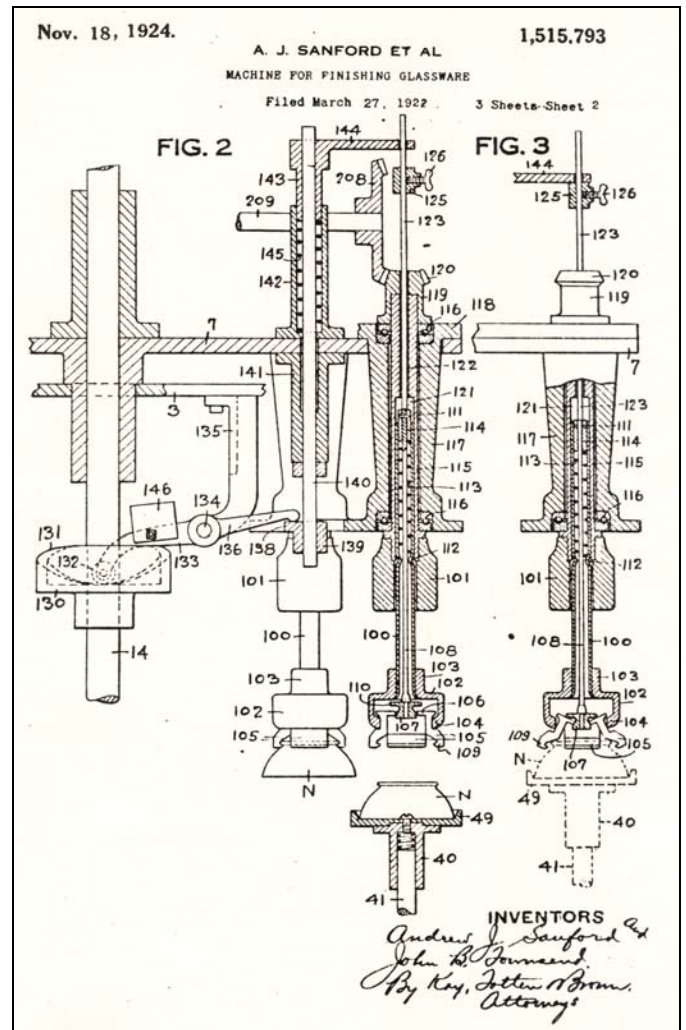

Patent 1,515,793 – Illustration 2

Our co-pending application [which became patent No. 1,554,038] ... describes and claims a machine for receiving tumblers, nappies, and other hollow glassware, carrying the ware to a series of fire-polishing glory holes, with exposure to the air between the fire-polishing operations, and then finishing and burnishing the fire-polished ware, and finally discharging the finished ware. The said co-pending application shows, as its specific means for holding and conveying the ware, a form of device in which the ware is "stuck up" upon the lower surfaces of ware holding punties and is attached to the punties by the adhesion of the soft glass. Our present invention is designed to



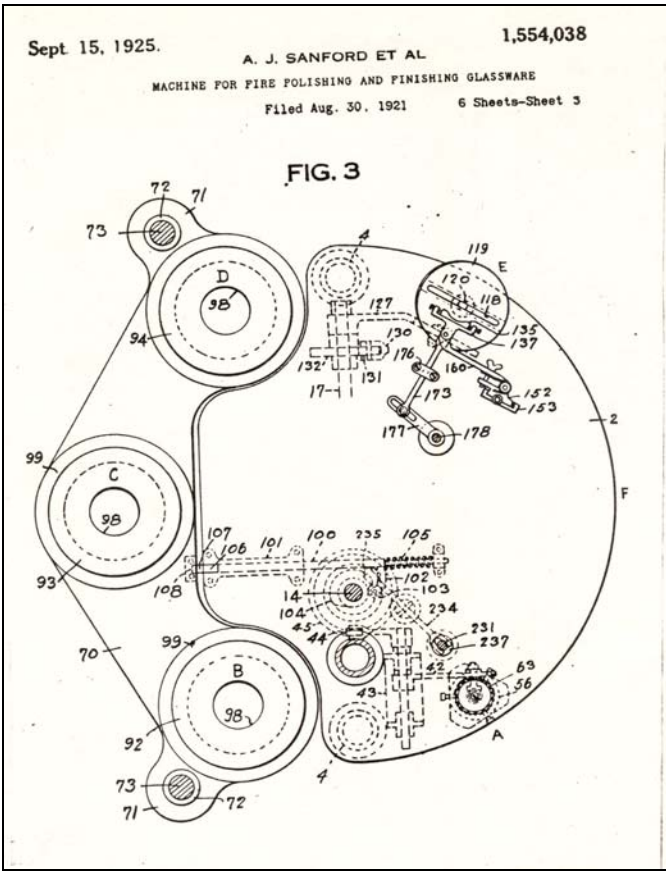

Patent 1,554,038 – Illustration 3

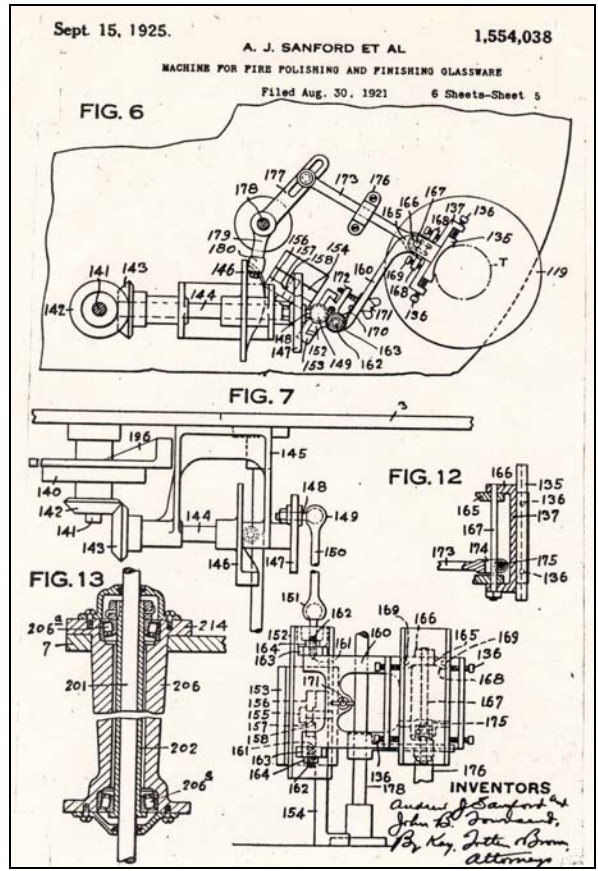

Patent 1,554,038 – Illustration 5

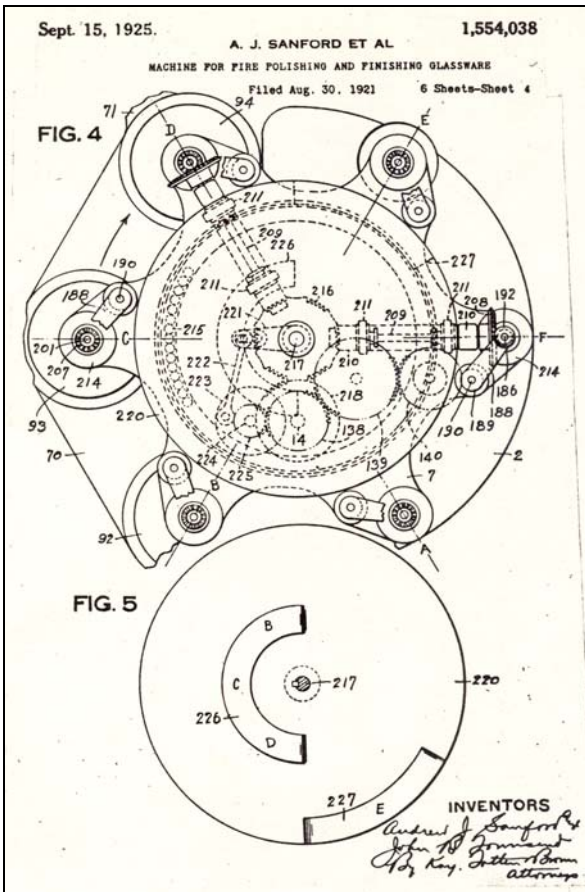

Patent 1,554,038 – Illustration 4

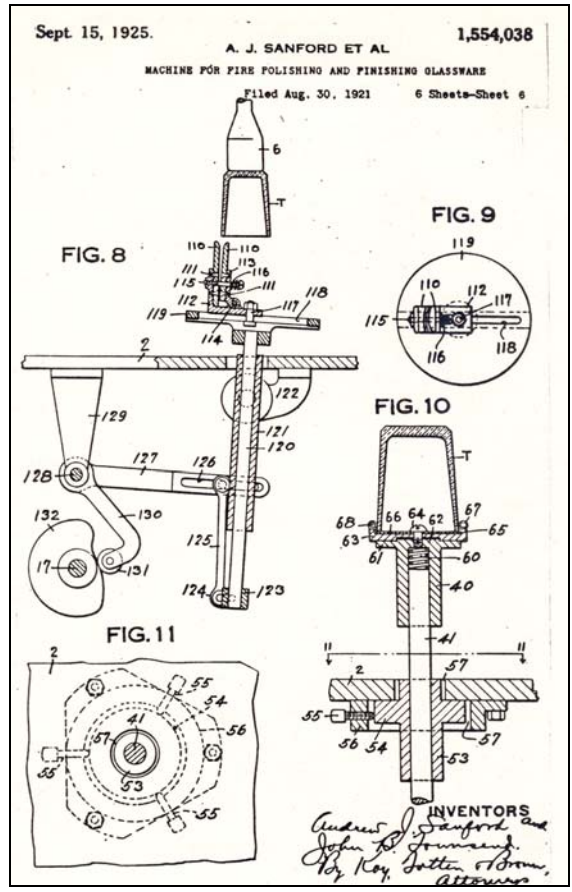

Patent 1,554,038 – Illustration 6

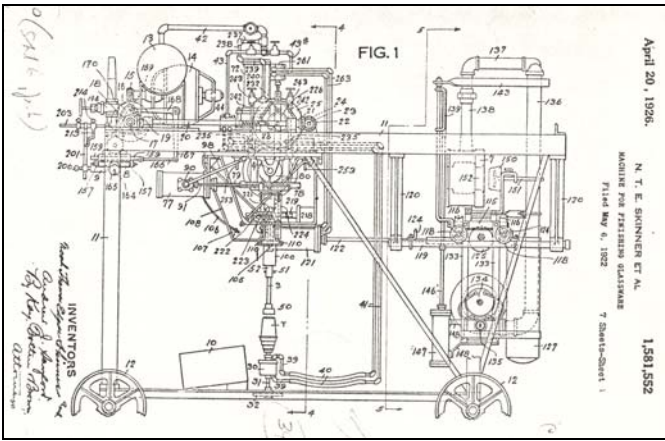

Patent 1,581,552 – Illustration 1

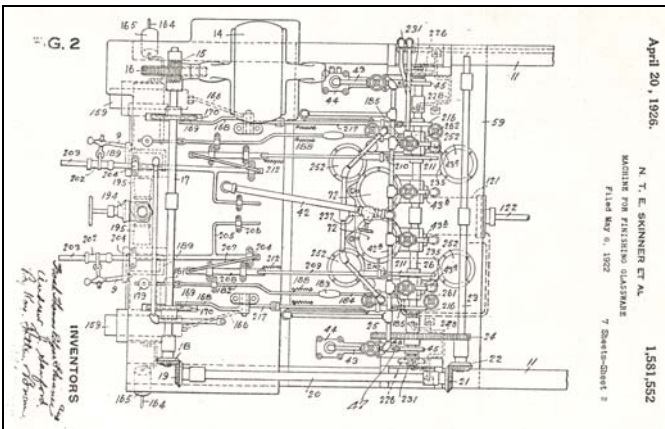

Patent 1,581,552 – Illustration 2

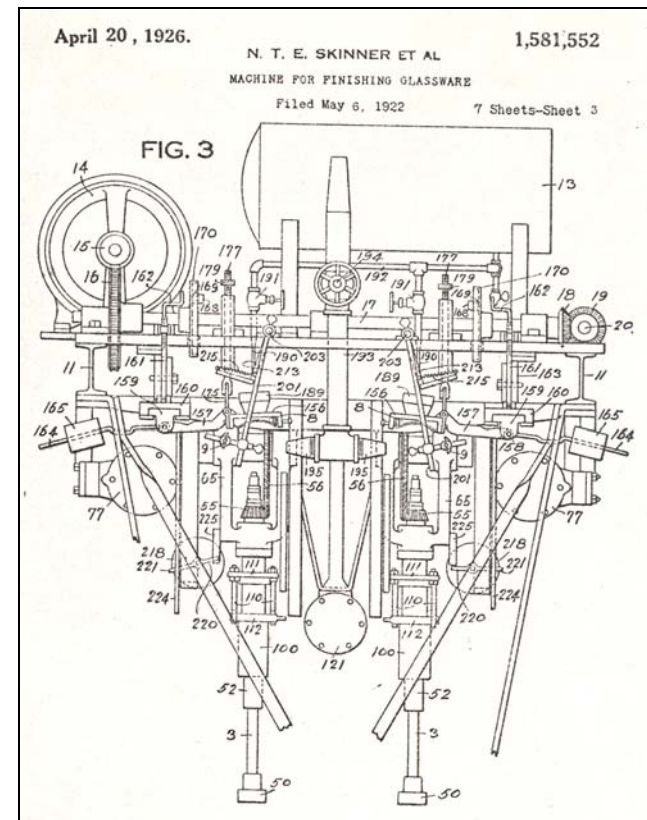

Patent 1,581,552 – Illustration 3

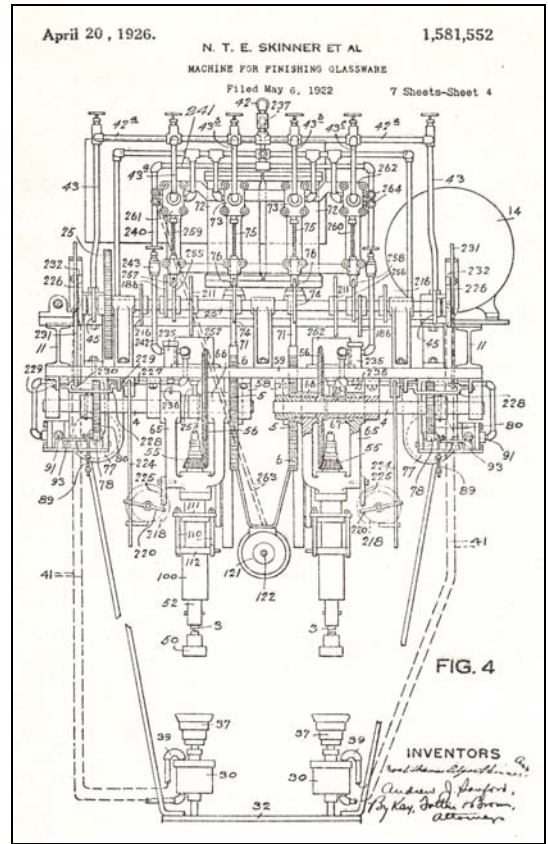

Patent 1,581,552 – Illustration 4

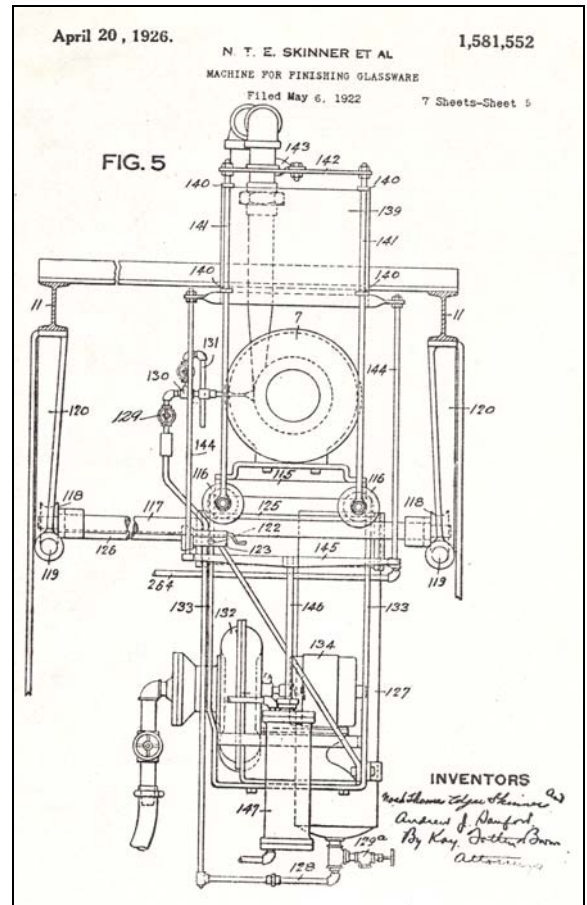

Patent 1,581,552 – Illustration 5

The final patent that we will look at in this issue is No. 1,581,552 issued on April 20, 1926, to Thomas Edgar Skinner and Andrew J. Sanford, assignors to A.H. Heisey & Company (a co-partnership). This patent is for a machine for finishing glassware.

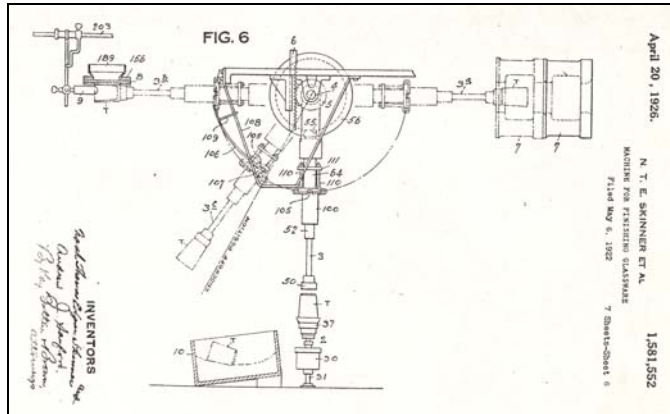

Patent 1,581,552 – Illustration 6

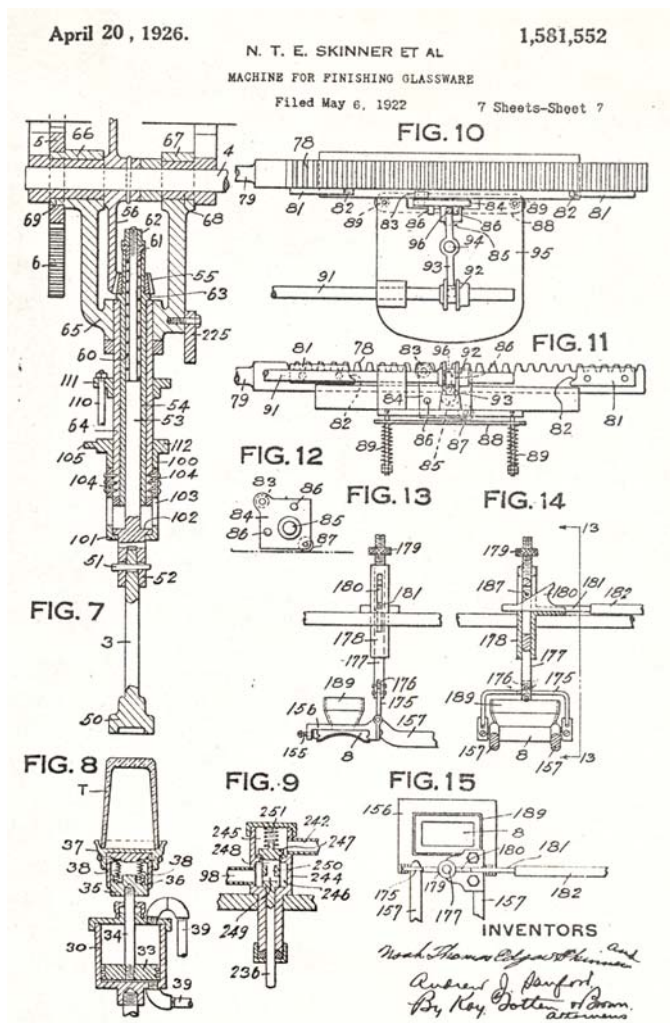

Patent 1,581,552 – Illustration 7

This seems to have been an improvement on the previous patents for glass finishing that we just covered. The description reads, “Our invention relates to machines for fire-polishing and finishing tumblers and other hollow glassware.

“The object of our invention is to provide a machine which shall perform the various operations of finishing glassware accurately and more speedily than the same work can be done by hand. To this end we provide a machine which operates to “stick-up” the tumblers or other articles upon a vertical punty, which, after it receives the ware, rocks from a vertical to a horizontal position, where the ware is enclosed in a movable glory hole to fire-polish the ware, after which the punty rocks again through 180 degrees to bring the ware into contact with buffing devices which polish the ware and restore its shape, after which the punty again descends and the ware is “knocked off” automatically.

“For the purpose of performing automatically all of the above operations we provide a series of cam-operated compressed air cylinders which impart the necessary movements to the punty and to the glory hole furnace in which the ware is fire-polished, together with additional cams for operating the buffers which finish the ware.”

This certainly sounds like the latest in technology for the 1920s. So much is being automated in this process that it obviously would reduce the number of workers needed to accomplish the task. Heisey continued to achieve its high quality product while attempting to reduce the cost of production.

This was a rather technical group of patents but they are important to see how the company was evolving to meet the production demands of the time. I find the detailed illustrations that accompany these patents fascinating.

Next month we will get back to inventions that deal directly with new forms in glassware. I think you will be able to more directly relate to those utility patents, as opposed to the technical ones in this issue. ♦



385 Tankard



385 Tumbler

## 385 Grid and Square

Joe Lokay

A. H. Heisey & Company never recognized pattern 385 which has been named Grid and Square as a formal pattern. It was first listed in Heisey Price List #148 (1909) under miscellaneous additions. The pattern was pictured in Heisey Catalog #56 (1909). In Price List #155 (1910), it was again listed under miscellaneous. It was shown in Catalog #75 (1913) under miscellaneous. The life of #385 is estimated as 1909 to 1916.

There are only two items in this pattern, the half gallon tankard and the 9 oz. tumbler. Both items are pressed and signed with the Diamond H. They were made in Crystal only.

The pattern can be described as large concave squares separated at the corners by grids of cross hatches. The glass is of high quality.

### Production

1. tumbler, 9 oz, star bottom, ground bottom
2. tankard, half gallon, stuck handle

### References

1. Heisey Price List #138 (1909), p.5  
Listed under miscellaneous additions
2. Heisey Catalog #56 (1909), p. 185
3. Heisey Price List #155 (1910), p.193

Listed under miscellaneous

4. Heisey Price List #175 (1915), p.19
5. Heisey Catalog #75 (1913), p. 9, 260
6. Heisey News, Dec. 1975, p.8, 385 Pattern
7. Heisey News, Nov. 1976, p..7, 385 Tumbler
8. Heisey News, Jan. 2005, p.13, 385 Water Set ♦

## 398 HOPEWELL

Joe Lokay

Pattern 398 is another set of nappies with a very long life. The pattern consists of eighteen nappies, nine with diameters 3 ½" to 9" and another nine shallow nappies with diameters 4" to 10". The life of the shallow nappies was 1908 to about 1935, about 28 years. The life of the regular nappies was 1908 to about 1940 for 33 years. This nappy pattern represents one of the longest life items that Heisey produced.

The design of the nappy is very simple. The plain walls curve out like a tea cup. The flat bottom is ground to insure levelness. The nappies are signed with the Diamond H. Over time, if the molds are not regularly reworked, the Diamond H will get very weak and perhaps be gone.

The shallow nappy is made by forming out the walls of the regular nappy while the glass is hot and workable. The walls are worked, keeping the same wall thickness, so that the diameter gets bigger as the height is reduced. Thus, the 4" shallow nappy came from the 3 ½" regular nappy and the 10" shallow nappy came from the 9" regular nappy. Only one mold is needed for both styles of nappies.

The name Hopewell for this pattern was assigned by early researchers. This is such a plain pattern that it is often found with various decorations, usually by companies to whom Heisey sold the undecorated blanks. I have seen nappies in this pattern with Heisey's 941 Barcelona cutting but also some very garishly decorated nappies done by Charlton of New York.

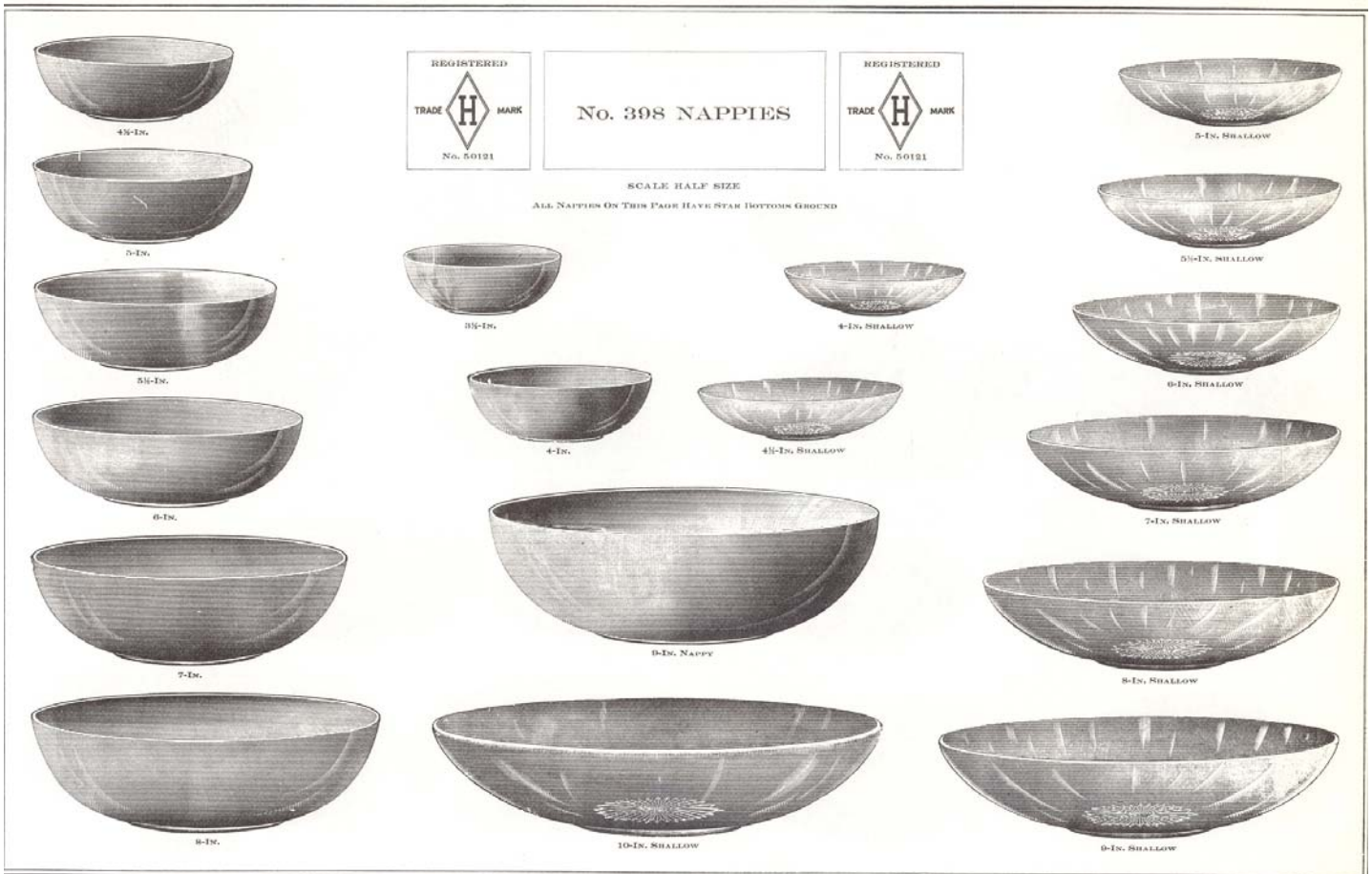

398 Hopewell Nappies – Catalog #75, page 85

**Production**

1. nappy, 3 1/2"
2. nappy, 4"
3. nappy, 4 1/2"
4. nappy, 5"
5. nappy, 5 1/2"
6. nappy, 6"
7. nappy, 7"
8. nappy, 8"
9. nappy, 9"
10. nappy, 4", shallow
11. nappy, 4 1/2", shallow
12. nappy, 5", shallow
13. nappy, 5 1/2", shallow
14. nappy, 6", shallow
15. nappy, 7", shallow
16. nappy, 8", shallow
17. nappy, 9", shallow
18. nappy, 10", shallow

**References**

1. Catalog #56 (1908), p. 154
2. Price List #155 (1911), p. 64
3. Price List #175 (1913), p. 92
4. Catalog #75 (1913), p. 85
5. Price List #179 (1917), p. 78
6. Price List #200 (1917), p. 78
7. Price List #205 (1919), p. 73
8. Catalog #100 (1920), p. 47
9. Price List #206 (1922), p. 61
10. Price List #208 (1924), p. 58
11. Catalog #102 (1924), p. 44
12. Catalog #109 (1929), p. 109
13. Price List #209 (1929), p. 23
14. Catalog #212 (1937), p. 19
15. Catalog #214 (1939), p. 19 ♦



Patterns 1216 – 1219, Catalog 75, Page 258

## 1218 SIMPLICITY AND 1219 SIMPLICITY WITH STAR PLATES

Joe Lokay

A. H. Heisey & Company produced plates in the 1218 Simplicity and 1219 Simplicity with Star patterns for about 28 years. Production started in about 1907 and ended in about 1933. Pattern 1218 consisted of seven plates ranging in diameter from 4 1/2" to 11". The design was a simple plate design with a plain circular bottom. Pattern 1219 also consisted of seven plates of the same sizes. These were the same simple plate design except the circular bottom contained the typical Heisey star. These plates were designed to go with the 1216 Plain and 1217 Star Bottom nappies. Used together,

Heisey offered them as a salad set of various sizes. The plates are signed with a diamond H.

Heisey would have had seven different molds that would have produced all of the seven different pieces in patterns 1216-1219. The switch of a bottom plate would change the mold to produce either a plain bottomed piece or a star bottomed piece. The use of a former after the item was made in the mold (where it would have looked like a nappy) would allow the item to be transformed from a nappy to a plate.

### Production

#### 1218 Simplicity

1. plate, 4 1/2"
2. plate, 5 1/2"
3. plate, 6"
4. plate, 7"

5. plate, 8"
6. plate, 9 ½"
7. plate, 11"

### 1219 Simplicity with Star

1. plate, 4 ½"
2. plate, 5 ½"
3. plate, 6"
4. plate, 7"
5. plate, 8"
6. plate, 9 ½"
7. plate, 11"

### References 1218, 1219 Plates

1. Heisey Catalog #56 (1908), p. 154
2. Heisey Price List #148 (1909), p. 8
3. Heisey Price List #155 (1910), p. 90
4. Heisey Price List #175 (1913), p. 91
5. Heisey Catalog #75 (1915), p. 258
6. Heisey Price List #179 (1917), p. 77
7. Heisey Price List #200 (1917), p. 77
8. Heisey Price List #205 (1919), p. 72
9. Heisey Catalog #100 (1920), p. 46
10. Heisey Price List #206 (1922), p. 60
11. Heisey Price List #208 (1924), p. 57
12. Heisey Catalog #102 (1924), p. 42
13. Heisey Catalog #109 (1928), p. 18
14. Heisey Price List #209 (1929), p. 24
15. Heisey Price List #210 (1933), p.56
16. Heisey News, March 1999, Dinner Plates
17. Heisey News, August 2006, Salad Sets ♦

## 1216 PLAIN AND 1217 STAR BOTTOM NAPPIES

Joe Lokay

For about ten years, from 1905 to 1915, A. H. Heisey & Company produced many different kinds and sizes of nappies. There were many patterns in which various sizes of nappies were the only pieces in the pattern. Patterns 1216 Plain and 1217 Star Bottom are nappies only patterns. Pattern 1216 covers seven nappies of sizes four to nine inches in top diameter with plain bottoms. Pattern 1217 also covers seven

nappies of sizes four to nine inches in top with star bottoms. You are given a choice of a plain or a star bottom (and thus the names that were assigned to these patterns by early researchers). The star bottom is the typical Heisey star. Following the Heisey Price Lists, 1216 and 1217 were started in 1908 and lasted to about 1930, for a production life of about 23 years.

Three salad sets of five, seven and eight inch size were offered in 1216 or 1217. Plates for the sets were from patterns 1218 and 1219. The preceding article covers these two patterns.

In 1910, a 2 ½ oz. Roman punch, a finger bowl and plate (plain or star) and a plain horseradish were added to the 1216 line. The salad sets and the finger bowl used the pattern nappies. The punch and horseradish were of plain design to match the plainness of the nappies

The design of these nappies is very simple, a tapered cylinder for the walls and a plain or star flat bottom. The bottoms were ground to insure levelness.

### Production

#### 1216 Plain

1. nappy, 4"
2. nappy, 4 ½"
3. nappy, 5"
4. nappy, 6"
5. nappy, 7"
6. nappy, 8"
7. nappy, 9"

#### 1217 Star Bottom

1. nappy, 4"
2. nappy, 4 ½"
3. nappy, 5"
4. nappy, 6"
5. nappy, 7"
6. nappy, 8"
7. nappy, 9"

## References

1. Heisey Price List #142 (1908), p. 178
2. Heisey Catalog #56 (1908), p. 154
3. Price List #148 (1909), p. 7, 8
4. Price List #155 (1910), p. 65, 194
5. Price List #175 (1913), p. 94
6. Catalog #75 (1913), p. 258
7. Price List #179 (1917), p. 79
8. Price List #200 (1918), p. 79
9. Price List #205 (1919), p. 73, 74
10. Price List #206 (1922), p. 61
11. Catalog #102 (1924), p. 45
12. Price List #208 (1924), p. 58
13. Price List #209 (1929), p. 23
14. Catalog #109 (1928), p. 26, 113
15. Heisey News, Sept. 1987, 1216 horseradish



## MUSEUM CONTRIBUTIONS JANUARY 2009 – JUNE 2009

Walter Ludwig

We want to thank all those who have contributed to the success of the Museum in the first six months of this year. The following have made contributions that greatly enhance the Museum by donating glass for the collection and for sale in our Gift Shop as well as valuable archival material. If you made a contribution and you are not listed or not listed correctly, please let someone at the Museum know so that proper recognition can be given.

### To the Collection:

**Barbara Rauck Bartlett:** 1458 Courthouse coupe plate elaborately cut and 4225 Cobel 1 pt. cocktail shaker with "Us" etch, both in memory of James "Jamie" Van Winkle, Jr.

**Christine Chaconas:** 16 Susannah puff box with 9034 St. Luke's Commandery etch.

**Marian L. Dalton:** 333 Old Glory champagne with 35 Lacy Band etch, H; 3312 Gayoso goblet with 164 Salem etch.

**Heisey Heritage Society:** 3307 Aloof cordial with 384 Iroquois etch in memory of Dr. Frank Husted

**Elaine Husted:** 363 Colonial cordial, 601 Elizabeth cordial, 1000 Carlsbad cordial, 4085 Kohinoor cordial, 5013 Shasta cordial with 926 George IV cutting all in memory of Dr. Frank Husted

**Caroline Jenson:** 1254 sherbet, low footed with conical center.

**Jack Metcalf:** 442 Maltese Cross ashtray, Flamingo H

**Tina Morgan:** 4163 Whaley beer mug, 16 oz. with Equestrian etch, in memory William H. and Betty K. Morgan

**Julia and Amelia Morrow:** 1201 Fandango pint tankard cream

**Paula and Jeff Morrow:** 341 Old Williamsburg epergnette (no candle cup) in memory of Guy Mahan.

**Northwoods Heisey Club of Minnesota:** 500 Octagon ice tub with unattributed cutting, H, in memory of Stephen A. Bergren, founding member, Northwoods Heisey Club of Minnesota.

**Sharon Orienter:** 1127 fine tooth butter pat in memory of Betty Evans

**OSU Dealers 2009:** 355 Quator mustard with cutting in memory of Dick Schwan; 394 Narrow Flute individual domino sugar tray and 2401 12 oz. Oakwood soda with 495 Polo Player etch in memory of Terry King

**Bob Rarey:** 5058 Goose Stem cordial, frosted

**Dick and Marilyn Smith:** 509 Queen Ann jelly, ftd with 941 Barcelona cutting; 585 soda, 9 oz., optic

**Dave Spahr:** 300 Peerless spooner; 1503 Crystolite shell bonbon, 7", footed

**Kyle Stache:** 300 Peerless sherbet, Flamingo, H

**Karen Taylo:** 3404 Spanish goblet with 461 Concord etch

**James T. Taylo:** Replica of Heisey 461 Banded Picket Basket currently being retail by Shannon Crystal by Godinger (Made in China)

**Durwood Vogel:** 6010 Finesse ftd juice

**Burl and Berry Whaley:** 341 Puritan nappy, 8" with cover, H, iridized

**For the Archives:**

**Paula J. Dinkel:** Heisey ephemera including reproductions of original drawings of 1567 Plantation items by Horace King.

**Adele Pardee:** Heisey ephemera including numerous original ads, stationery, pattern folders, and other material.

**Donations for the Gift shop:**

Phil and Sally Abrams

Sandra Barker

Mr. and Mrs. Gordon W. Cochran

Carolyn Crozier

Evelyn Daniel

Sandra Dyer

Joseph Harner

Amy Jo Jones

Jack Metcalf

Marcene Schafer

Dave Spahr

Charlie Wade

Jack and Maezene Walker

**Purchases from Acquisitions Fund**

352 Flat Panel knife rest

433 Greek Key crushed fruit jar, 2 qt.

1508 card case with 914 Royal Sensation cutting

1540 Lariat ftd soda, 12 oz with 999 Carolina cutting

1540 Lariat goblet with 982 Moon Gleam cutting

3320 Ritz goblet with 704 Magnolia cutting

3350 Wabash goblet with 746 Mt. Vernon cutting

3350 Wabash cocktail with 883 Royal York cutting

3408 Jamestown goblet with 985 Sheffield cutting

3420 Milwaukee pilsner

5024 Oxford ftd soda, 12 oz with 976 St. George Waterford cutting

5024 Oxford soda, 5 oz with 1055 Westminster cutting

5024 Oxford oyster cocktail, ftd with 974 Star Waterford cutting

5033 Continental wine with 948 Bouquet cutting

5077 Legionnaire goblet with 1029 Evening Star cutting

5077 Legionnaire goblet with 1035 Cornflower cutting

5089 Princess goblet with 1073 Serenade cutting

6003 Tempo champagne with 1081 Wedding Band cutting

6060 Country Club ftd soda, 12 oz with 1031 Greenbriar cutting

**Items Put on Loan:**

300 Old Williamsburg 18" candle lamp with 507 Orchid etch

1218 Simplicity plate, 5 1/2" with 1 Braid etch. H

4165 Shaw Jug, handleless, Moongleam

3307 Aloof goblet with 384 Iroquois etch

3308 Bob White goblet with 403 Chartier etch

3315 Polonaise sundae, fld with 370 Nile etch

3320 Ritz goblet with 433 Dutchess etch

3330 Hanover wine with 19 Double Loop etch

3345 Many 'n Virg champagne with 169 Biltmore etch

3397 Gascony juice, ftd, Sahara with 453 Inca etch

3409 Plymouth goblet with 457 Springtime etch

5079 Pan American claret with 518 Pan American Lei etch

6091 Cabochon goblet with 9021 Arbor V

6091 Cabochon goblet with unknown iris etch

8047 San Diego champagne with 161 Sommerset etch. H

All following items with Krall family cuttings (Willibald unless noted)

1184 Yeoman (2) cruets, 4 oz., floral cut

1401 Empress cr/sugar, floral cut

1401 Empress pickle/olive 13", floral cut

1401 Empress celery, 13", geometric cut

1401 Empress vase, 9 1/2", bird cutting

1401 Empress ice bucket/tongs, oriental cut

1489 Puritan (2) Fr. dressing bottle, floral cut

1497 Boat floral bowl, 11", geometric cut

1509 Queen Ann floral bowl, rolled edge, 12" floral cut

1509 Queen Ann floral, flared, 14" floral cut

1509 Queen Ann jelly, ftd, floral cut

1509 Queen Ann candelabra, pr, floral cut

1509 Queen Ann sandwich, ctr hdd, floral cut

1519 Waverly torte, 14", floral/geometric cut

1519 Waverly relish, 3 part, 11", oriental cut

1540 Lariat platter, 14", thistle cut

1540 Lariat bonbon, handled, oriental cut  
 3368 Albemarle goblet, floral cut  
 3368 Albemarle goblet, roses cut  
 3408 Jamestown dinner bell  
 3411 Monte Cristo goblet, geometric cut  
 4052 National tumbler, 10oz., oriental cut  
 4055 Park Lane goblet, floral cut  
 4055 Park Lane champagne, floral cut  
 4163 Whaley tankard, oriental cut  
 Steuben Tumbler, Princess Margaret cut (Anton  
 Krall) ♦

## JANUARY - JUNE 2009 MUSEUM MONETARY CONTRIBUTIONS

Walter Ludwig

If you made a contribution between January and June that does not appear on this list, or is listed incorrectly, please contact the Museum so that we may update our records and properly recognize your contribution.

### ENDOWMENT FUND DONATIONS (of \$100 or more):

Phil Abrams, \$100  
 Bay State Heisey Collectors Club, \$150  
 Buckeye Heisey Collectors Club, \$435  
 Darlene Cochran, \$500  
 Clyde Cook Jr., \$100  
 Glen G Gall, \$125  
 Great Plains Heisey Club, \$550  
 Gulf Coast Heisey Club of Florida, \$500  
 Heisey Club of California, \$1,000  
 Heisey Collectors of Rochester Area, \$800  
 Mary Hibbs, \$145  
 Edward D. Hinshaw, \$250  
 Jeffrey J Larson, \$125  
 Joseph Noll, \$500  
 National Capital Heisey Collectors Club, \$100  
 North Carolina Heisey Study Group, \$500  
 Northwest Heisey Collectors, \$300  
 Betty Lee Pease, \$135  
 Karen Taylo, \$500  
 Tri-State Heisey Study Club, \$400  
 Nancy Shore, \$150

Maezene Walker, \$125  
 Herbert Wanser, \$110

### ENDOWMENT FUND DONATIONS ( In Memory Of):

William Clifford, \$100, in memory of Bob McClain  
 Alyce Griffith, \$25, in memory of Bob McClain  
 Edward and Nan Fogler, \$35, in memory of Richard Schwan  
 Margaret Howell, \$50, in memory of Richard Schwan  
 National Capital Heisey Collectors Club, \$50, in memory of James Van Winkle, Jr.  
 National Capital Heisey Collectors Club, \$50, in memory of Jim Gartner, Jr.  
 North Carolina Heisey Study Group, \$100, in memory of Richard Schwan  
 Phil and Sally Abrams, \$100, in memory of Richard Schwan  
 Don and Norene Walzer, \$25, in memory of Richard Schwan

### OPERATING FUND DONATIONS (of \$100 or more):

Sandra Barker, \$100  
 Bay State Heisey Collectors Club, \$400  
 Buckeye Heisey Collectors Club, \$435  
 J. Sidney Edwards, \$100  
 Great Plains Heisey Club, \$550  
 Gulf Coast Heisey Club of Florida, \$500  
 Heisey Collectors Club of Michigan, \$4,612.50  
 Heisey Collectors of Texas, \$1,757  
 Elaine Husted, \$1,100  
 Sue Kilgore, \$210, money collected on yellow dress during Convention  
 Jeffrey J Larson, \$125  
 Robert M Loch, \$600  
 North Carolina Heisey Study Group, \$500  
 Northwest Heisey Collectors, \$200  
 Tri-State Heisey Study Club, \$350  
 Jean Will, \$125  
 Mary Beth Will, \$200

### HOSPITALITY DONATIONS

Betty Lee Pease, \$25  
 Gulf Coast Heisey Club of Florida, \$50  
 North Carolina Heisey Study Group, \$100

## Donations to Convention Special Auction

Phil and Sally Abrams  
Gordon and Darlene Cochran  
Dayton Area Heisey Collectors Club  
Sid and Mary Edwards  
Joe and Flo Harner  
Heisey Club of California  
Heisey Collectors of Texas  
Heisey Heritage Society  
Bob and Mary Kreimer  
Rex and Pat Lucke  
John and Trudy Mock  
Don and Pat Moore  
North Carolina Heisey Study Group  
Northern Illinois Heisey Club  
Northern Virginia Heisey Study Club  
Northwest Heisey Collectors  
Dave and Mary Ann Spahr  
James and Bobbi Taylo  
Karen Taylo  
Jack and Maezene Walker  
Herb and Betty Wanser

## Miscellaneous

W. Drescher & Associates Co., L.P.A., \$362.50



## HEISEY SELECT AUCTION - OCTOBER 3, 2009

Dave Spahr

Hope you are planning to come to Newark again this year for a wonderful **SELECT AUCTION**. It is scheduled for Saturday, October 3 and will be in the afternoon. It is a part of a wonderful Percy and Vivian Moore Weekend in Newark! We will have details on the auction and registration forms for Percy and Vivian Moore weekend in the next Newsletter.

We have selected glass from our submitted lists but have not inspected the glass as of the time that I write this. Our deadline for submission of glass is July 13 and close to the Newsletter deadline for submission of this article. We should have nearly 200 lots of clean damage-free Heisey glass for your buying enjoyment! We are also working a glass show/flea market –

hopefully folks will be setting up and selling Heisey and other glass in our Museum parking lot on Saturday morning before the auction. Please contact Michael Maher at 740-763-4256 if you are interested in setting up!

FYI, the September Newsletter will also include a listing of the Select Auction glass and other instructions, including absentee bid forms for use by those who can't make it to Newark! Hopefully, we can highlight our special pieces for auction in that issue.

Hope to see you there - please come and plan on having a great time! ◆

## HCA Wish List Sharon Orienter

Reprinting of our most popular reference book, a new exhibit about the glass factory, updating and printing of the etching book, a new flat-screen TV and DVD player, conversion of videos to DVD, wireless computer capability. What do all of the above have in common? They are all items on the HCA "wish list." Some are projects in the beginning stages some are only distant dreams, but all have been discussed or requested and would be great to accomplish.

All of these projects are certainly worthy and would enhance our ability to get our message out to the public.

Significant resources, both financial and human, are needed for these projects. In our bare-bones budget, none have been fully planned for. Some may be worked into the budget as funds allow, but we are also anticipating having to set aside funds for the replacement of the roof in the next few years, which will likely leave very little for projects.

HCA members we need your help! If you or your Study Club, or a couple of Study Clubs collaborating, would like to take on a special project on the Wish List, contact any member of the Executive Committee for more information.



Bright news for your crystal business



Moonglo

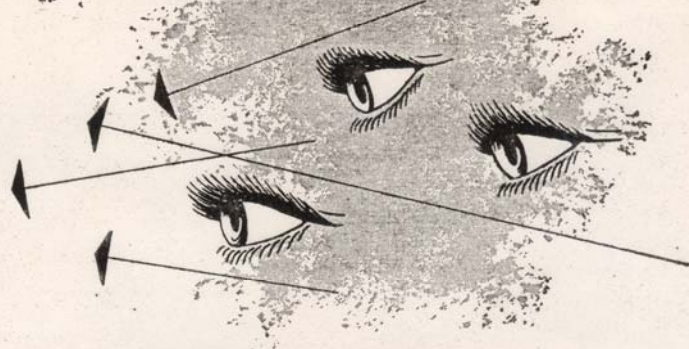

**famous hand-wrought Heisey  
MOONGLO stemware now retails  
at only \$24 per dozen**

Watch your customers' eyes gleam with delight when you tell them they can own beautiful Heisey *Moonglo* stemware at this surprisingly low price. *Moonglo's* lovely cutting on Lariat hand-blown crystal provides great versatility—harmonizes with table settings that are formal or sophisticated, romantic or carefree.

Like the other two brilliant crystal creations shown here—*Heisey Rose* and *Plantation Ivy*—*Moonglo* is available in a complete assortment of stemware and matching table accessories.

*The finest in glassware . . . made in America by hand and nationally advertised for more than fifty years*

*Moonglo, Heisey Rose, and Plantation Ivy will all be advertised this fall in such leading women's magazines as Better Homes & Gardens, House Beautiful, Living for Young Homemakers, Bride's Magazine and Sunset. Capitalize on this by tying in your displays and newspaper ads. Your Heisey Representative will see that your orders get prompt attention and that you are well supplied with effective tie-in material.*



Plantation Ivy



Heisey Rose



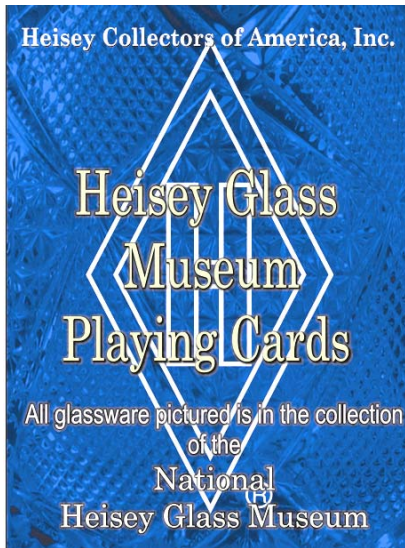

# HEISEY GLASS MUSEUM PLAYING CARDS

Edition 3 (green deck) of Heisey Glass Museum Playing Cards are now in. In addition, we have for sale a limited number of uncut sheets (21" x 25") which will be suitable for framing. This deck features the Heisey animals and animal related items. The full color pictures are stunning and will make a good learning tool as well as a nice gift for all of your glass collecting friends. We will ship as soon as available. Orders for Card Cases (Cobalt) and the Red deck may also be placed on this form.

Name \_\_\_\_\_  
 Address \_\_\_\_\_  
 City \_\_\_\_\_ State \_\_\_\_\_ Zip \_\_\_\_\_  
 Phone and/or E-mail \_\_\_\_\_

I wish to order:	Total
_____ (number) Heisey Glass Museum Playing Cards (Green) @ \$10 each	_____
_____ (number) Heisey Glass Museum Playing Cards (Red) @ \$10 each	_____
Shipping per deck \$ 1.50 (can be picked up at Gift Shop)	_____
_____ (number) Uncut sheets of Heisey Playing Cards (Green) @ \$25 each	_____
_____ (number) Uncut sheets of Heisey Playing Cards (Red) @ \$25 each	_____
Shipping per uncut sheet @ \$5.00 each (can be picked up at Gift Shop)	_____
_____ (number) 1508 Card case in Cobalt @ \$24.95 each	_____
Shipping per card case @ \$6.00 each (can be picked up at Gift Shop)	_____
<b>Grand Total</b> (tax will be added when appropriate)	_____

Check # \_\_\_\_\_ Visa \_\_\_\_\_ Master Card \_\_\_\_\_  
 Card Number \_\_\_\_\_ Exp \_\_\_\_\_

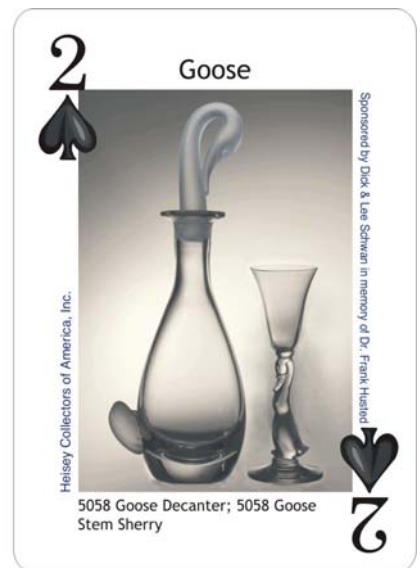
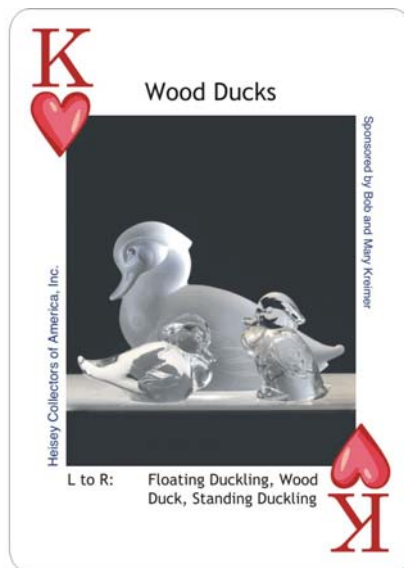
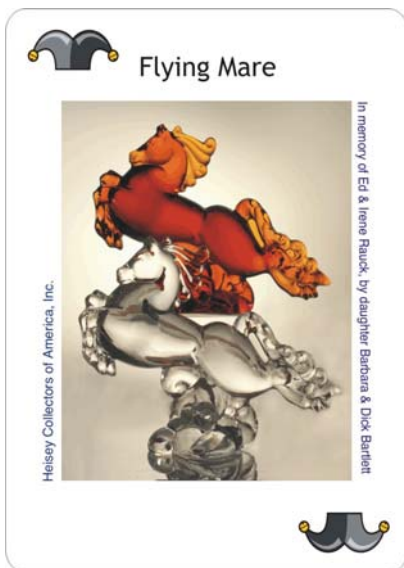

# Study Club Directory

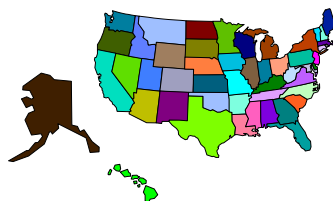

**Interested in joining a study club?** You will have the opportunity to meet fellow collectors and HCA members and learn more about your favorite glassware. If your club is not listed or you need to make corrections to your listing, please contact the Museum.

STUDY CLUB	MEET WHEN?	WHERE?	Email/Web Site	CONTACT
#4 Central Illinois Heisey Collectors Club	Four times a year	Members' homes or restaurants		Joyce Deany (815) 432-4310
#5 Bay State Heisey Collectors Club	2 <sup>nd</sup> Tuesday of each month except July, Aug., and Dec.	Whole Foods Community Rm, Bedford, MA	spescatore@houghton.com	Stephen Pescatore (978) 256-5418
#7 Dayton Area Heisey Collectors Club	3 <sup>rd</sup> Tues. of the month Sept. to May, 6:30 p.m.	Huber Heights Library	LH937@aol.com	Joe Harner (937) 372-0852
#8 Heisey Heritage Society <i>NJ, Eastern PA and DE areas</i>	Four times per year	Members' homes	craigkratochvil@aol.com	Craig Kratochvil (973) 962-4004
#13 Heisey Club of California	4th Sunday every month, 12:30	Members' homes	herbet@sbcglobal.net www.heiseyclubca.org	Norval Heisey (818)-349-0945
#14 Northern Illinois Heisey Club	Four times a year	Members' homes	niheisey@comcast.net	Jeff Morrow (630) 833-4644
#15 Heisey Collectors Club of Michigan	Every six weeks, August to May	Members' homes	kilgoredesigns@att.net	Sue E. Kilgore (269)-345-3990
#16 Heisey Collectors of Texas	2 <sup>nd</sup> Sat. of every odd month except May 1 <sup>st</sup> Sat., 1 p.m.	Members' homes	sanddollars97@tx.rr.com www.heiseycollectorsoftexas.org	Greg Freeman (817)-545-5889
#19 Heisey Collectors of the Rochester Area	10 meetings per year: Sunday, 2:30 p.m.	Members' homes	seo2@aol.com	Sharon Orienter (585) 288-8076
#20 Buckeye Heisey Collectors Club <i>Newark, OH area</i>	September to May, 4th Monday	Members' homes or the Museum	Theflyingmaher@webtv.net	Michael Maher (740) 763-4256
#22 Northwest Heisey Collectors	First Saturday of the month	Members' homes	bahama50@hotmail.com	Deborah de Jong (425) 868-0457
#25 Heisey 76'ers <i>Columbus, OH area</i>	Once a month, September to May	Members' homes	ldburg48@aol.com	Colleen Burgess (614) 882-1884
#31 Nassau Long Island Heisey Club	Generally every other month	Members' homes		Babs Kent (516) 228-8274
#32 Dairyland Heisey Club	Once every two months	Members' homes		Ray K. Courtmage (414) 962-9747
#33 Golden Gate Heisey Collectors Club <i>Northern California</i>	Quarterly	Members' homes		Russ Nicholas (916) 515-8558
#36 Heisey Club of Southern MA	April, June, September, December			Maria Martell (508) 833-0633
#38 North Carolina Heisey Study Group	6 meetings per year: Jan.; March, May, July, Sept., Nov.	Replacements Ltd Greensboro, NC	Nchsg@yahoo.com www.northcarolinaheiseystudygroup.org	Karen Taylo (252) 637-9985
#39 Florida Heisey Collectors Club	4 times per year: January – February-March-April	Westchester Country Club Boyton Beach, FL	Shirley400@aol.com	Everett Dunbar (772)-337-1558
#42 Gulf Coast Heisey Club of Florida	Nov., Jan. and March; 2 <sup>nd</sup> Thursday 11:00 am	Members' homes		Jack Grenzebach (727)-391-5784
#43 Tri-State Heisey Study Club <i>OH, IN, MI</i>	1 <sup>st</sup> Sat. every 3 <sup>rd</sup> month	Members' homes	Maxwellm@cktech.biz	Mike Maxwell (260) 925-3484
#45 Hoosier Heisey Club	Four times a year	Warren Library, Indianapolis, IN		J. David Litsey, (317) 872-7800
#48 Dixieland Heisey Study Club	Odd number months, 2 <sup>nd</sup> Saturday night	Members' homes	www.dixielandheisey.org	Craig German (770) 967-8733
#49 Great Plains Heisey Club	March, May, July, September, and November	Members' homes	cameron_mg@mchsi.com www.greatplainsheiseyclub.org	Mary Cameron (515) 292-3743
#50 Northwoods Heisey Club of Minnesota	Four times a year	Members' homes	wheise@comcast.net	Bob Heise (952)-831-9335
#51 Heisey Club of Northeast Florida	Feb., May, Aug., and Nov. 2 <sup>nd</sup> Thursday	Avonlea Antique Mall, Jacksonville	Clasyglas2@aol.com	Barb Bartlett (904) 280-0450
#52 Northern Virginia Heisey Study Club	Monthly, Sept. – May	Members' homes	rreopell@verizon.net	Russ Reopell (703) 250-6117

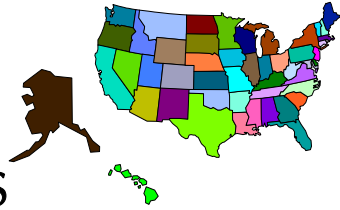

## CLUB NOTES

**Great Plains Heisey Club**  
*Kathy Files*

On July 18, 2009, 25 members of the GPHC met in Omaha, NE, and got the best of the “Nebraska Good Life” at the golf course home of John and Trudy Mock. The weather was spot on perfect and we all devoured delicious taco salad that heapingly filled two large Heisey punch bowls – a clever alternative use of our favorite glassware. After a choice of three desserts (some tried all three), we began our meeting with the call to order by President John Mock.

Previous minutes were approved and the treasurer’s report was given. We were pleased to have donated \$1,100 to HCA at the Convention (\$550 to the operating fund and \$550 to the endowment fund) plus over \$50 of meats, cheese, buns, and crackers to the Hospitality Room.

We were all so thankful to have Jean Will in attendance and looking fit and fine. Jean took the time to thank everyone in our club for their cards, concern, and prayers after her heart attack and extended that thanks to other HCA friends.

Those of us who attended the 2009 Convention shared detailed news of that well-run event – it was noted more of our members expected to attend in 2010.

Trudy’s “Martha Moment” was to share ways of using Heisey pieces for the display and storage of cosmetics or other items in the bathroom. For the program, we had the fun of playing the “ABC’s of Heisey” with 26 pieces of Heisey placed on a table for everyone to identify. Trudy had devised this game of one pattern name for each letter of the alphabet (with one

letter at the end of the pattern name—always a ‘Twist’ in our programs)! Thank you, Trudy, it was informative and lots of fun. We recommend other study clubs do this program to learn Heisey patterns while having a good time. Congratulations to Eric who won the Fandango cream and sugar for having all the correct answers.

Show and Tell followed and our members have obviously been busy buyers this summer. Way too much to list. Check out Gregg’s pictures on our website [www.greatplainsheiseyclub.org](http://www.greatplainsheiseyclub.org). Following is just a sampling: 3397 Gascony footed soda in Tangerine; 7102 & 7148 Wide Zipper and Zipper humidor/cigar jars; 493 cologne with 679 Windsor cutting; Plaid 24” vase; 150 Pointed Oval in Diamond Point ½ gallon jug in Emerald; Duck insert in # 15 floral block in Flamingo; 3416 Barbara Fritchie cordials with Cobalt and Sahara bowls; 1187 Yeoman 3 compartment spice tray with 3 inserts; medium Elephant; Giraffe looking back; 4052 National goblet with 9023 Fred Harvey etch; 1306 Comet Leaf goblet; 335 Prince of Wales cruet and table cream and covered sugar; 141 Edna candlesticks; 1404 Old Sandwich round cream and sugar; 419 Sussex goblets – one with Moongleam stem and foot, one with Moongleam bowl; 1503 Crystolite cigarette box in Sultana; 903 Jefferson goblet; 461 Convex Circle 2 qt. crushed fruit; 353 Medium Flat Panel toothbrush holder in Hawthorne; 5058 Goose decanter with frosted stopper and tail; 6060 Country Club 3 pint cocktail shaker with 517 Winchester ‘73 etch; 21 Aristocrat 3.5” desk candlesticks; unknown Heisey pressed pattern 15 inch sandwich plate named Quilted Double Square by the owner; 1447 Rococo whimsey in Cobalt made from a plate.

Our last activity was an auction of many fine pieces of glass, books, etc. All successful bidders were pleased with their new items—we have a great group of generous members! Thanks to everyone who donated to help replenish our treasury and thanks to the buyers.

Our meeting was adjourned but flowers and plants were dug up and shared with members to go to other states.

Thanks to the Mocks for hosting and feeding us so much yummy food. They always draw a crowd; even had Ryan Lucke attend with his grandparents Pat and Rex. Our next meeting will be in Clay Center, NE on September 26 hosted by Marilyn Sampson and Lynn and Sherrill Echternkamp. This will be our first meeting in two homes – a ‘progressive’ club session. The program will be on Heisey goblets. More details to follow – bet we’ll have more fun. ♦

### Advertising Guidelines:

Advertising: Ads may be mailed to: HCA Advertising, 169 W. Church St., Newark, OH 43055; faxed to (740) 345-9638; or e-mailed to [curator@HeiseyMuseum.org](mailto:curator@HeiseyMuseum.org). Whenever possible, please e-mail your ad. Include your MasterCard or VISA number and expiration date for billing purposes, or send a check. All ads must be prepaid. When mailed or faxed, ads should be typed or printed on white paper with dark ink. Please double space. Ads that are entered in a vertical column format may contain a maximum of 65 characters per line, including spaces & punctuation.

Classified: 20 cents per word (members), 30 cents per word (non-members), \$1.50 min., 1/8 page limit. Personal ads 1/8 page limit. Abbreviations & initials count as words.

Display Ads:	member	nonmember
1/8 page (12 lines)	\$ 20	\$ 30
¼ page (25 lines)	\$ 40	\$ 60

½ page (60 lines, horizontal or vertical)	\$ 80	\$120
Full page (120 lines)	\$160	\$240

A charge of \$1.60 will be added for each additional line.

½ page: 4½" high by 7½" wide or 9" high by 3½" wide

Full page: 9" high by 7½" wide

Ad copy must be received by the first of the month prior to publication. Reproductions (i.e., Heisey by Imperial) must be indicated. Heisey News accepts no further liability. In the event of a typographical error, the incorrect portion of the ad will be run in the following issue, but HEISEY NEWS assumes no further liability.

**Abbreviations:** DF = Dolphin Foot NO = Narrow Optic  
DO = Diamond Optic SO = Spiral & Saturn Optic  
MO = Medium Optic WO = Wide Optic

### Classified Ads

## Find the Best of Heisey Glass...

...with popular patterns like Orchid, Heisey Rose, Minuet, and hundreds more. We also carry other fine crystal and depression glass from Cambridge, Fostoria, Imperial, Duncan & Miller, and more. The world's largest supplier of old and new china, crystal, flatware and collectibles, Replacements, Ltd. carries over 11 million pieces in inventory in over 250,000 patterns.

If you're looking to add to your collection, or if you're looking to sell — call us toll-free. We're always looking for more.



**1-800-REPLACE (1-800-737-5223)**

♦ *Paid Ad*

## PUBLIC AUCTION Of Heisey Animals

Saturday August 15, 2009 at 10 AM.

Location: 1626 Burson Dr. Findlay, OH 45840. Burson Dr. is south of Sixth St. Sixth St. runs between SR 37 (Blanchard Ave.) and S. Main St.

Approx. 35 pieces to be sold. Several of the rare ones will be offered with reserve. Call for a list or visit our web page (listed below under our name) for the list and pictures.

**Terms:** Cash or check with acceptable ID on sale day. Visa & MC + 3%. Out of state buyers will be cash or acceptable credit card. Not responsible for accidents or for items after sold. Lunch on grounds.

**Owner:** Mildred Dove

**Walter Bros. Inc. Auctioneers**

Ben, Tom & Matt Walter, Kris Gosche

901 N. Main St., Findlay, OH 45840

419-424-0944 [www.walterbrosinc.com](http://www.walterbrosinc.com)

♦ *Paid Ad*

## REAL HEISEY IN THE GIFT SHOP

All crystal and all prices are each unless noted.

Supply changes daily. Please contact the Gift Shop before placing an order.

Item	Price
134 Trident 2 lt candlestiks, silver overlay, pr	\$40
337 Touraine wine, H (2 each)	10
343 Sunburst butter top only H	25
350 Pinwheel & Fan punch cups, H (2 each)	10
351 Priscilla butter pat, H	10
394 Narrow Flute 4 1/2" chow chow, H	25
394 Narrow Flute salted nut, H	10
411 Tudor cruet, H	35
411 Tudor punch cup, H (2 each)	5
413 Tudor champagne, H (4 each)	10
413 Tudor sherbet, H	5
475 Narrow Flute/Rim salted nut, plain bottom H	15
500 Octagon tray, 6", Moongleam	10
1183 Revere individual salt (4 each)	12
1184 Yeoman cocktail, H	10
1184 Yeoman goblet, H, Flamingo	30
1225 Plain Band child's butter bottom only	15
1252 Twist mint, H, Marigold	20
1252 Twist cheese plate, H, Marigold	20
1295 Beaded Swag nappy, 4", Emerald	20
1401 Empress plate, 8" sq, 448 Old Colony, Sahara, H (4 each)	15
1404 Ipswich sherbet (2 each)	10
1425 Victorian punch cup, H (7 each)	5
1483 Stanhope cream/sugar, no knobs, H	30
1483 Stanhope cup, no knob (6 each)	15
1503 1/4 Crystalite sq candleblocks, pr	25
1519 Waverly pickle/olive	10
1519 Waverly plate, 8" (2 each)	5
3362 Charter Oak finger bowl, blue/gold stain	10
3384 Creole ftd bar, 2 oz., Sahara	60
3384 Creole soda, ftd, 12 oz., Sahara	40
3440 Portsmouth goblet, Moongleam ft (3 each)	20
4044 New Era oyster cocktail	5
4085 Kohinoor sherbets (2 each)	5
4085 Kohinoor soda, 10 oz	8

### NEW IN THE GIFT SHOP

Reprint of Catalog and Price List No. 31, September, 1950	\$12.95
Heisey Placemats (produced by Bay State Heisey Club)	\$14 each or 2 for \$25
Heisey Notecards, 12 cards each with a different Heisey etching plus envelopes	\$12

*"Ma'm, yo'll sho'ly fall in  
love with fascinatin'"*

*Lariat*



How gaily it gleams on your table . . . a bright idea in graceful individuality! You can create endless variety in your table arrangements with this distinctive pattern in Heisey Crystal. It's open stock, brightened by a gay array of pieces from which to make your choice.

Start *your* Lariat collection now with goblets, salad plates . . . and other pieces whenever you wish. Write for Lariat folder. A. H. Heisey & Co., Newark, Ohio.

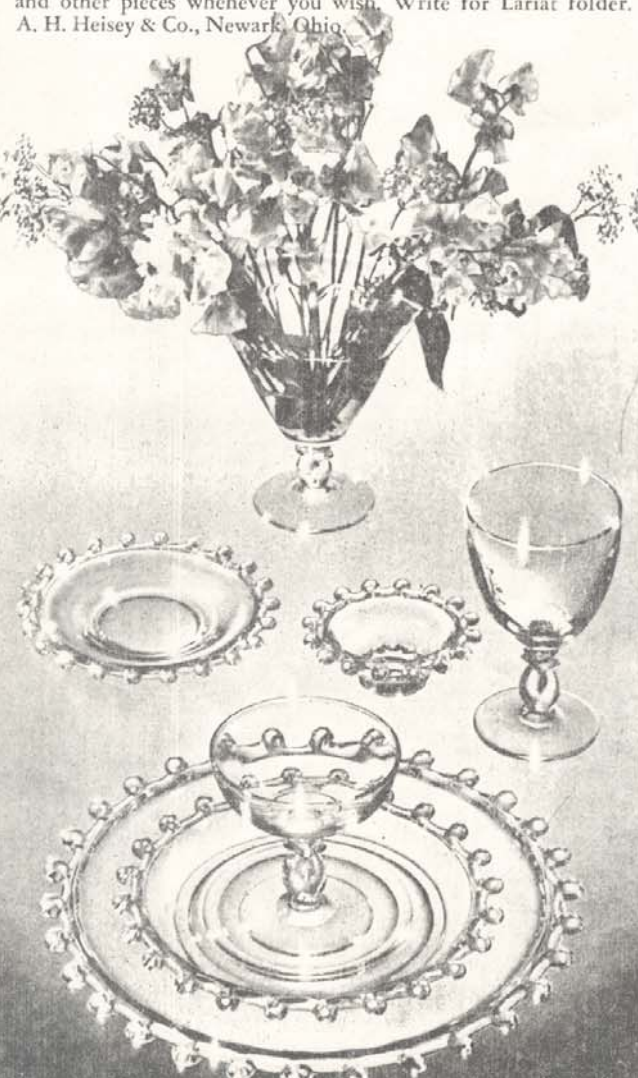

*"Remember to see Lariat  
(AND BUY LOTS MORE WAR BONDS)"*

**HEISEY'S**

HAND-WROUGHT  CRYSTAL

Lariat Advertisement, House Beautiful,  
March 1944

# Dealer Directory

Maximum 6 lines/12 months/\$35 MEMBERS ONLY

Contact the Editor to place your ad!



<p><b>KIM &amp; PAM CARLISLE</b> SHOWS &amp; MAILORDERS ONLY 28220 Lamong Rd. Dept. H Sheridan, IN 46069 Glass Cleaning Services Available (317) 758- 5767 <a href="mailto:kcarlisl@worldnet.att.net">kcarlisl@worldnet.att.net</a></p>	<p><b>SHIRLEY EUGENIA DUNBAR</b> Heisey a Specialty—Mail Order, Shows, Appraisals EMAIL: <a href="mailto:shirley400@aol.com">shirley400@aol.com</a> PO Box 8344, Port St. Lucie, FL 34952 Oct-May (772) 337-1558 PO Box 222, Naples, ME 04055 May-Oct (207) 647-5652</p>	<p><b>SUM OF LIFE</b> Elaine Husted: 610-469-1243 Traveling through eastern PA Call, stop in, be a buyer or a browser!! E-mail: <a href="mailto:1classycat@comcast.net">1classycat@comcast.net</a></p>
<p><b>ALL HEISEY AUCTION</b> Consignments Welcome Apple Tree Auction Center 1616 W. Church, Newark, OH 43055 (740) 344-4282</p>	<p><b>MOUNDBUILDERS SECOND GENERATION</b> Barbara and Richard Bartlett Heisey Exclusively! 1-904-280-0450 PO Box 1931, Ponte Vedra Beach, FL 32082 Toll Free 1-888-434-7397(HEISEYS) EMAIL: <a href="mailto:CLASYGLAS2@AOL.COM">CLASYGLAS2@AOL.COM</a></p>	<p><b>EAGLES REST ANTIQUES</b> <i>Buying Heisey, China &amp; Pottery</i> Carl and Mary Evans 62 Fieldpoint Rd., Heath, OH 43056 (740) 522-2035</p>
<p><b>PAULA &amp; JEFF MORROW</b> Elegant Glassware and American Dinnerware 126 Clinton Avenue Elmhurst, IL 60126 <b>(630) 833-4644</b> <a href="mailto:mor-fab@comcast.net">mor-fab@comcast.net</a></p>	<p><b>H &amp; R DIAMOND H</b> Helen &amp; Bob Rarey 1450 White Ash Dr. Columbus, OH 43204 (614) 279-0390 after 5:30</p>	<p><b>CRYSTAL LADY</b> Bill, Joann &amp; Marcie Hagerty Specializing in elegant depression glassware 1817 Vinton St., Omaha, NE 68108 Shop (402) 341-0643 or Home (402) 391-6730 Email: <a href="mailto:ejhagerty@aol.com">ejhagerty@aol.com</a> website:<a href="http://www.crystalladyantiques.co">www.crystalladyantiques.co</a></p>
<p><b>REALMS IN GLASS</b> Roy Eggert Heisey Custom Stained Glass 9423 Saddlebrook Ct, Frederick, MD 21701 301-260-0234 <a href="mailto:roy54@hughes.net">roy54@hughes.net</a></p>	<p><b>PIECE BY PIECE ANTIQUES</b> Buy &amp; Sell Specializing in Heisey Glassware Bryan K. Baker Fairfax Station, VA 22039 Newark, OH 43055 (703) 250-6117 <a href="mailto:piecebypiece@verizon.net">piecebypiece@verizon.net</a></p>	<p><b>PATTON HOUSE ANTIQUES</b> Specializing in Glass*Heisey*Cambridge*Fostoria*Duncan* Factory Antique Mall, Verona, VA off I-81 Exit 227 Antiquers Mall, Booth 81, Rt. 29 N., Charlottesville, VA The Daniels, Box 547, Louisa, VA 23093 (540) 967-1181</p>
<p><b>C&amp;J ANTIQUES</b> Cole &amp; Jean Miesner Box 45, 72 Whig St. Newark Valley, NY 13811 (607) 642-9905</p>	<p><b>SIBYLS OF WILMINGTON</b> Sibyl &amp; Ned Lavengood at Castle Corner Antiques 555 Castle St. Wilmington, NC (910) 264-9597 or <a href="mailto:Sibylsantiques@bellsouth.net">Sibylsantiques@bellsouth.net</a></p>	<p><b>FRAN'S FANCY FINDS</b> Fran &amp; Jack Grenzebach 10534 Valencia Rd., Seminole, FL 33772-7511 (727) 391-5184 SHOWS MAIL ORDERS</p>
<p><b>The American Bell Association</b> P.O. Box 19443 Indianapolis, IN 46219-0443 <a href="http://www.americanbell.org">www.americanbell.org</a> m</p>	<p><b>PASTICHE ANTIQUES</b> at Preston's Antique Gaslight Village US 12, Allen, MI 49227 Elegant Glass and Other Fine Antiques <a href="mailto:pasticheantiques@gmail.com">pasticheantiques@gmail.com</a></p>	<p><b>WILLEY'S ANTIQUES &amp; MUSEUM</b> Specializing in Heisey 11110 Cannon Rd., Frazeytsburg, OH 43822 16 miles east of Newark, OH (740) 828-2557</p>
<p><b>CHARLES &amp; MILDRED FISHER</b> Heisey animals and Heisey By Imperial animals 1607 Dayton Rd, Newark, OH 43055 <a href="mailto:Cfisher08@roadrunner.com">Cfisher08@roadrunner.com</a> (740) 281-3104</p>	<p><b>MARSH'S ANTIQUES</b> Dick and Virginia Marsh 4532 Newton Road Newark, OH 43055 <a href="mailto:swamp@alink.com">swamp@alink.com</a> (740) 366-5608</p>	<p><b>MOONGLEAM ANTIQUES</b> Heisey Glassware &amp; American Art Pottery John Woytowicz and Peter Rivard 70 Pleasant St., Gardiner, ME 04345 (207) 582-9048 E-mail: <a href="mailto:jmwpwr@aol.com">jmwpwr@aol.com</a></p>
<p><b>ROBERT M. LOCH</b> Voting Member HCA and NWHC Pacific Interstate Glassware Co. PO BOX 469 Custer, WA 98240 360-366-3166</p>	<p><b>CRESTONE MANOR UNIQUES</b> Harold &amp; Loleta Hammontree 3317 Crestone Circle, Chattanooga, TN 37411 423-629-1274 <a href="mailto:hammonl@bellsouth.net">hammonl@bellsouth.net</a> Heisey Only</p>	<p><b>APPLE VALLEY COLLECTIBLES</b> Richard &amp; Marilyn Garnett – Owners Shows/ Mail Order (845) 691-8799 Email: <a href="mailto:diamondH95@aol.com">diamondH95@aol.com</a></p>
<p><b>DOWNSTAIRS AT FELTON ANTIQUES</b> 100B Felton St, Waltham, MA 02453 781-894-2223 <a href="mailto:info@feltonstreetantiques.com">info@feltonstreetantiques.com</a> GLASSWARE, POTTERY, EPHEMERA, STERLING, FURNITURE FROM EVERY DECADE!</p>	<p><b>WM GLASS</b> Bill &amp; Mary Barker 400 Nantucket Ave., Pickerington, OH 43147 (740) 927-0918 <a href="mailto:mcbarker@embarqmail.com">mcbarker@embarqmail.com</a> Heisey Only</p>	<p><b>WATERSEDGE ANTIQUES</b> Norene &amp; Don Walzer Shows &amp; Mail Order 25089 Riverwalk Drive Leesburg, FL 34748 (352) 314-8975 <a href="mailto:dnnwalzer@embarqmail.com">dnnwalzer@embarqmail.com</a></p>
<p><b>JERRYS' ANTIQUES</b> Shows Only Glassware and Other Fine Collectables PO Box 4485, Davenport, IA 52808 563-340-1871 <a href="mailto:jerrysantiques@mchsi.com">jerrysantiques@mchsi.com</a></p>	<p><b>ONCE AND FUTURE ANTIQUES</b> Susan &amp; Stephen Pescatore 9 Donna Rd. Chelmsford, MA 01824 (978) 256-5418 Heisey and Elegant Glass</p>	<p><b>BOB &amp; MARY KREIMER</b> Specializing in Heisey Glass 7044 SW 116<sup>th</sup> Loop, Ocala, FL 34476 (352) 873-8306 email: <a href="mailto:rkreimer@earthlink.net">rkreimer@earthlink.net</a>. Shows and Mail Orders Only</p>
<p><b>J &amp; L TREASURES</b> Specializing in Heisey, Cambridge, Fostoria, Tiffin, Morgantown, etc Linda Kilburn, PO Box 1257, Burlington, CT 860-673-4088 <a href="mailto:jltreasures@comcast.net">jltreasures@comcast.net</a></p>	<p><b>Charlene Bowman</b> Shows Only Heisey – Cambridge – Fostoria - Morgantown P.O Box 287, Clarksville, OH 45113 937-289-2114 <a href="mailto:twoclbs@aol.com">twoclbs@aol.com</a></p>	<p><b>YELLOW BRICK ROAD ANTIQUES</b> Jean Will Leavenworth, KS 66048 (913) 682-4831 Specializing in Heisey and Elegant Glassware Shows and Estate Sales</p>
<p><b>Just in Time Antique Mini Mall</b> 29 North Third St Newark, OH 43055 Heisey in Stock 740-349-0001 <a href="mailto:ntleblanc@aol.com">ntleblanc@aol.com</a></p>	<p><i>Your Ad Could be Here</i></p>	<p><i>Your Ad Could be Here</i></p>

## When Renewing Your Membership

Help ensure the future of your Museum. When you renew your membership at one of the levels below, any amount beyond the regular Associate dues goes into the Endowment Fund.

<i>Individual Contributing, one person in household</i>	<i>\$50</i>
<i>Joint Contributing, two people in one household</i>	<i>\$60</i>
<i>Family Contributing, parents and children under 18</i>	<i>\$75</i>
<i>Patron</i>	<i>\$125</i>
<i>Sponsor</i>	<i>\$250</i>
<i>Benefactor</i>	<i>\$500</i>

Visit The  
National  
Heisey  
Glass  
Museum



Come at your leisure to enjoy more than 4,800 pieces of glassware produced by A.H. Heisey and Company from 1896-1957. Hundreds of patterns are featured in all production colors. Rare and experimental items are included as well.

Facilities are air-conditioned and handicapped-accessible. Hours are 10:00 a.m. to 4:00 p.m. Tuesday through Saturday, 1:00 to 4:00 p.m. Sunday (except Jan. and Feb.). Members are admitted free, regular admission is \$4. Office hours are 8:00 a.m. to 4:30 p.m. weekdays.

**Membership Renewal Notice:** Check the date above your name and address on the mailing label. This is your expiration date. If it reads 8-10-09, make sure your dues are paid soon in order to receive next month's issue of *Heisey News*.

Contact the HCA Administrative Office at (740) 345-2932 for more information. The Endowment Committee wishes to thank those who have become Endowment Members and all of the individuals and study clubs that have so generously supported the HCA Endowment Fund. All members who have supported the fund are recognized each year in the February issue of the Newsletter. Your support will make the Museum self-sustaining in the years to come. Thank You all! ♦

### Shipping & Handling Fees for Outside US

Additional shipping charges are required for members living outside the U.S. Current rates are Canada, \$22; for other countries, contact the Museum. Rates are subject to change at any time due to rate changes made by the US Postal Service. To verify current rates, call (740) 345-2932 or E-mail [business@HeiseyMuseum.org](mailto:business@HeiseyMuseum.org)



### Periodical Postage

Paid at the Post Office  
In Newark, OH 43055  
Publication # 00986  
POSTMASTER SEND FORM 3579 TO:  
HCA  
169 W. Church St.  
Newark, OH 43055

To: \_\_\_\_\_

## Museum Volunteers for June 2009

Bryan Baker  
Jim and Karen Clark  
Tom and Kathy Files  
Chuck & Amy Jo Jones  
Dan and Sue Kilgore  
Frank Kuhlmann  
Robert Loch  
Dick Marsh  
Phyllis McClain  
Jack Metcalf  
Don & Pat Moore  
Sharon Orienter  
Ginny Priest  
Russ Reopell  
Judy Rhoads  
Dick & Marilyn Smith  
Dave & Mary Ann Spahr  
Karen Taylo  
Charlie & Susan Wade