

# HEISEY NEWS

The Official Publication of Heisey Collectors of America, Inc.

Volume XXXVIII No. 7

July 2009

ISSN 0731-8014

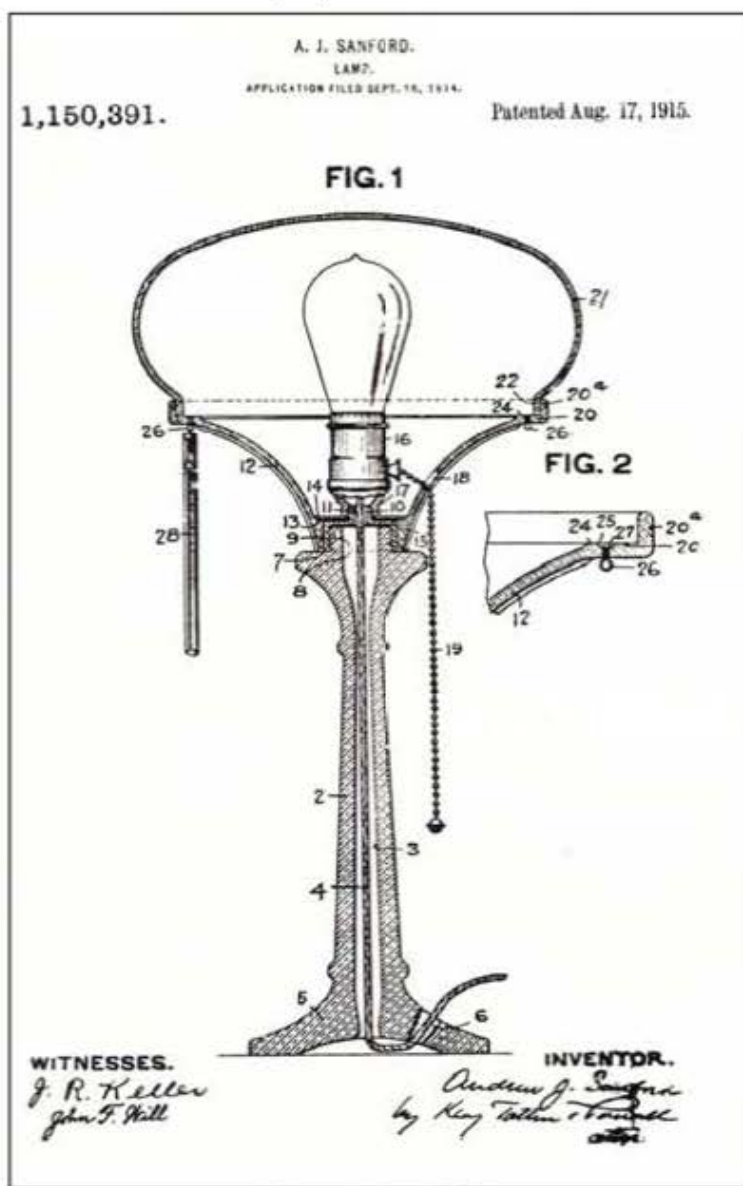

Patent 1,150,391

Read Part Five of the Story of A. H. Heisey Utility Patents on Page 5

## HEISEY NEWS

Heisey Collectors of America, Inc.  
169 West Church Street  
Newark, Ohio 43055  
Phone 740-345-2932 Fax 740-345-9638  
Web Site: www.heiseyMuseum.org  
All Rights Reserved 2009  
ISSN 0731-8014

### Staff and Phone Extensions

Curator, Walter Ludwig, curator@heiseyMuseum.org, Ext. 4  
Clerks, Justin Church, Amanda McDonald, Micki Wareham  
membership@heiseyMuseum.org, Ext. 1  
Gift Shop, Ext. 5

### HCA Board of Directors:

**President**, Sue Kilgore – Kalamazoo, MI, 269-345-3990 –  
hcapresident@heiseyMuseum.org  
**Vice-President**, Karen Taylo – New Bern, NC, 252-637-9985  
**Secretary**, Charlene Bowman – Clarksville, OH, 937-289-2114  
**Treasurer**, Sharon Orienter – Rochester, NY, 585-288-8076  
Member-at-Large, Dave Spahr - Xenia, OH, 937-372-7166

Bryan Baker - Fairfax Station, VA, 703-250-6117  
Sid Edwards – Tallassee, AL, 334-283-4663  
Tom Files – Kansas City, MO, 816-468-7087  
Amy Jo Jones - Beavercreek, OH, 937-426-1567  
Bob Kreimer – Ocala, FL, 352-873-8306  
Robert Loch – Custer, WA, 360-366-3166  
Jack Metcalf – Utica, OH, 740-892-2664

HEISEY NEWS is published and printed monthly, by Heisey Collectors of America, Inc. (HCA). Periodical postage paid at Newark. Subscription is limited to HCA members. First class mailing is available for an extra \$20.00, due with payment of membership. If you are having difficulty receiving your Newsletter, please contact the HCA Administrative Office Monday through Friday 8:30 a.m. - 4:30 p.m.

The opinions expressed in articles in HEISEY NEWS are those of the authors and not necessarily those of the organization. The Editorial Staff reserves the right to edit, with or without the consent of the author or to refuse any material submitted for publication.

### Back Issues

Back Issues available from files are \$3.00 per issue plus shipping and handling

### Advertising

Ads may be mailed to: HCA Advertising, 169 W. Church St., Newark, OH 43055; faxed to (740) 345-9638; or e-mailed to curator@HeiseyMuseum.org. Whenever possible, please e-mail your ad. Always include your MasterCard or Visa number and expiration date. When mailed or faxed, ads should be typed or printed on white paper with dark ink. Camera ready ads are accepted, but must follow line specifications outlined at the beginning of the advertising section. Ads containing reproductions will not knowingly be accepted unless clearly stated (e.g. Heisey by Imperial, etc.). HEISEY NEWS accepts no further liability. In the event of a typographical error, the incorrect portion of the ad will be run in the following issue, but HEISEY NEWS assumes no further liability. See advertising section for rates and deadlines.

### Museum

Heisey Collectors of America, Inc., a non-profit corporation (tax-exempt status), owns and operates The National Heisey Glass Museum in Veterans Park, 6th and Church Streets, Newark, Ohio. Open year round, Tuesday through Saturday 10:00 a.m. – 4:00 p.m., Sunday 1:00 – 4:00 p.m. (except Jan. and Feb.), closed holidays. Other hours by appointment. Members admitted free.

### Identification

HCA will attempt to identify unknown glass items. Send a color photograph, measurements, and a self-addressed, stamped envelope to the attention of the Curator. Other arrangements should be made in advance with the Museum staff. Please keep in mind that the Museum cannot appraise items. Identification is free to members, non-members \$5.00 per item.

### Membership

To join Heisey Collectors of America or to renew your membership, contact the HCA Administrative Office Monday through Friday 8:00 a.m. - 4:30 p.m. Eastern Time. Associate dues are \$30.00 plus \$5.00 for each additional household member. Voting members pay an additional one-time fee of \$25.00. Please consider supporting the Endowment Fund by joining at one of the levels listed on the back page.

### Museum Gift Shop

There is always someone in the Gift Shop during the Museum's hours of operation to help answer questions or take orders. When ordering by phone, please have a credit card ready. When ordering by mail, please be sure to include appropriate charges such as shipping and sales tax. Please note that the HCA member discount does not apply to original Heisey or special project items.

### Shipping and Receiving

Delivery is made much easier when we have a complete street address, not a PO Box. We prefer to use UPS. If you have not received a package, please call the Administrative Office to confirm it was sent. We will assist you in tracing it. If your package arrives damaged, please contact your local UPS representative. We insure everything.

### Donations and Loans to the Museum

If you would like to make a donation to the Museum or have questions regarding items on loan, contact the Curator. HCA reserves the right to accept or refuse items based on current holdings.

## HEISEY CALENDAR OF EVENTS

### 2009

Percy and Vivian Moore Memorial Weekend	October 2-3
2009 Fifth Heisey Select Auction	October 3
December Holiday Open House	December 5

### Table of Contents

Utility Patents Associated with A.H. Heisey & Company (Part 5), Walter Ludwig	FC & 5-7
Heisey Calendar of Events	2
Message from the President, Bryan Baker	3-4
Curator's Report, Walter Ludwig	4
HCA Welcomes New Members for May 2009	4
464 Punt Row, Joe Lokay	8
1254 Sherbet, Walter Ludwig	8
Reprints of Original Advertisements, Cuttings	9-10
Special Exhibit – Krall Family Glass, Walter Ludwig	11-12
The Krall Glass Engravers: Their Life and Contributions to the Glass Industry, Anton Krall	12-15
Annual Financial Report to Membership, Sharon Orienter	15-16
Financial Report to Membership, Sharon Orienter	16
HCA Convention 2009 Recap, Mary Ann Spahr and Judy Rhoads	16-18
Heisey Hospitality Recap, Karen Clark and Pat Moore	18-19
New Reproduction Hits the Market, Walter Ludwig	19
Pictures from 2009 Convention Barbeque	20
Pictures from 2009 Convention Banquet	21-22
Heisey Glass Museum Playing Cards, Order Form (Green Deck)	23
Study Club Directory	24
Club Notes	25
Advertising Guidelines	25
Classified Ads	26
Dealer Directory	27
Museum Volunteers for May 2009	BC

## MESSAGE FROM THE PRESIDENT

Bryan Baker

Our Annual Convention is now a distant memory. We had a great time in Newark this year; however, it was not without the hard work of our co-chairs Judy Rhoads and Mary Ann Spahr. Not to mention the countless volunteers that assisted along the way, in addition to our ever dedicated staff. Our Study Clubs and members alike stepped up as they always do with their generous donations and support of all the festivities. If you didn't make it this year; you can catch a glimpse of the festivities on pages 20-22. Thank you all for another successful Convention!

I'd like to take this time to welcome our newest board members; Charlene Bowman of Ohio, and Bob Kreimer of Florida. Karen Taylo of North Carolina has been re-elected to a second term. Great to have you all on board!



**President Baker Swearing in Elected Board Members**

I wish to thank Charlie Wade and Ron Keener for their dedicated service to HCA as board members. They will be missed – thanks guys for your support over the years!

Being a board member is a rewarding experience, yet not without its challenges. I believe I can speak for all board members when I say that we strive to put HCA's best interests first and foremost in our actions. I am proud to be in such good company.

My last five years on the board has been spent serving the first two years as Vice President, and the past three years as your President. The HCA Constitution states that the President can only serve three consecutive years in that office. I, therefore, am not eligible for another term. It is at this time I proudly announce our Executive Committee for the upcoming year: President Sue Kilgore, Vice President Karen Taylo, Treasurer Sharon Orienter, Secretary Charlene Bowman, and Member at Large Dave Spahr. Please throw your support behind these individuals and the entire board as they provide dedicated leadership for HCA.

As you know, serving on the Executive Committee has required me to make monthly (sometimes more) trips to Ohio from Virginia - at last count, I have made over 70 round trips. Believe me, I have no regrets; but I will be looking forward to spending more at home time, so to speak.

Looking back, I look at the accomplishments we have made over the last few years. Working with state and local governments we have improved our recognition in the community – we are now the official glassware in the Ohio Governor's Residence! Our Museum collection has received a much needed face lift, we have new computers and financial accounting software, our new website is nearing completion, and we have begun what, I believe, will be a most exciting new edition to our exhibits: an area dedicated to the Heisey Factory and the highly skilled artisans that worked there. This is just a few of our endeavors that have given positive change to our institution. I'm sure many more will come in the future.

I want to take this opportunity to thank all of those who have given their unyielding support – you have made this experience worth every second. From our first President Louis Ream to our newest President; your continued support to them and HCA is vital – and never taken for granted.

Before signing off one final time, I regret having to inform you of the passing of James Van Winkle, Jr. Jamie and his family are long time members and supporters of HCA and our Museum. Our deepest condolences go out to Jamie's family and friends.

With much gratitude,

Bryan Baker ♦

## CURATOR'S REPORT

Walter Ludwig

Convention has come and gone now, and it was another great one. The weather could not have been nicer. Oh, there was a threat of rain here and there, but it all cleared up in plenty of time for the events not to be bothered. For the most part it was not too hot and not too cool either. One could say almost perfect.

People started arriving early in the week and if they looked like they had nothing to do, we put them to work. I am sure I surprised Tom Files when I gave him a broom and asked him to clear away some of the dirt that had accumulated on the front of the Museum. Everyone chipped in with good cheer, and we soon had all of the last minute chores accomplished. On Tuesday, the Museum was packed as everyone caught up with all their Heisey friends that they had not seen in a while. Even if it was your first Convention, you soon felt like an old timer as you swapped the story of your latest find with someone who could hardly wait to top you. There is nothing quite like being able to share your favorite pastime with someone who understands your passion.

By Wednesday, everyone was high with the anticipation of the start of the official events. We had our kick-off barbeque at a new facility this year located just north of the OSU-Newark Campus. It was a beautiful covered pavilion that fit our enthusiastic crowd to a tee. The fact that the food was excellent and plentiful did not hurt either.

Finally, on Thursday the big day was finally here. The show opened at noon for a special one hour preview for those that were registered for the Convention. And, as in past years, the beauty and variety of glass that our dealers brought us was outstanding. Bags were making the steady treks back to the car, just to be replaced by further treasures. I am sure everyone there bought a piece of Heisey or two.

I did two seminars this year on the floor of the Convention show. They worked out well and were well attended. Some people even said I did ok. I do want to give a special thank you to those that loaned some samples of rarer etchings that the Museum did not have – Dick and Marilyn Smith, Susan Pescatore, Eric Tankesley-Clarke, and Marian Dalton. These in addition to samples from the Museum's collection made quite a display.

Of course, there were other great events during Convention including the ID and Show and Tell Session, the annual meeting, and the Banquet and Special Auction. On Saturday, we got up and all went down to the square to see the treasures that awaited us there. It was another Heisey buying frenzy with many more pieces finding new owners. After being on the square, I came back to the Museum and met members of the Krall family who were having a reunion here in Newark because of the special display of Willibald Krall cut pieces that we have in the Multi-Purpose Room. See page 11 for a further article on this event.

It truly was a special time here in Newark. Do not miss it next year. ♦

## HCA WELCOMES NEW MEMBERS FOR May 2009

John and Sheila Deming, MI  
Ray Ebersole, OK  
Mike and Paula Wolfe, PA

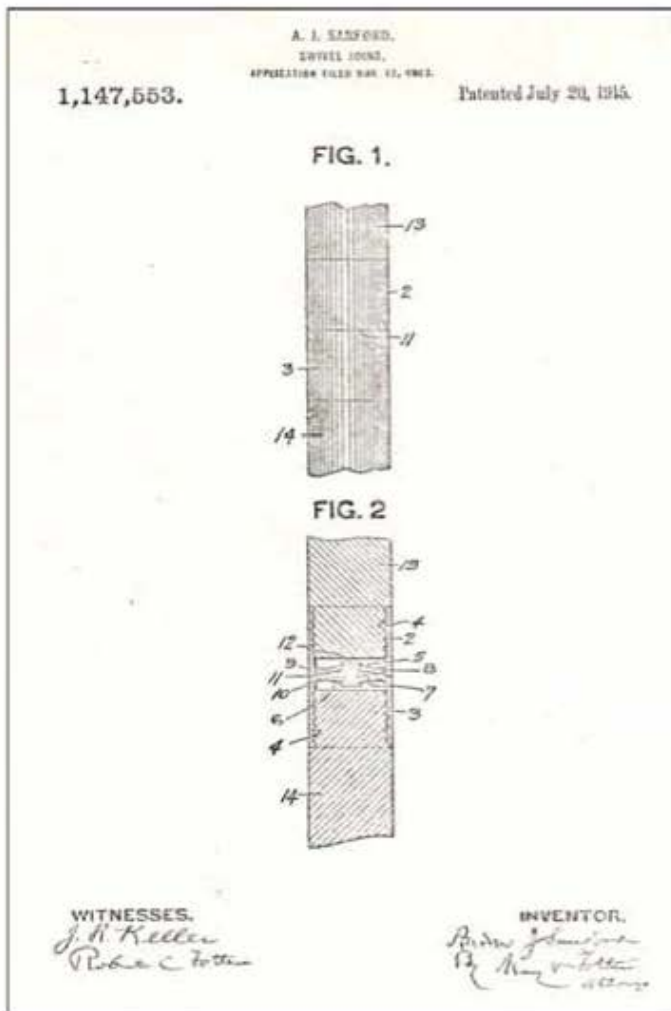

Patent 1,147,553

## UTILITY PATENTS ASSOCIATED WITH A.H. HEISEY & COMPANY (PART 5) Walter Ludwig

Our next series of utility patents will cover the years 1915 through 1918. The more important patents of this era cover Heisey's innovative electro-portable lamps. But first I want to correct a misstatement that I made in last month's article when I said that the records of utility patents for A. H. Heisey & Company end with the patents of 1917. I have now found in the Louise Ream Library a second volume of utility patents, so we are far from finished with these fascinating records of the company's innovations over the years. We will actually go to 1945 before we see the last of the Heisey

utility patents (and we will cover a related patent from 1949).

The first patent we will look at is number 1,147,553 granted on July 20, 1915, to "Andrew J. Sanford, of Newark, Ohio, assignor to A.H. Heisey & Co., of Newark, Ohio, a copartnership." This is the first patent in which we have seen the term "copartnership." Given the innovations of Andrew Sanford for the company, this is probably a way that the company offered him some recognition and the possibility of additional compensation for work that he did for the company. This invention could have been used by other companies and the agreement between Sanford and the company probably allowed him to earn some of the royalty payments from such use of the patent.

The illustration for this invention is one of the least understandable that we have encountered. The invention is listed as a "swivel-joint." The description of the invention says that it would be used to align two parts as in the case of a "candelabrum formed of glass or other material where the pedestal is fluted and formed in two parts, and it is desirable to have a connection which will permit of the parts being turned so as to bring the flutes or other figured in line with each other on the pedestal." If anyone has ever tried to put together a candelabrum from scratch, you could see where such a device could come in handy.

"The object of my invention therefore is to provide a joint which will be adapted for such and other purposes, and it consists, generally stated, in two ferrules or thimbles connected together with a flush joint and rotary the one with the others so that when used under the above conditions the pedestal into which one ferrule fits or the connection above into which the other ferrule fits may be turned to bring the flutes or other figures into register."

Unfortunately, I am not aware of any Heisey candelabrum that make use of such a mechanism to align the parts. It is possible that

the invention just was not cost effective to put into use.

would protect the inventor's rights if it was made use of in some other application.

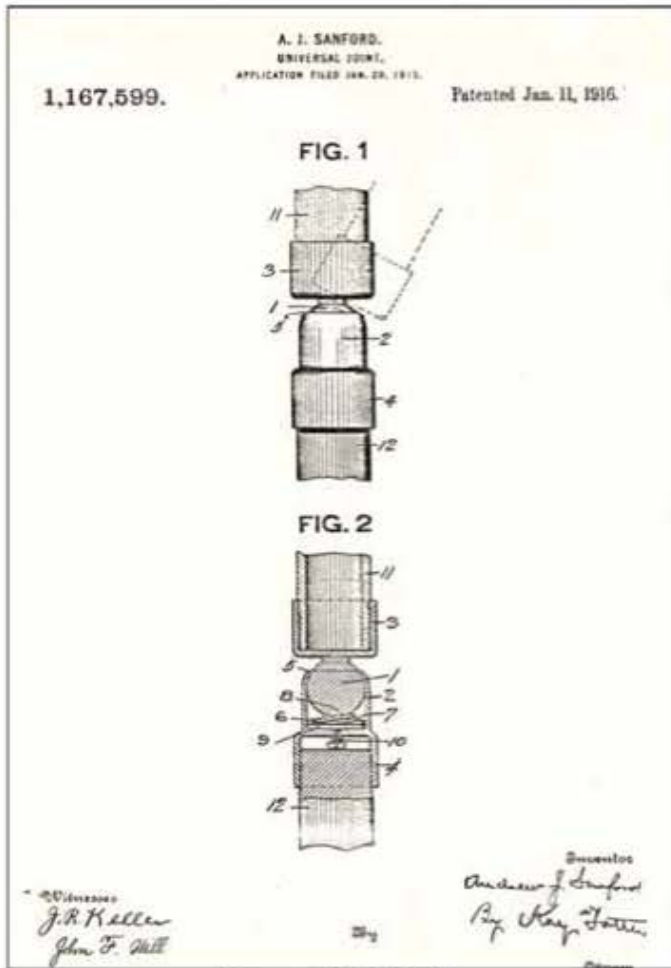

Patent 1,167,599

I will skip ahead to patent No. 1,167,599 which was granted on January 11, 1916 to Andrew J. Sanford assignor to A. H. Heisey & Company. This invention is described as a universal joint. I know of no application that this was applied to in the glass industry, but I am sure there must have been one. The description reads, "My invention relates to an improved universal joint construction, and is particularly concerned with a joint of this character in which provision is made for varying the friction between the members of the joint whereby the parts connected by the joint may be moved to and held in different relative positions by said friction action."

No doubt there was something at the factory that this was fabricated for and given that it was something new, a patent was applied for that

On June 14, 1913, Andrew J. Sanford (assignor to A. H. Heisey & Company, a copartnership) submitted four patents to cover the parts for what were to become Heisey's Electro-Portable lamps. The workings of the patent office must have been slowed by World War I, because the first of these patents was not granted until April 17, 1917. In the meantime, on September 16, 1914, a patent was applied for the lamp as a whole including shade and supporting apparatus. This one seemed to jump the line and was granted on August 17, 1915.

Patent No. 1,150,391 covered not only the hollow glass column used to support the electric lamp bulb but extended to the support for the shade and prisms that were hung from the support. As you know from the article in the January 2009 Heisey News, Heisey produced several different varieties of these lamps based on colonial style candlesticks that were in production at the time. Heisey also produced two different styles of supports for these lamps, glass and metal. The illustration for patent No. 1,150,391 is shown on the cover of this issue of the Newsletter.

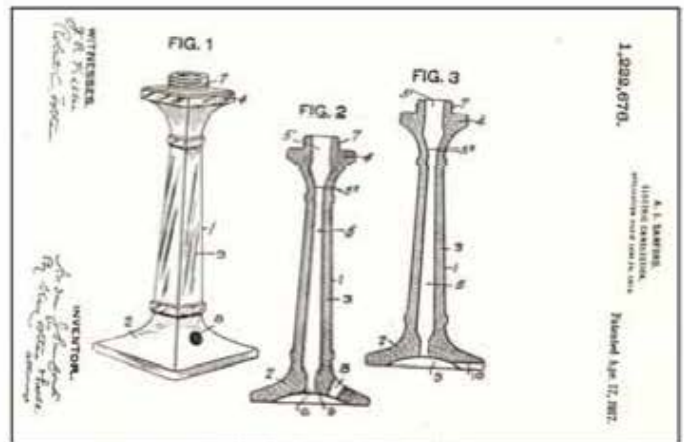

Patent 1,222,676

The other four patents deal more with the technical production of these lamp bases. Patent No. 1,222,676 is for an improvement in the production of an "Electric Candlestick." The candlestick produced would be hollow to allow

for the passage of the electric cord. Also, there would be a passage through the base of the candlestick so that the cord could pass safely to the outside without interfering with the stability of the candlestick.

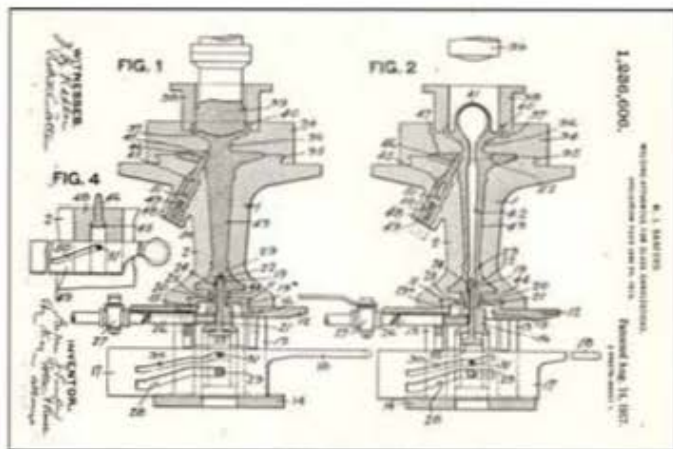

Patent 1,236,606 – Illustration 1

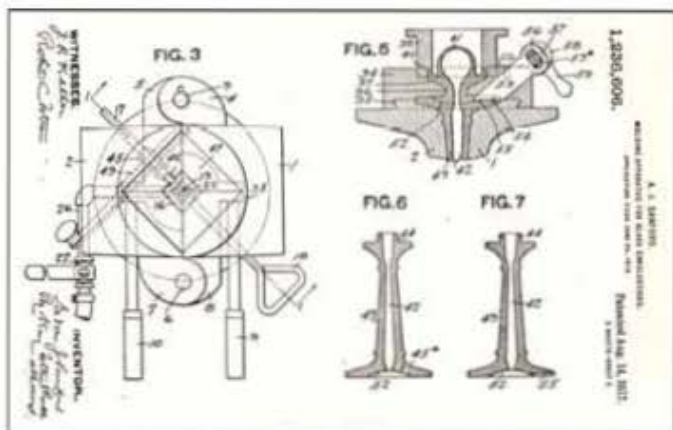

Patent 1,236,606 – Illustration 2

Patent No. 1,236,606 (granted August 14, 1917) deals with the molding apparatus needed to make these new types of candlesticks. The candlesticks are actually formed by “molding the exterior shape of the candlestick and while the article is still in the mold, blowing a passage longitudinally of the body of the article while the glass is still in a partially molten state and also forming a passage from the interior bore of the article to the outer surface through which the conductors may be readily threaded.” This provided a clean, quick process to make these lamp bases overcoming several of the drawbacks of earlier methods that were used to make similar articles.

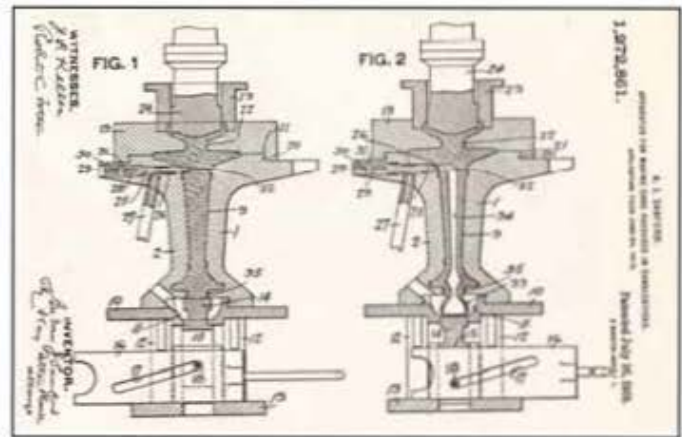

Patent 1,272,861 – Illustration 1

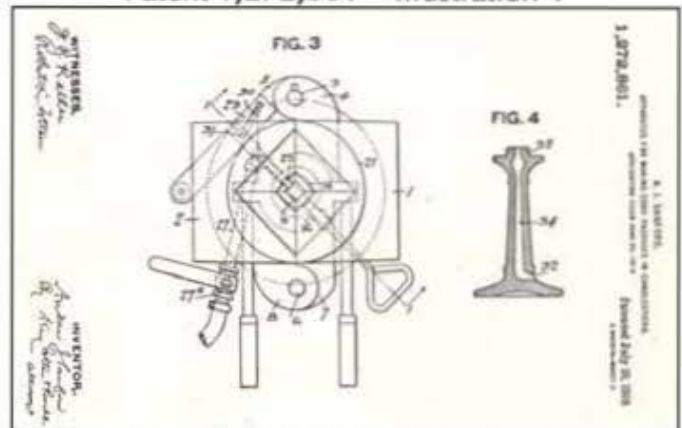

Patent 1,272,861 – Illustration 2

Patents Nos. 1,272,861 and 1,272,862 (both granted July, 16, 1918) dealt specifically with the making of the cord passage through the candlestick. The same illustrations were used for both of these patents. One of the obvious differences in this patent as opposed to No 1,236,606 is that the exit point for the cord is located at the base of the column rather than going through the bottom of the candlestick and then passing out through a separate hole in the base section.

Obviously, Heisey had a big hit with the Electro-Portable lamps that they produced in this period. Having patents on these inventions prevented others from copying Heisey’s innovations, thereby insuring that the company continued to prosper.

Next month we will cover more of the utility patents of A. H. Heisey & Company. Most of them will involve the actual process of making and finishing glass however. ♦



No. 464-8 in. Nappy  
Genuine Heisey

464 Puntty Row Nappy

## 464 PUNTY ROW

Joe Lokay

464 Puntty Row was a very short pattern of only two nappies, a 4 ½" and an 8" both with ground bottoms. This pattern was not included in Heisey Catalog #75 (1913), so it is estimated that production started after that catalog was printed, possibly in 1914. The nappies are pictured in Heisey Catalog #76 (1915). This catalog was a supplement to Catalog #75. In 1917, Heisey reused pattern number 464 for a fruit basket. Production of the 464 Lokay basket was from 1917-1925. Therefore, it is estimated that the production of the 464 nappies ended in 1916 giving the pattern a production life span of three years. I believe the nappies are signed with a Diamond H. No design patent application was filed for this pattern.

The design is a plain bowl with a row or band of punties around the bowl near the bottom. In the case of pattern 1220 Puntty Band, there is a sawtooth band above and below the punties. The band on 464 has a wave-like groove above it. These nappies may be rare; it is one of the few that the Museum does not have. Six of the small nappies and one large one would make up a berry set.

### Production pieces in 464 Puntty Row

1. nappy, 4 ½"
2. nappy, 8"

### References

1. Heisey Price List #175 (1913) p. 194
2. Heisey Catalog #76 (1915) p. 22
3. Vogel Book II, p. 172
4. Heisey News, August 1993, 464 Basket ♦



1254 Colonial Sherbet – Side and Top View



No. 1254-54 Oe.  
COLONIAL STRAIGHT



No. 1254-54 Oe.  
COLONIAL FLARED

1254 Sherbet – Straight and Flared  
(From Catalog #75 – 1913)

## 1254 SHERBET

Walter Ludwig

The 1254 sherbet pictured above was recently given to the Museum from a collector who has long been puzzled by this piece of glass. When it came to the Museum, I as well as everyone I showed it too was equally puzzled. You ask what could be so unusual about a sherbet that it would leave a person in a tizzy? From the side this looks like several other colonial sherbets that Heisey made. But when you look down into the bottom of the bowl of the sherbet, there is a little surprise. There you find a cone of glass rising a little over ½" from the bottom.

I did find the sherbet in Catalog 75 from 1913, and the picture sure does show this cone of glass. Now, I have gotten all kinds of suggestions as to what this might have been for, but none of them really hit the nail on the head. Was it to elevate a piece of cake that was then topped with chocolate? Maybe to elevate the ice cream so that the syrup could flow all around it? What is your idea about this interesting piece of Heisey glass? ♦



*A cooling drink seems even more sparkling and refreshing when served in this graceful pitcher and glass.*

## *Glass of exquisite cut design and so inexpensive!*



*On every  
piece*

Tracings as fine as the most delicate of Valenciennes lace, and patterns as painstakingly made, make the new pieces of Heisey glass *very* desirable!



*On every  
piece*

And they're so inexpensive to replace that you don't mind if they are fragile. You just use them every day and enjoy their beauty without worrying about how often they're used! If your dealer cannot supply you, order direct from A. H. HEISEY & CO., Dept. 40, Newark, Ohio



FOR THE TABLE

From Ladies' Home Journal, September 1919  
4163 Whaley Jug and 3476 Temple Ice Tea  
with 693 Cloister Cut



*A cologne bottle that adds to the attractiveness of any dressing table*

*No one denies the usefulness of any candy jar. And who could deny the prettiness of this one?*

*Your mirror itself doesn't hold any more beauty and grace than this little bottle!*

## For its beauty— and its usefulness!

For both its beauty and its usefulness, you'll like to own Heisey's graceful, sparkling glassware!

The new Heisey designs in glass for your dining table or your dressing table—in candy jar or cologne bottle—are unusually artistic and particularly well-made.

You'll be delighted to find, too, that these desirable pieces of Heisey's Glassware are very inexpensive. You'll enjoy using them every day! Heisey's Glassware is for sale only at the better stores. If your dealer cannot supply you, order direct from A. H. HEISEY & CO., Dept. 42, Newark, Ohio.



*On Every Piece*



*On Every Piece*



FOR THE TABLE

Ad Circa 1920, Probably Ladies' Home Journal  
490 Karen Cologne with 674 Adams Cut  
4291 Marlene Candy Jar with 680 Crusader Cut  
485 Hex Stem Cologne with 730 Cornflower Cut



Cutters and engravers – March 16, 1934

FRONT ROW - Bert Sheyon, Hohn Reed, Glenna Provin, Emil Krall,  
Francis Griffith, Bernard Klaus, and Oscar Krall (son of Emil, Sr)

BACK ROW – Franz Anton Krall (son of Willibald), Willibald Krall (Brother of Emil, Sr),  
Edith Bowman, Ed Lang, Estella Provin, Emil Krall, Jr, Arthur Kaercher, Emily Whaley,  
Howard Black, Henry Heller, William Weippert, Durward Acton, and "Shady" Gerould

## SPECIAL EXHIBIT – KRALL FAMILY GLASS

Walter Ludwig

One of the really special things that happened at Convention this year was a reunion of descendents of Willibald Krall. This came about through the work of William Krall who put together a loan exhibition of pieces that were still in the family's possession. All the pieces were expertly cut by Willibald for the use of his family. There are over 25 pieces presented from patterns like 1519 Waverly, 1540 Lariat, 1401 Empress, and 1509 Queen Ann as well as oil

bottles in 1184 Yeoman and 1489 Puritan. There are stemware pieces in 3368 Albemarle and 3411 Monte Cristo. The piece de résistance of the assemblage has to be a 4163 Whaley tankard exquisitely engraved with Willibald's signature Oriental cutting. All of the pieces are magnificent but the tankard is just breath taking. The beautiful oriental pagodas, the small figures, and the stunning waterfall and staircases truly attest to the artistry of the man. Even the handle of the pitcher is a work of art in that it also has been cut to match the scene.

When other members of the far-flung Krall family heard that the exhibit would be here at

the Museum, they made special arrangements to meet here during Convention. There were members from Ohio, Michigan, Wisconsin, and Illinois here to see and trade family stories that had been passed down to them. It was my privilege to meet with the family and share the information we have here on the Krall family.



**Willibald Krall Cut Pieces  
On Display in Museum Multi-Purpose Room**



**4163 Tankard with 6060 National Tumbler**

The exhibit will be here on view through the end of the year, so if you are in town plan to stop by. You may visit it either at the time of the October Select Auction (and Percy and Vivian Moore Dinner) or at our Holiday Open House in December.

One of the items I was able to share with the Krall family was the following article which Anton Krall (son of Willibald Krall) had sent to Louise Ream back in the 1970s. ♦

## **The Krall Glass Engravers: Their Life and Contributions to the Glass Industry** Anton Krall

The Krall family, its roots in the hilly soil of North Bohemia, eighteen miles from the German border, was one of many such families in that area of the glass industry during the nineteenth century.

For 25 miles inland of this former Province of Austria the inhabitants were of German stock who crossed from Germany, the mountains that ring the borders of Bohemia and Germany. The steady march of glass making from Italy to the north, eventually reached Bohemia where its prime forests provided abundant fuel for the ravenous appetite of glass furnaces. In later years, gas was extracted from the rich coal deposits in Bohemia to fuel the glass furnace.

Family records reveal that Joseph Krall, born 1848 in Arnsdorf, Bohemia (now part of Novy Bor, Czech Republic), was the first known glass cutter in the family. Like all glass workers in that town, he set up his foot power bench at home and contracted for work with a glass blowing manufacturer in nearby Haida.

He did the heavy type of glass cutting on stones and was known as an industrious worker. His career unfortunately was of short duration. He became tubercular and died in 1884, age 36. The widowed wife Johanna, with two daughters

and son, Willibald, was now left to support herself and her children. A few months after Joseph died, a second son, Emil, was born in 1884. Consequently, young Emil knew only about his father what the mother told him. The widow supported herself and family by selling notions in town and doing various work for the villagers. An accident caused her to lose her left eye. Henceforth, she walked about town with a black bandage over the lost eye.

Willibald, the older son was now 13 years and began apprenticeship with one of the senior glass engravers in town. The time required to serve as an apprentice was three to four years. The apprentice lived and boarded in the household of the master. Aside from his first attempts at engraving he earned his keep doing various chores about the house such as shining the family shoes, cleaning the engraving benches and running errands. There was no pay the first and second years except some tips for holidays and special occasions. The third and fourth year he was given a weekly allowance depending on his skill and industriousness. Toward the end of his last year, the apprentice engraved his master piece to prove his competence. He was now given a certificate stating that he served his apprenticeship and was now recognized as a journeyman glass engraver. He was now free to engrave as an employee to his master or to leave and seek his fortune in the outside world.

Most young engravers now wanted to spread their wings. They went to Prague, capital of Bohemia, or, more likely, to Vienna, the national capital of Austria. They obtained employment in one of several high class and sophisticated engraving shops that specialized in catering to the Royal Court of the Emperor Franz Joseph of Austria and to the aristocracy. The young engravers now enjoyed the many entertainments Vienna has to offer, tasted its famous wines and danced to the tunes of Johann Strauss waltzes.

Due to compulsory military training, they returned to their home town at age 20 to present themselves for examinations. If they passed the

physical, they were due for two years military service in the Austrian army.

After Vienna, Willibald engraved glass in Furth, Germany where he met his future wife, Babetta. In due time the son Anton was born in Furth 1898. Subsequently, Willibald moved his family to his home town Arnsdorf and set up his glass engraving bench.

Emil, the younger brother, followed the trend to Vienna after his apprenticeship. He was skilled to do special engraving for the Royal Court of the Hapsburgs and the royal families. After his stint of military service, he married a Vienna girl "Kathy" and established himself in his home town Arnsdorf for copper wheel engraving.

Eventually, Oscar, the first son was born in 1903 – destined to become a glass engraver in the new world of America. A daughter, Martha, was born in 1905 and Emil Jr. was born in Toledo on May 27, 1912. All went well until exciting stories of plush prosperity in America and a demand for skilled glass workers began to filter into Bohemia. At the same time ominous rumors and clouds of an impending war gathered over Europe.

After long deliberations and inquiries, it was decided the brothers Emil and Willibald would seek new fortunes and adventures in America. They would go to prepare the ground for a new life and temporarily leave their families to join them in America later. In April of 1907 the Krall brothers boarded a steamer in the busy port of Hamburg, Germany and crossed the Atlantic. One other engraver from Arnsdorf preceded them to Libbey Glass Co. Toledo, Ohio where they found immediate employment as copper wheel glass engravers.

In May of 1909 Emil's wife and children were the first to arrive in Toledo. Willibald's wife and family arrived in July of the same year. There now followed a period of wonder, excitement and adjustments to new environment, a new language and new friends. Ever restless and adventurous Emil, after some years at Libbey Glass, saw opportunities to strike out on his own

in the trend of light cuttings and engravings on glass tableware. He set up an engraving shop of his own and eventually had enough business to employ his brother Willibald and other engravers.

However, the glass cutting market fluctuated and suffered periodic declines. During one such decline, Willibald engraved glass at the Pitkin and Brooks glass cutting shop in Bowling Green, Ohio. Later the shop was consumed by flames and Willibald went to Corning, N.Y. to engrave for the J. Hoare & Co. cutting shop. Pitkin and Brooks in the meantime established a new cutting shop in Valparaiso, IN, to which Willibald and his son, Anton, returned. Due to some unsatisfactory conditions Willibald and family again returned to Toledo to engrave again for his brother Emil who, at that time employed four engravers, two cutters, and a polisher.

For a few years in the 1920s the DeVilbis Co. in Toledo featured engraved perfume and atomizer bottles. Also night lamps for dressing tables. These were of a milk glass over which were sprayed and fired in kilns successive layers of rose, green or yellow colors with black on the outside. Engravers cut through the different layers of colors to product beautiful scenes and figures when these lamp shades were lit up from an inside bulb. Anton and his cousin Oscar engraved at the DeVilbis plant for a few years while the trend or fad lasted. It was interesting work. Anton's brother Emil painted on the bottles in the decorating department where a number of china painters were employed. At home, Emil senior, also contracted with DeVilbis Co. during the busiest phase of the rush.

During the late 1920s the demand for engraved glass experienced a serious slump in Toledo and the Krall engravers again each went their separate ways. Willibald went to New York to engrave for Lison & Son. Anton went to Newark, NJ to engrave in a small cutting shop. Meanwhile Emil senior, at home, experimented with engraving on mirrors and contracted with interior decorators.

About 1925 Emil interested a mirror company in Cleveland in setting up an engraving shop. Again, the family clarion call was sounded and nephew Anton and a cousin Emil Bohmer responded. In 1926 Anton got married in Cleveland. However, he was not too happy with the work there and in 1927 moved to Chicago to engrave mirrors for the Atlas Glass-Mirror Co. which catered to the foremost interior decorators in the Chicago area. Some of Anton's engraved mirrors can be seen in the former Samuel Insull estate north of Chicago. After six years, and due to the depression period, this type of engraving also phased out. Certain acid and sand blasting processes cheapened mirror decorations.

In the late 1920s new management in the Libbey Glass cutting shop had taken over. There was a great rush of mass production of less expensive tableware on overhand lathes. The rush was so great that glass cutters worked in shifts. Along with several former copper wheel engravers, Anton joined the night shift having nothing else to do at the time.

In Cleveland, Emil Sr. became disenchanted with the mirror work and began to negotiate with the A.H. Heisey & Co. The company must have recognized the possibilities of stone engraving on copper wheel lathes when they engaged Emil as working manager of production. Emil brought with him his son Oscar and shortly called for his brother Willibald. Anton joined the shop in 1934. Once again, the Krall engravers were plying their trade under one roof.

As many times before, circumstances intervened that induced Emil Sr. to retire to the comfort of his home where he set up his engraving equipment to engrave glass for glass dealers. As the volume of business increased, his sons Oscar and Emil Jr. joined the venture.

At the Heisey engraving shop Willibald now was next in line to take over the duties of demonstrating Heisey glass engraving in stores where Heisey glass was sold. He continued in that capacity until he retired at age 76.

In 1938 Anton left Newark, Ohio to do copper wheel engraving for Steuben Glass, Inc., Corning, New York. Corning Glass Works had taken over the original "Steuben" founded by Fredric Carder and perfected a brilliant, colorless lead glass in its laboratory. New concepts in glass decorations required the services of expert copper wheel engravers. Occasionally, famous artists of America and Europe were commissioned to create special designs for Steuben glass.



Willibald and Emil Krall, Sr in 1955

In the 1950s, Emil Sr. retired to a small home in suburban Newark. He died after a serious illness in 1956. His sons Oscar and Emil Jr. continued in their own shop until Oscar also succumbed to illness. Willibald retired and settled in Marshfield, Wisconsin to be near his younger daughter of that city. He died of old age at 84 in 1956.

Anton continued at "Steuben" for twelve years. He lost his wife after a short illness in 1945. Due to a health problem he left Corning, NY in 1950 for a warmer climate in California. He continued engraving for several glass concerns in the Los Angeles area. Los Angeles Cut Glass Co., Dorothy Thorpe Inc., and Glendale and Kraft Glass Studio, Bell, CA.

Anton retired in 1963 in the city of Redlands, CA surrounded by the San Bernardino mountain range. ♦

## ANNUAL FINANCIAL REPORT TO MEMBERSHIP

Sharon Orienter, Treasurer

At the request of our new President and in an effort to make the financial business of HCA as understandable as possible I am trying out some new, streamlined financial reports. I hope you'll let me know if the information is easy to understand and if you have any questions.

At the Annual Meeting, I reported the following figures, from our form #990 filed with the IRS, for 2008:

We had total Revenue of \$242,221 and total expenses of \$199,364, for a net balance at the end of the year of \$42,857.

Average annual monthly cost of running the Museum/organization is \$16,613.67.

Our current (as of May 31, 2009) net assets are \$3,160,389. This includes bank accounts, Endowment Fund, inventory, property & equipment, molds, collection, archives, and library.

Our Endowment Fund at the end of 2008 was \$1,870,832.40. As of March 31, 2009 it was \$1,748,219.44. 2009 Endowment income is still projected to be \$71,000.

Net income from the Benefit Auction was \$15,248.49. Our net income from the Benefit auction was more than the budgeted amount of \$13,800 for which we must thank Dave Spahr's hardworking auction committee, all the consignors who sent beautiful glass, and the buyers who took it home with them.

At first glance, due to the excellent work of staff and volunteers alike and the exceptional leadership of our Convention Chairs, Mary Ann Spahr and Judy Rhoads, it looks like the Convention will be a financial success. I will

have more complete Convention numbers in the next Newsletter.

If anyone has any questions or would like more information and/or spreadsheets, please contact me by email: seo2@aol.com. ♦

## FINANCIAL REPORT TO MEMBERSHIP

Sharon Orienter

As of May 31, 2009, our year-to-date actual revenue was at 84% of budgeted, \$112,335.

This includes the net income from the Benefit Auction and the income from the Convention but not all of the expenses from the Convention, so I expect that percentage will drop and be more in line with expected. One of our best indicators, our membership fees collected, is right at 50%. Our revenue from Newsletter advertising is only slightly below where it should be and I'm sure we can find a space for anyone who would like to spend \$35 (per year) on being listed in the Dealer Directory section of the Newsletter. Our sales in the Gift Shop are much lower than we anticipated they would be at this time, so I'm hoping that we did well with sales during Convention and will continue to do so as the summer tour season continues. Our Museum admission fees are also slightly below expected but, again, this is only the beginning of our "high" season.

We have two major fund-raising events yet to go this year, the Percy & Vivian Moore weekend and the Select Auction. I hope all of you will attend these two events to make them successful. Last Year the Michigan study club hosted a tremendously successful Moore weekend and set the bar very high. Though we don't expect to do nearly as well at the Newark events, this year we need your support and attendance.

Year-to-date actual expenses are \$129,198.24, 65% of budgeted.

All of our expenses are at or below projected percentages except for a couple of categories in which our accountants and I are still working out some of our classifications. Please bear with us while we work through this process. Our Dues and Memberships and Advertising expenses are above projected but these are seasonal, not monthly expenses and will equalize.

Our monthly expenses continue to exceed our monthly revenue by an average of between \$3,000-4,000 per month and the 2008 income from the Endowment Fund is being used to pay those bills.

If anyone would like more information and/or spreadsheets, please contact me by email: seo2@aol.com. ♦

## HCA CONVENTION 2009 RECAP

Mary Ann Spahr and Judy Rhoads, Co-chairpersons

The weather was perfect, welcoming friendliness prevailed, the glass was sparkling and plentiful, and we were able to learn more about our beautiful Heisey glass. What can be more satisfying?

Although the numbers are not firm, we had approximately 175 registrants, including dealers. We welcomed eight first-timers this year, and had mentors available if they needed help, information, or a listening ear. Attendance was consistent at our Welcoming BBQ and at the Banquet. Our seminars on the etching process and Heisey's etchings in particular enhanced our Convention's educational mission. Our Hospitality Lounge welcomed weary conventioners, enticing them with delicious treats donated by our members. As well, this was also the gathering place for the Reunion of Former Employees, who are dwindling in numbers but are still gracious and enthusiastic.

The Study Club meeting, which was attended by twenty representatives of our study clubs, and our Annual Meeting, with an attendance of about seventy, provided an opportunity for all of us to reaffirm both our outreach and our connectedness with each other.

The Convention was a success because of the wide participation of so many of our members. Here is a list of many who generously helped make the Convention run smoothly:

## CONVENTION 2009 VOLUNTEERS

### HOSPITALITY ROOM DONORS:

*Chairs: Karen Clark, Pat Moore*

Dick & Marilyn Smith

HCA Club #16 Texas

Phil & Sally Abrams

Ned & Sibyl Lavengood

Central Illinois Heisey Club

Don Moore

Jim Clark

Linda Bischoff

Phyllis McClain

Great Plains Heisey Club

Earl & Elaine Hart

Elaine Husted

"The Virginia Group"

Walter Ludwig

Maxine Bartlett

Mac Otten

Lee Schwan

Jan & Ken Weber

Fred & Betty Pease

Karl Kolter

Gulf Coast of Florida Heisey Study Club

### SPECIAL AUCTION DONORS for BANQUET

*Chair: Charlene Bowman*

#7 Dayton Area Heisey Collectors Club

#8 Heisey Heritage Society

#13 Heisey Club of California

#14 Northern Illinois Heisey Club

#16 Heisey Collectors of Texas

#22 Northwest Heisey Collectors

#38 North Carolina Heisey Study Group

#52 Northern Virginia Heisey Study Club

Maezene & Jack Walker  
Darlene & Gordon Cochran  
Mary & Sid Edwards  
Bobbie & James Taylo  
Pat & Don Moore  
Mary Ann & Dave Spahr  
Trudy & John Mock  
Mary & Bob Kreimer  
Betty & Herb Wanser  
Pat & Rex Lucke  
Sally & Phil Abrams  
Karen Taylo  
Flo & Joe Harner

### REGISTRATION PACKET ASSEMBLY & DISTRIBUTION:

*Chair: Karen Taylo*

Elaine & Earl Hart

Mary & Sid Edwards

Sally & Phil Abrams

### BANQUET SET-UP & GREETERS:

Sue & Dan Kilgore

Marge & Jack Deppong

### MENTORS for FIRST-TIMERS

*Chairs: Sid & Mary Edwards*

Sally & Phil Abrams

Kathy & Tom Files

Glenn Gall

Mary Lou Dixon

Mahalah Harrison

Elaine Husted

Lee Schwan

### HCA BOOTH

*Chair: Robert Loch*

Joe Harner

Mac Otten

Pat & Robert Moreno

Sid Edwards

Tom Files

Karen Taylo

Ron Keener

Sue Kilgore

Jack Metcalf

Charlie Wade

### ID / SHOW & TELL PANEL

*Chair: Walter Ludwig*

Sharon Orienter  
Lynn Welker  
Susan Pescatore  
Joe Lokay

#### PUBLICITY

*Chair: Amy Jo Jones*

#### FORMER EMPLOYEES REUNION

*Chairs: Tom & Kathy Files*

#### HISTORIC HEISEY DRIVING TOUR:

*Chairs: Dick Marsh, Tom Heisey*

#### GLASS SHOW:

*Chairs: Sharon Orienter, Russ Reopell*

#### FLEA MARKET on the SQUARE

*Chair: Jeff Morrow*

Kim Carlisle  
Michael Maher  
Joey Cogdill  
Charlene Bowman

#### VOLUNTEERS AT-LARGE

Dave Spahr  
Ken Rhoads  
Charlie Wade

#### THANKS TO HCA MUSEUM STAFF

Walter Ludwig  
Justin Church  
Mandi McDonald

More information and pictures from Convention will be coming later. We received many helpful comments on the returned Surveys of Opinion. This is valuable information that will help us in planning next year's Convention. Your opinions were heard! Thank you for taking the time to give us feedback.

Plan now to attend Convention next year, and e-mail us if you have further suggestions or want to volunteer: Mary Ann at [masxenia@aol.com](mailto:masxenia@aol.com), or Judy Rhoads at [kjrhoads@aol.com](mailto:kjrhoads@aol.com). ♦

## HEISEY HOSPITALITY RECAP

## Karen Clark and Pat Moore

Thanks to all those who donated goodies and to those who took the time to visit the hospitality room on the lower level of the Museum during this Convention. I think that a wonderful time was had by all – as our Heisey collectors love to eat and some are really great bakers.

Prior to convention, Pat and I had taken inventory of plates, napkins, flatware, glasses, etc. and found enough in various nooks and crannies and determined that none of this needed to be purchased. As Pat and I went to the lower level on Thursday morning to “take stock” of what goodies we would be serving, we were in awe to find lunch meat, cheese, buns, nuts and more nuts, including beer nuts, peanuts and the famous pecans from Texas, homemade cookies (even one included the recipe) and crackers of many flavors. While we were taking stock, rolls of summer sausage appeared as well as more cookies, fresh fruit, nacho cheese dip and chips, bags of ice, “pop,” water and punch concentrate and mixer. Needless to say, we had worried and wondered for naught! We had been notified that several study clubs had made monetary donations to HCA to be used as needed for the hospitality room. Thanks to everyone's donations we had plenty of goodies for both Thursday and Friday. Some of the crackers, cookies, etc. were left on the table for members to enjoy on Saturday.

Several people expressed concern that Pat and I were confined to the lower level – not at all. We signed on to oversee the hospitality room – as it is always cool, no humidity, no rain, plus we just get to sit and visit with all who come down to rest awhile and eat. It is a great time to catch up on the happenings of the past year with the “old timers” and to talk as well with first time Convention attendees. This year was especially interesting as descendents of Willibald Krall brought in old photos, chalk drawings, and a cutting lathe (from Bohemia). They were happy to tell stories and share these items with all who were there. This was also a

reunion for them as well, as some had not met each other previously.

Another advantage of being in the hospitality room is the opportunity to talk with the dwindling number of former Heisey factory employees – such interesting stories they tell and all are happy to share their memories of the Heisey glass we all love. Even today as collectors we love to share our Heisey stories.

We will plan on seeing you next Convention in the lower level hospitality room. If you would like to join in the fun, just let us know. Thanks again to all those who donated and to those who came to enjoy the goodies. There would be no need for a hospitality room without all of you. Any comments or suggestions for next year, please contact me at karen9132@prodigy.net or Pat at pmoore42@columbus.rr.com.

Happy Heisey Hunting! ♦

## NEW REPRODUCTION HITS THE MARKET

Walter Ludwig

During Convention one of our members brought me a box and told me that he had recently bought the item as new from a retail establishment through the Internet. I was dumbfounded because the outside of the box showed an exact copy of a Heisey 461 Banded Picket basket. On the outside of the box it said “Shannon Crystal by Godinger: Colonial Crystal Basket.” An examination of the piece inside the box confirmed my worst fears. The reproduction is exact in almost every detail to Heisey’s basket. The measurements are the same. The differences come in the lack of the Diamond H trademark and the fact that the bottom is not ground. The glass is, of course, inferior to the fine crystal that Heisey made. There is waviness in the glass and small impurities are seen in the glass. This is only evident on close inspection, however. The glass also has a very high sheen to it.

Affixed to the bottom is a diamond shaped green sticker that reads, “Shannon Crystal, Designs of Ireland, Handmade Crystal, China.”



Shannon Crystal Box for Basket



Heisey Flamingo 461 Banded Picket Basket (left) and Shannon Crystal Basket (right)

I am told that these are being sold in places like Target and other retailers. The price usually is \$19.95. The design patent on the Heisey basket ran out long ago. They are not representing the basket as a Heisey product, but you need to be aware that this is now out there. If the price seems too good to be true, it probably is. ♦

# PICTURES FROM 2009 CONVENTION BARBEQUE



Heisey Collectors Are Always Ready to Eat



The Talk Is About Heisey, Of Course



And There Was a Good Selection to Drink, Too



It's a Time to Renew Heisey Friendships



Is This Line Getting Longer?



Heisey Friends Forever

# PICTURES FROM 2009 CONVENTION BANQUET



Convention Co-Chair Judy Rhoads  
Kicks Off the Event



Will She Get it?



Pre-Auction Inspection



Oh, Yes. It's a Prize



President Baker - Auctioneer Extraordinaire



Our Vanna's Displaying the Goods  
Mary Ann Spahr  
Kathy Smith  
Charlene Bowman



There Were Those There for the First Time



Your Curator with Friends



And Some that Have Been Here Many Times



All Awaited in Anticipation for the Outcome



The Great Plains Were Well Represented



The Lucky Bidder Admiring His Win



# HEISEY GLASS MUSEUM PLAYING CARDS

Edition 3 (green deck) of Heisey Glass Museum Playing Cards are now in. In addition, we have for sale a limited number of uncut sheets (21" x 25") which will be suitable for framing. This deck features the Heisey animals and animal related items. The full color pictures are stunning and will make a good learning tool as well as a nice gift for all of your glass collecting friends. We will ship as soon as available. Orders for Card Cases (Cobalt) and the Red deck may also be placed on this form.

Name \_\_\_\_\_  
 Address \_\_\_\_\_  
 City \_\_\_\_\_ State \_\_\_\_\_ Zip \_\_\_\_\_  
 Phone and/or E-mail \_\_\_\_\_

I wish to order:	Total
_____ (number) Heisey Glass Museum Playing Cards (Green) @ \$10 each	_____
_____ (number) Heisey Glass Museum Playing Cards (Red) @ \$10 each	_____
Shipping per deck \$ 1.50 (can be picked up at Gift Shop)	_____
_____ (number) Uncut sheets of Heisey Playing Cards (Green) @ \$25 each	_____
_____ (number) Uncut sheets of Heisey Playing Cards (Red) @ \$25 each	_____
Shipping per uncut sheet @ \$5.00 each (can be picked up at Gift Shop)	_____
_____ (number) 1508 Card case in Cobalt @ \$24.95 each	_____
Shipping per card case @ \$6.00 each (can be picked up at Gift Shop)	_____
<b>Grand Total (tax will be added when appropriate)</b>	_____

Check # \_\_\_\_\_ Visa \_\_\_\_\_ Master Card \_\_\_\_\_  
 Card Number \_\_\_\_\_ Exp \_\_\_\_\_

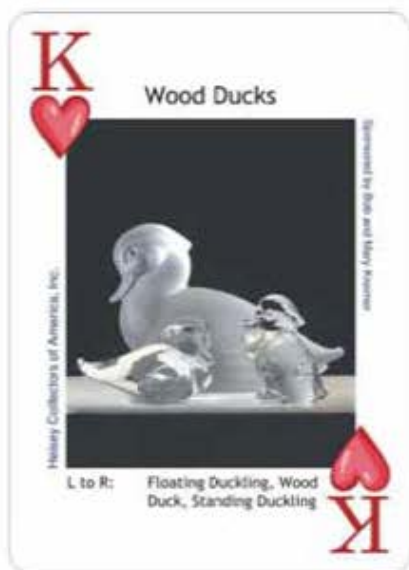
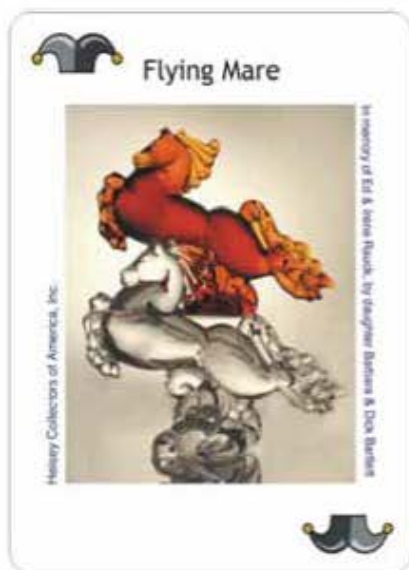

# Study Club Directory



Interested in joining a study club? You will have the opportunity to meet fellow collectors and HCA members and learn more about your favorite glassware. If your club is not listed or you need to make corrections to your listing, please contact the Museum.

STUDY CLUB	MEET WHEN?	WHERE?	Email/Web Site	CONTACT
#4 Central Illinois Heisey Collectors Club	Four times a year	Members' homes or restaurants		Joyce Deany (815) 432-4310
#5 Bay State Heisey Collectors Club	2 <sup>nd</sup> Tuesday of each month except July, Aug., and Dec.	Whole Foods Community Rm, Bedford, MA	spescatore@houghton.com	Stephen Pescatore (978) 256-5418
#7 Dayton Area Heisey Collectors Club	3 <sup>rd</sup> Tues. of the month Sept. to May, 6:30 p.m.	Huber Heights Library	LH937@aol.com	Joe Harner (937) 372-0852
#8 Heisey Heritage Society <i>NJ, Eastern PA and DE areas</i>	Four times per year	Members' homes	craigkratochvil@aol.com	Craig Kratochvil (973) 962-4004
#13 Heisey Club of California	4 <sup>th</sup> Sunday every month, 12:30	Members' homes	herbet@sbcglobal.net www.heiseyclubca.org	Norval Heisey (818)-349-0945
#14 Northern Illinois Heisey Club	Four times a year	Members' homes	niheisey@comcast.net	Jeff Morrow (630) 833-4644
#15 Heisey Collectors Club of Michigan	Every six weeks, August to May	Members' homes	kilgoredesigns@att.net	Sue E. Kilgore (269)-345-3990
#16 Heisey Collectors of Texas	2 <sup>nd</sup> Sat. of every odd month except May 1 <sup>st</sup> Sat., 1 p.m.	Members' homes	sanddollars97@tc.rr.com www.heiseycollectorsoftexas.org	Greg Freeman (817)-545-5889
#19 Heisey Collectors of the Rochester Area	10 meetings per year: Sunday, 2:30 p.m.	Members' homes	seo2@aol.com	Sharon Orienter (585) 288-8076
#20 Buckeye Heisey Collectors Club <i>Newark, OH area</i>	September to May, 4 <sup>th</sup> Monday	Members' homes or the Museum	Theflyingmaher@webtv.net	Michael Maher (740) 763-4256
#22 Northwest Heisey Collectors	First Saturday of the month	Members' homes	bahama50@hotmail.com	Deborah de Jong (425) 868-0457
#25 Heisey 76'ers <i>Columbus, OH area</i>	Once a month, September to May	Members' homes	ldburg48@aol.com	Colleen Burgess (614) 882-1884
#31 Nassau Long Island Heisey Club	Generally every other month	Members' homes		Babs Kent (516) 228 8274
#32 Dairyland Heisey Club	Once every two months	Members' homes		Ray K. Courtneage (414) 962-9747
#33 Golden Gate Heisey Collectors Club <i>Northern California</i>	Quarterly	Members' homes		Russ Nicholas (916) 515-8558
#36 Heisey Club of Southern MA	April, June, September, December			Maria Martell (508) 833-0633
#38 North Carolina Heisey Study Group	6 meetings per year: Jan.; March, May, July, Sept., Nov.	Replacements Ltd Greensboro, NC	Nchsg@yahoo.com www.northcarolinaheiseystudygroup.org	Karen Taylo (252) 637-9985
#39 Florida Heisey Collectors Club	4 times per year: January – February-March-April	Westchester Country Club Boyton Beach, FL	Shirley400@aol.com	Everett Dunbar (772)-337-1558
#42 Gulf Coast Heisey Club of Florida	Nov., Jan. and March; 2 <sup>nd</sup> Thursday 11:00 am	Members' homes		Jack Grenzebach (727)-391-5784
#43 Tri-State Heisey Study Club <i>OH, IN, MI</i>	1 <sup>st</sup> Sat. every 3 <sup>rd</sup> month	Members' homes	Maxwellm@cktech.biz	Mike Maxwell (260) 925-3484
#45 Hoosier Heisey Club	Four times a year	Warren Library, Indianapolis, IN		J. David Litsey, (317) 872-7800
#48 Dixieland Heisey Study Club	Odd number months, 2 <sup>nd</sup> Saturday night	Members' homes	www.dixielandheisey.org	Craig German (770) 967-8733
#49 Great Plains Heisey Club	March, May, July, September, and November	Members' homes	cameron_mg@mchsi.com www.greatplainsheiseyclub.org	Mary Cameron (515) 292-3743
#50 Northwoods Heisey Club of Minnesota	Four times a year	Members' homes	wheise@comcast.net	Bob Heise (952)-831-9335
#51 Heisey Club of Northeast Florida	Feb., May, Aug., and Nov. 2 <sup>nd</sup> Thursday	Avonlea Antique Mall, Jacksonville	Clasyglas2@aol.com	Barb Bartlett (904) 280-0450
#52 Northern Virginia Heisey Study Club	Monthly, Sept. – May	Members' homes	rreopell@verizon.net	Russ Reopell (703) 250-6117



## CLUB NOTES

Northwoods Heisey Club of Minnesota  
*Ann Moll*

Thirteen members of the Northwoods Heisey Club gathered for our May 2 meeting at the home of Carole and Gordon Olsen. All were eager for the final event of the day, our annual raffle and auction to raise funds for HCA.

Before the event began, dues were collected; the minutes of the last meeting and the treasurer's report were approved. Discussion revolved around the September display of Heisey at the Edina Senior Center, and the possible site of our next meeting, which will be on Saturday, August 29 at 1:00 p.m. Members will be notified of the determined location. Carole Olsen will present a program on Krall and his cuttings.

Gordon and Carole Olsen plan to attend the Heisey Convention in Newark, Ohio, from June 17 – 20. The membership approved Carole as our Club voting representative.

Elections were held for a 2 year term and these nominations were approved: Carole Olsen as President, Ann Moll as Secretary, and Bev Heise as Treasurer.

Preceding the raffle and auction, Virginia Johnson presented a program on Heisey Decorations, sharing information and a two page listing of Heisey decoration patterns and their numbers. Marv Christensen shared a small stemmed Colonial pattern piece resembling a favor vase, or perhaps a violet vase.

Ann Moll was the winner of our raffle which was a 1469 Ridgleigh two light candelabra donated by the Olsens. The auction, conducted by Bob Heise, began with a Pheasant, followed by these items: 1488 Kohinoor floral bowl, 1503 Crystolite candlesticks, Yeoman stemmed bowl and the January issue of "Cooking with Paula Deen" which featured a story on the Heisey 1567 Plantation

pattern, Flamingo celery/relish dish, 1401 Empress cup/saucer and salad plates, crystal mustard with cover, 1469 Ridgeleigh vase, 335 Prince of Wales Plumes half-gallon jug with stuck handle, Hawthorne 1229 Octagon 6" mint, 1497 Boat floral bowls, 337 Touraine compote with candy to "sweeten the pot," 1506 Whirlpool (two creamers and 1 sugar), six Colonial sherbets, and concluding with a 503 Minuet etched celery dish. Our auction and raffle yielded \$995, which will be rounded off to \$1000, and sent to HCA. It was voted to divide the amount with half to the Endowment and half to operating

The afternoon ended with stimulating conversation and refreshments served by the Olsens. A delicious punch was served from a 1567 Plantation punch bowl in Plantation punch cups. A strawberry cake, with fresh strawberries was the dessert. ♦

### Advertising Guidelines:

Advertising: Ads may be mailed to: HCA Advertising, 169 W. Church St., Newark, OH 43055; faxed to (740) 345-9638; or e-mailed to [curator@HeiseyMuseum.org](mailto:curator@HeiseyMuseum.org). Whenever possible, please e-mail your ad. Include your MasterCard or VISA number and expiration date for billing purposes, or send a check. All ads must be prepaid. When mailed or faxed, ads should be typed or printed on white paper with dark ink. Please double space. Ads that are entered in a vertical column format may contain a maximum of 65 characters per line, including spaces & punctuation.

Classified: 20 cents per word (members), 30 cents per word (non-members), \$1.50 min., 1/8 page limit. Personal ads 1/8 page limit. Abbreviations & initials count as words.

Display Ads:	member	nonmember
1/8 page (12 lines)	\$ 20	\$ 30
1/4 page (25 lines)	\$ 40	\$ 60

1/2 page (60 lines, horizontal or vertical)	\$ 80	\$120
Full page (120 lines)	\$160	\$240

A charge of \$1.60 will be added for each additional line.

1/2 page: 4 1/2" high by 7 1/2" wide or 9" high by 3 1/2" wide

Full page: 9" high by 7 1/2" wide

Ad copy must be received by the first of the month prior to publication. Reproductions (i.e., Heisey by Imperial) must be indicated. Heisey News accepts no further liability. In the event of a typographical error, the incorrect portion of the ad will be run in the following issue, but HEISEY NEWS assumes no further liability.

**Abbreviations:** DF = Dolphin Foot NO = Narrow Optic  
DO = Diamond Optic SO = Spiral & Saturn Optic  
MO = Medium Optic WO = Wide Optic

### Classified Ads

Nick Maglio  
1130 Savannah St. SE  
Palm Bay, FL 32909

(321) 674-9732  
heiseyguy1@wmconnect.com  
USPS Extra

4230 Favor vase Moongleam	\$650
1280 Winged Scroll spoon, fair gold, Emerald	120
1280 Winged Scroll cream, fair gold, Emerald	120
479 Petal sugar and cream, Flamingo	250
1252 Twist pickle, 7", Marigold	75
1255 Pineapple & Fan hotel cream & sugar, Emerald	275
3404 Spanish soda, 12 oz, Cobalt	175
1405 Ipswich soda 8 oz, Sahara	75
479 Petal sugar Moongleam	125
1401 Empress nut, D/F (4 each)	25
1425 Victorian sherbet, 5 oz (4 each)	25
1405 Ipswich soda, 8 oz	25
1401 Empress relish, 7" triplex, Sahara	60
1469 Ridgeleigh candlesticks, 2" square, pr	75
335 Prince of Wales Plumes finger bowl, straight	55
1503 Crystolite conserve, 2 compartment, ctr hdl	75
1503 Crystolite salad dressing, crimped	35
1503 Crystolite punch cups (8 each)	12
1184 Yeoman cup/saucer Hawthorne	75
1469 1/2 Ridgeleigh relish, 2 part, 7"	50
433 Greek Key plates, 6 1/2" (3 each)	50
300 Peerless jelly, low, 5 1/2"	40

◆ *Paid Ad*

## Find the Best of Heisey Glass...

...with popular patterns like Orchid, Heisey Rose, Minuet, and hundreds more. We also carry other fine crystal and depression glass from Cambridge, Fostoria, Imperial, Duncan & Miller, and more. The world's largest supplier of old and new china, crystal, flatware and collectibles, Replacements, Ltd. carries over 11 million pieces in inventory in over 250,000 patterns.

If you're looking to add to your collection, or if you're looking to sell — call us toll-free. We're always looking for more.

 **REPLACEMENTS, LTD.**  
China, Crystal & Silver • Old & New  
Dept. HS, PO Box 26029, Greensboro, NC 27420  
[www.replacements.com](http://www.replacements.com)

**1-800-REPLACE (1-800-737-5223)**

◆ *Paid Ad*

## REAL HEISEY IN THE GIFT SHOP

All crystal and all prices are each unless noted.

Supply changes daily. Please contact the Gift Shop before placing an order.

Item	Price
134 Trident 2 lt candlesticks, silver overlay, pr	\$40
150 Banded Flute punch cups, H (6 each)	7
337 Touraine wine, H (2 each)	10
343 Sunburst butter top only H	25
350 Pinwheel & Fan punch cups, H (2 each)	10
351 Priscilla butter pat, H	10
394 Narrow Flute 4 1/2" chow chow, H	25
394 Narrow Flute salted nut, H	10
411 Tudor cruet, H	35
411 Tudor punch cup, H (2 each)	5
475 Narrow Flute/Rim salted nut, plain bottom H	15
500 Octagon tray, 6", Moongleam	10
1183 Revere individual salt (4 each)	12
1184 Yeoman cocktail, H	10
1184 Yeoman goblet, H, Flamingo	30
1205 Fancy Loop individual cream, Emerald	40
1225 Plain Band table sugar lid	15
1252 Twist mint, H, Marigold	20
1252 Twist cheese plate, H, Marigold	20
1295 Beaded Swag nappy, 4", Emerald	20
1401 Empress plate, 8" sq, 448 Old Colony, Sahara, H (4 each)	15
1404 Ipswich sherbet (2 each)	10
1469 Ridgeleigh mustard, H	46
1483 Stanhope cream/sugar, no knobs, H	30
1483 Stanhope cup, no knob (6 each)	15
1503 1/4 Crystolite sq candleblocks, pr	25
1509 Queen Ann DF creamer	5
1519 Waverly pickle/olive	10
1519 Waverly plate, 8" (2 each)	5
1519 Waverly 10" deep salad bowl	15
3362 Charter Oak finger bowl, blue/gold stain	10
3440 Portsmouth goblet, Moongleam ft (3 each)	20
4085 Kohinoor oyster cocktails, ftd (6 each)	5
4085 Kohinoor sherbets (2 each)	5
4085 Kohinoor soda, 10 oz	8

### NEW IN THE GIFT SHOP

Reprint of Catalog and Price List No. 31,  
September, 1950 \$12.95

Heisey Placemats (produced by Bay State Heisey Club)  
\$14 each or 2 for \$25

Heisey Notecards, 12 cards each with a different Heisey  
etching plus envelopes \$12

◆

# Dealer Directory

Maximum 6 lines/12 months/\$35 MEMBERS ONLY

Contact the Editor to place your ad!



<p><b>KIM &amp; PAM CARLISLE</b> SHOWS &amp; MAILORDERS ONLY 28220 Lamong Rd. Dept. H Sheridan, IN 46069 Glass Cleaning Services Available (317) 758-5767 <a href="mailto:kcarlisl@worldnet.att.net">kcarlisl@worldnet.att.net</a></p>	<p><b>SHIRLEY EUGENIA DUNBAR</b> Heisey a Specialty—Mail Order, Shows, Appraisals EMAIL: <a href="mailto:shirley400@aol.com">shirley400@aol.com</a> PO Box 8344, Port St. Lucie, FL 34952 Oct-May (772) 337-1558 PO Box 222, Naples, ME 04055 May-Oct (207) 642-5652</p>	<p><b>SUM OF LIFE</b> Elaine Husted: 610-469-1243 Traveling through eastern PA Call, stop in, be a buyer or a browser! E-mail: <a href="mailto:1classycat@comcast.net">1classycat@comcast.net</a></p>
<p><b>ALL HEISEY AUCTION</b> Consignments Welcome Apple Tree Auction Center 1616 W. Church, Newark, OH 43055 (740) 344-4282</p>	<p><b>MOUNDBUILDERS SECOND GENERATION</b> Barbara and Richard Bartlett Heisey Exclusively! 1-904-280-0450 PO Box 1931, Ponte Vedra Beach, FL 32082 Toll Free 1-888-434-7397/(HEISEYS) EMAIL: <a href="mailto:CLASYGLAS2@AOL.COM">CLASYGLAS2@AOL.COM</a></p>	<p><b>EAGLES REST ANTIQUES</b> Buying Heisey, China &amp; Pottery Carl and Mary Evans 62 Fieldpoint Rd., Heath, OH 43056 (740) 522-2035</p>
<p><b>PAULA &amp; JEFF MORROW</b> Elegant Glassware and American Dinnerware 126 Clinton Avenue Elmhurst, IL 60126 (630) 833-4644 <a href="mailto:mor-fab@comcast.net">mor-fab@comcast.net</a></p>	<p><b>H &amp; R DIAMOND H</b> Helen &amp; Bob Rarey 1450 White Ash Dr. Columbus, OH 43204 (614) 279-0390 after 5:30</p>	<p><b>CRYSTAL LADY</b> Bill, Joann &amp; Marcie Hagerty Specializing in elegant depression glassware 1817 Vinton St., Omaha, NE 68108 Shop (402) 341-0643 or Home (402) 391-6730 Email: <a href="mailto:ejhagerty@aol.com">ejhagerty@aol.com</a> website: <a href="http://www.crystalladyantiques.co">www.crystalladyantiques.co</a></p>
<p><b>REALMS IN GLASS</b> Roy Eggert Heisey Custom Stained Glass 9423 Saddlebrook Ct, Frederick, MD 21701 301-260-0234 <a href="mailto:roy54@hughes.net">roy54@hughes.net</a></p>	<p><b>PIECE BY PIECE ANTIQUES</b> Buy &amp; Sell Specializing in Heisey Glassware Bryan K. Baker Fairfax Station, VA 22039 Newark, OH 43055 (703) 250-6117 <a href="mailto:piecebypiece@verizon.net">piecebypiece@verizon.net</a></p>	<p><b>PATTON HOUSE ANTIQUES</b> Specializing in Glass*Heisey*Cambridge*Fostoria*Duncan* Factory Antique Mall, Verona, VA off I-81 Exit 227 Antiquers Mall, Booth 81, Rt. 29 N., Charlottesville, VA The Daniels, Box 547, Louisa, VA 23093 (540) 967-1181</p>
<p><b>C&amp;J ANTIQUES</b> Cole &amp; Jean Miesner Box 45, 72 Whig St. Newark Valley, NY 13811 (607) 642-9905</p>	<p><b>SIBYLS OF WILMINGTON</b> Sibyl &amp; Ned Lavengood at Castle Corner Antiques 555 Castle St. Wilmington, NC (910) 264-9597 or <a href="mailto:Sibylsantiques@bellsouth.net">Sibylsantiques@bellsouth.net</a></p>	<p><b>FRAN'S FANCY FINDS</b> Fran &amp; Jack Grenzsbach 10534 Valencia Rd., Seminole, FL 33772-7511 (727) 391-5184 SHOWS MAIL ORDERS</p>
<p><b>The American Bell Association</b> P.O. Box 19443 Indianapolis, IN 46219-0443 <a href="http://www.americanbell.org">www.americanbell.org</a> m</p>	<p><b>PASTICHE ANTIQUES</b> at Preston's Antique Gaslight Village US 12, Allen, MI 49227 Elegant Glass and Other Fine Antiques <a href="mailto:pasticheantiques@gmail.com">pasticheantiques@gmail.com</a></p>	<p><b>WILLEY'S ANTIQUES &amp; MUSEUM</b> Specializing in Heisey 11110 Cannon Rd., Frazeyburg, OH 43822 16 miles east of Newark, OH (740) 828-2557</p>
<p><b>CHARLES &amp; MILDRED FISHER</b> Heisey animals and Heisey By Imperial animals 1607 Dayton Rd, Newark, OH 43055 <a href="mailto:Cfisher0@roadrunner.com">Cfisher0@roadrunner.com</a> (740) 281-3104</p>	<p><b>MARSH'S ANTIQUES</b> Dick and Virginia Marsh 4532 Newton Road Newark, OH 43055 <a href="mailto:vwamp@afalink.com">vwamp@afalink.com</a> (740) 366-5608</p>	<p><b>MOONGLEAM ANTIQUES</b> Heisey Glassware &amp; American Art Pottery John Woytowicz and Peter Rivard 70 Pleasant St., Gardiner, ME 04345 (207) 582-9048 E-mail: <a href="mailto:jmwpwr@aol.com">jmwpwr@aol.com</a></p>
<p><b>ROBERT M. LOCH</b> Voting Member HCA and NWHC Pacific Interstate Glassware Co. PO BOX 469 Custer, WA 98240 360-366-3166</p>	<p><b>CRESTONE MANOR UNIQUES</b> Harold &amp; Loleta Hammontree 3317 Crestone Circle, Chattanooga, TN 37411 423-629-1274 <a href="mailto:hammonl@bellsouth.net">hammonl@bellsouth.net</a> Heisey Only</p>	<p><b>APPLE VALLEY COLLECTIBLES</b> Richard &amp; Marilyn Garnett - Owners Shows/ Mail Order (845) 691-6308 Email: <a href="mailto:diamond195@aol.com">diamond195@aol.com</a></p>
<p><b>DOWNSTAIRS AT FELTON ANTIQUES</b> 100B Felton St, Waltham, MA 02453 781-894-2223 <a href="mailto:info@feltonstreetantiques.com">info@feltonstreetantiques.com</a> GLASSWARE, POTTERY, EPHEMERA, STERLING, FURNITURE FROM EVERY DECADE!</p>	<p><b>WM GLASS</b> Bill &amp; Mary Barker 400 Nantucket Ave., Pickerington, OH 43147 (740) 927-0918 <a href="mailto:mcbarker@embarqmail.com">mcbarker@embarqmail.com</a> Heisey Only</p>	<p><b>WATERSEdge ANTIQUES</b> Norene &amp; Don Walzer Shows &amp; Mail Order 25089 Riverwalk Drive Leesburg, FL 34748 (352) 314-8975 <a href="mailto:dnnwalzer@embarqmail.com">dnnwalzer@embarqmail.com</a></p>
<p><b>JERRY'S ANTIQUES</b> Shows Only Glassware and Other Fine Collectables PO Box 4485, Davenport, IA 52808 563-340-1871 <a href="mailto:jerrysantiques@mchsi.com">jerrysantiques@mchsi.com</a></p>	<p><b>ONCE AND FUTURE ANTIQUES</b> Susan &amp; Stephen Pescatore 9 Donna Rd. Chelmsford, MA 01824 (978) 256-5418 Heisey and Elegant Glass</p>	<p><b>BOB &amp; MARY KREIMER</b> Specializing in Heisey Glass 7044 SW 116<sup>th</sup> Loop, Ocala, FL 34476 (352) 873-8306 email: <a href="mailto:rkreimer@earthlink.net">rkreimer@earthlink.net</a>. Shows and Mail Orders Only</p>
<p><b>J &amp; L TREASURES</b> Specializing in Heisey, Cambridge, Fostoria, Tiffin, Morgantown, etc Linda Kilburn, PO Box 1257, Burlington, CT 860-673-4088 <a href="mailto:jltreasures@comcast.net">jltreasures@comcast.net</a></p>	<p><b>Charlene Bowman</b> Shows Only Heisey - Cambridge - Fostoria - Morgantown P.O. Box 287, Clarksville, OH 45113 937-289-2114 <a href="mailto:twoclbs@aol.com">twoclbs@aol.com</a></p>	<p><b>YELLOW BRICK ROAD ANTIQUES</b> Jean Will Leavenworth, KS 66048 (913) 682-4831 Specializing in Heisey and Elegant Glassware Shows and Estate Sales</p>
<p><b>Just in Time Antique Mini Mall</b> 29 North Third St Newark, OH 43055 Heisey in Stock 740-349-0001 <a href="mailto:ntleblanc@aol.com">ntleblanc@aol.com</a></p>	<p><i>Your Ad Could be Here</i></p>	<p><i>Your Ad Could be Here</i></p>

## When Renewing Your Membership

Help ensure the future of your Museum. When you renew your membership at one of the levels below, any amount beyond the regular Associate dues goes into the Endowment Fund.

<i>Individual Contributing, one person in household</i>	<i>\$50</i>
<i>Joint Contributing, two people in one household</i>	<i>\$60</i>
<i>Family Contributing, parents and children under 18</i>	<i>\$75</i>
<i>Patron</i>	<i>\$125</i>
<i>Sponsor</i>	<i>\$250</i>
<i>Benefactor</i>	<i>\$500</i>

Visit The  
National  
Heisey  
Glass  
Museum



Come at your leisure to enjoy more than 4,800 pieces of glassware produced by A.H. Heisey and Company from 1896-1957. Hundreds of patterns are featured in all production colors. Rare and experimental items are included as well.

Facilities are air-conditioned and handicapped-accessible. Hours are 10:00 a.m. to 4:00 p.m. Tuesday through Saturday, 1:00 to 4:00 p.m. Sunday (except Jan. and Feb.). Members are admitted free, regular admission is \$4. Office hours are 8:00 a.m. to 4:30 p.m. weekdays.

**Membership Renewal Notice:** Check the date above your name and address on the mailing label. This is your expiration date. If it reads 7-10-09, make sure your dues are paid soon in order to receive next month's issue of *Heisey News*.

Contact the HCA Administrative Office at (740) 345-2932 for more information. The Endowment Committee wishes to thank those who have become Endowment Members and all of the individuals and study clubs that have so generously supported the HCA Endowment Fund. All members who have supported the fund are recognized each year in the February issue of the Newsletter. Your support will make the Museum self-sustaining in the years to come. Thank You all! ♦

### Shipping & Handling Fees for Outside US

Additional shipping charges are required for members living outside the U.S. Current rates are Canada, \$22; for other countries, contact the Museum. Rates are subject to change at any time due to rate changes made by the US Postal Service. To verify current rates, call (740) 345-2932 or E-mail [business@HeiseyMuseum.org](mailto:business@HeiseyMuseum.org)



### Periodical Postage

Paid at the Post Office  
In Newark, OH 43055  
Publication # 00986  
POSTMASTER SEND FORM 3579 TO:  
HCA  
169 W. Church St.  
Newark, OH 43055

To: \_\_\_\_\_

## Museum Volunteers for May 2009

Chuck & Amy Jo Jones

Frank Kuhlmann

Dick Marsh

Phyllis McClain

Don & Pat Moore

Sharon Orienter

Ginny Priest

Russ Reopell

Judy Rhoads

Dick & Marilyn Smith

Dave & Mary Ann Spahr

Charlie & Susan Wade

Micki Wareham