

HEISEY NEWS

The Official Publication of Heisey Collectors of America, Inc.

Volume XXXVIII No. 4

April 2009

ISSN 0731-8014

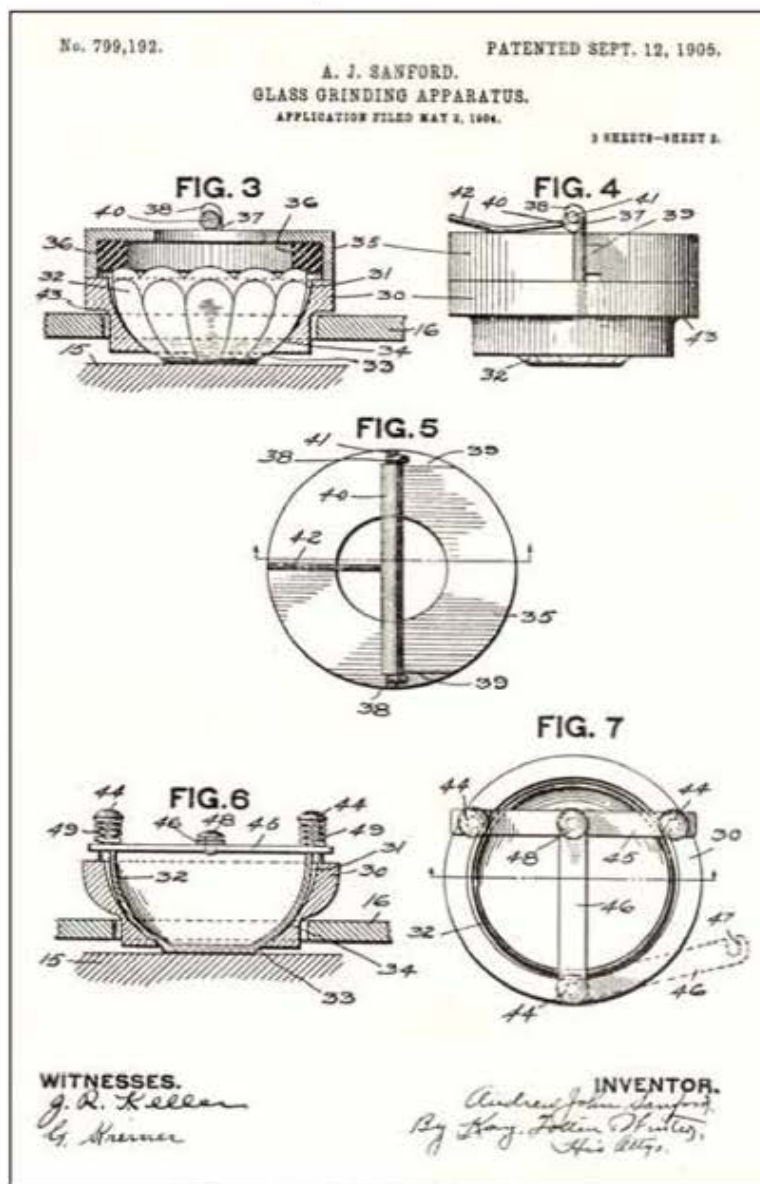

Patent 799,192 – Illustration 3

Read More about A. H. Heisey Utility Patents on Page 5

HEISEY NEWS

Heisey Collectors of America, Inc.
169 West Church Street
Newark, Ohio 43055
Phone 740-345-2932 Fax 740-345-9638
Web Site: www.heiseyMuseum.org
All Rights Reserved 2009
ISSN 0731-8014

Staff and Phone Extensions

Curator, Walter Ludwig, curator@heiseyMuseum.org, Ext. 4
Clerks, Justin Church, Amanda McDonald
membership@heiseyMuseum.org, Ext. 1
Gift Shop, Ext. 5

HCA Board of Directors:

President, Bryan Baker - Fairfax Station, VA, 703-250-6117 -
hcapresident@heiseyMuseum.org
Vice-President, Charlie Wade - Newark, OH 740-587-2002
Secretary, Amy Jo Jones - Beavercreek, OH, 937-426-1567
Treasurer, Sharon Orienter - Rochester, NY, 585-288-8076
Member-at-Large, Dave Spahr - Xenia, OH, 937-372-7166

Sid Edwards - Tallahassee, AL, 334-283-4663
Tom Files - Kansas City, MO, 816-468-7087
Ron Keener - Heath, OH, 740-323-3747
Sue Kilgore - Kalamazoo, MI, 269-345-3990
Robert Loch - Custer, WA, 360-366-3166
Jack Metcalf - Utica, OH, 740-892-2664
Karen Taylo - New Bern, NC, 252-637-9985

HEISEY NEWS is published and printed monthly (twice in March), by Heisey Collectors of America, Inc. (HCA). Periodical postage paid at Newark. Subscription is limited to HCA members. First class mailing is available for an extra \$20.00, due with payment of membership. If you are having difficulty receiving your Newsletter, please contact the HCA Administrative Office Monday through Friday 8:30 a.m. - 4:30 p.m.

The opinions expressed in articles in HEISEY NEWS are those of the authors and not necessarily those of the organization. The Editorial Staff reserves the right to edit, with or without the consent of the author or to refuse any material submitted for publication.

Back Issues

Back Issues available from files are \$3.00 per issue plus shipping and handling

Advertising

Ads may be mailed to: HCA Advertising, 169 W. Church St., Newark, OH 43055; faxed to (740) 345-9638; or e-mailed to curator@HeiseyMuseum.org. Whenever possible, please e-mail your ad. Always include your MasterCard or Visa number and expiration date. When mailed or faxed, ads should be typed or printed on white paper with dark ink. Camera ready ads are accepted, but must follow line specifications outlined at the beginning of the advertising section. Ads containing reproductions will not knowingly be accepted unless clearly stated (e.g. Heisey by Imperial, etc.). HEISEY NEWS accepts no further liability. In the event of a typographical error, the incorrect portion of the ad will be run in the following issue, but HEISEY NEWS assumes no further liability. See advertising section for rates and deadlines.

Museum

Heisey Collectors of America, Inc., a non-profit corporation (tax-exempt status), owns and operates The National Heisey Glass Museum in Veterans Park, 6th and Church Streets, Newark, Ohio. Open year round, Tuesday through Saturday 10:00 a.m. - 4:00 p.m., Sunday 1:00 - 4:00 p.m. (except Jan. and Feb.), closed holidays. Other hours by appointment. Members admitted free.

Identification

HCA will attempt to identify unknown glass items. Send a color photograph, measurements, and a self-addressed, stamped envelope to the attention of the Curator. Other arrangements should be made in advance with the Museum staff. Please keep in mind that the Museum cannot appraise items. Identification is free to members, non-members \$5.00 per item.

Membership

To join Heisey Collectors of America or to renew your membership, contact the HCA Administrative Office Monday through Friday 8:00 a.m. - 4:30 p.m. Eastern Time. Associate dues are \$30.00 plus \$5.00 for each additional household member. Voting members pay an additional one-time fee of \$25.00. Please consider supporting the Endowment Fund by joining at one of the levels listed on the back page.

Museum Gift Shop

There is always someone in the Gift Shop during the Museum's hours of operation to help answer questions or take orders. When ordering by phone, please have a credit card ready. When ordering by mail, please be sure to include appropriate charges such as shipping and sales tax. Please note that the HCA member discount does not apply to original Heisey or special project items.

Shipping and Receiving

Delivery is made much easier when we have a complete street address, not a PO Box. We prefer to use UPS. If you have not received a package, please call the Administrative Office to confirm it was sent. We will assist you in tracing it. If your package arrives damaged, please contact your local UPS representative. We insure everything.

Donations and Loans to the Museum

If you would like to make a donation to the Museum or have questions regarding items on loan, contact the Curator. HCA reserves the right to accept or refuse items based on current holdings.

HEISEY CALENDAR OF EVENTS

2009

HCA Benefit Auction	April 17-18
Select Auction List Submission Deadline	May 18
Convention Registration Deadline	June 4
Absentee Ballot Deadline to Have at Museum	June 18
Heisey National Convention and Elegant Glass Show Newark, OH	June 17-20
Percy and Vivian Moore Memorial Weekend	October 2-3
2009 Fifth Heisey Select Auction	October 3

Table of Contents

Utility Patents Associated with A.H. Heisey & Company (Part 2), Walter Ludwig	FC & 5-10
Heisey Calendar of Events	2
Message from the President, Bryan Baker	3
Curator's Report, Walter Ludwig	3-4
HCA Welcomes New Members for February 2009	4
339 Continental, Joe Lokay	10-15
36 th Annual 2009 All Heisey Benefit Auction, Dave Spahr	15-16
Benefit Auction Catalog Corrections	16
2009 Benefit Auction Preview, Walter Ludwig	16-17
Financial Management Update, Sharon Orienter	18
2008 End of Year Endowment Report, Sharon Orienter	18-19
2009 Fifth Annual Heisey Select Auction	19
2009 Select Auction Glass List	20
The Latest 2009 HCA Convention News! Co-chairs, Judy Rhoads and Mary Ann Spahr	21
2009 Convention Schedule of Events	22
HCA Convention 2009 Registration Form	23
Heisey Glass Museum Playing Cards, Order Form (Green Deck)	24
Club Notes	25
Advertising Guidelines	25
Real Heisey in the Gift Shop	25
Classified Ads	25-26
Dealer Directory	27
Museum Volunteers for February 2009	BC

MESSAGE FROM THE PRESIDENT

Bryan Baker

By the time you read this our Annual Benefit Auction will be just right around the corner - April 17 & 18. It is still not too late to make plans to attend this exciting fund-raiser for HCA. I just know there's something for everyone at this auction. Come on out and join us!

The weather has started to resemble something more like spring lately. I've been busy doing some outside chores around my home - does it ever end!? Our Museum is not immune from those yearly "to do's," I must admit. We've noticed a few shingles in the courtyard recently and have asked a local roofer to inspect our roof. Ohio has experienced some rather strong winds over the winter and, hopefully, it will just be a matter of replacing the few shingles that were blown off.

In addition to some minor roof repair, we will be working with a tree service to address one of the tree branches that is hanging precariously over the Museum addition. At that time, the City of Newark will also do some trimming of tree(s) that are beginning to have an impact on the Museum as well. This will be a coordinated effort - and more cost effective for both parties. We plan to have all this done before your arrival in June for Convention!

Can you believe Convention is just two months away?! The week's schedule and registration form can be found on pages 22 and 23. Now is the time to make your plans - don't forget to make your hotel reservations; you know how quickly they fill up! This is really shaping up to be a great week of activities thanks to some hard work and planning by our chairs, Mary Ann Spahr and Judy Rhoads - and, not to mention, an army of volunteers overseeing each event. Our theme this year is "Artistry in Glass: The Heisey Etchings". I don't know about you, but I'm itching to go - or should I say 'etching' to go!

I know I'm probably getting ahead of myself, but our annual Percy & Vivian Moore Memorial Weekend and Dinner is back in Newark, Ohio this year. The weekend will coincide with our Select Auction that will be held on October 3. We haven't hammered out all the details just yet - we still have a Convention to put on! But rest assured, the weekend will be another one for the memory books. There is talk of holding an immense flea market on the Museum grounds the morning before the auction. Again, I don't want to get too far ahead; but keep that weekend 'etched' on our calendar.

We have received word of the recent passing of club member Dr. John G. Griffith III of Connecticut. Our thoughts are with his wife, Alyce, and his family at this time.

See you at the Benefit Auction!

Until next time,

Bryan Baker ♦

CURATOR'S REPORT

Walter Ludwig

We are emerging from our winter doldrums here in Ohio. There is promise everywhere of the coming of spring. There are buds on the trees and birds chirping in the yard. I have seen some crocus blooming now and tulips and irises are beginning to poke out of the ground. The fish in my backyard pond have come out of their winter hibernation and are now looking to be fed again. This is the good time of year when everything is full of hope and promise.

One of the looked forward events of spring is the Heisey Benefit Auction that we will be holding here in Newark on April 17 and 18. Dave Spahr, auction chairman, has done a great job of pulling it all together. He has details of the auction in an article on page 15. This is followed by a few corrections to the auction catalog and then an auction preview that I have

put together. My preview could have easily gone on for another two pages because there are so many great items in this auction. Do come and join us if you can, it will be a great time.

Our Convention co-chairs, Mary Ann Spahr and Judy Rhodes, have another article in this Newsletter further expanding on the activities you have in store for you when you come to Convention this year. You will also find the Convention Schedule of Events on page 22 and the Convention registration form on page 23. They really have some new and exciting things planned. I hope you are able to be here. Do get your reservations in as soon as possible.

Convention Seminars

Mary Ann and Judy asked that I write a bit to let you know more about the two seminars that I will be presenting during Convention. The first seminar on Thursday, June 18, at 3:00 p.m. at Adena Hall (where the glass show is held) will be an overview of the actual etching process. I will have examples of all of the different styles of etchings that Heisey did. There also will be examples of the etching plates with which Heisey used to produce these wonderful delicate pieces. A station will be set up so that you can do a rubbing from an original Heisey etching plate. Because these are so heavy, we will only have a couple of examples for you to use for this purpose.

The second seminar which will be held on Friday, June 19, at the same time and place as the first seminar. This seminar will be an overview of all of the different etchings that Heisey produced. An emphasis will be put on stylistic changes in etchings and how the machinery affected these changes. We will look at different themes in etchings and why the company thought they would be successful. Special attention will be given to custom work that the company did for individual clients. I hope that many of you will be able to attend these seminars and learn more about the story behind Heisey etchings.

Our dining room table display has changed with the season and now has a beautiful display of Heisey 1184 Yeoman pattern brought in by Phyllis McClain. Phyllis has a wonderful knack of adding just the right accessories to the table to make it a real show piece. Do stop in at the Museum to see this great spring themed table.

Work here continues to go along at the Museum. Thankfully we are beginning to see more visitors. We have had several small tours come through the Museum with even more scheduled. Nothing makes us happier than when we can share our great Museum with others who have not heard the story of Heisey glassware.

After Convention is over it will be time to clean the glass in the Museum again. The last time this was done was the beginning of 2007 when we reorganized the whole Museum. If you would like to volunteer to help me in this task, please contact me during Convention and I will add you to the list to be called when it is time to tackle this job.

The yard sale and outdoor flea market season is about to start. Take a look at your local newspaper and see what is out there. I am sure that at one of these places in your area there is a treasure to be found. It is not going to find you; you need to get out there and find it. Enjoy your Heisey hunt. ♦

HCA WELCOMES NEW MEMBERS FOR February 2009

Larry Barnhouse &
Fred Hankinson, PA
Irbi Nelson, WY

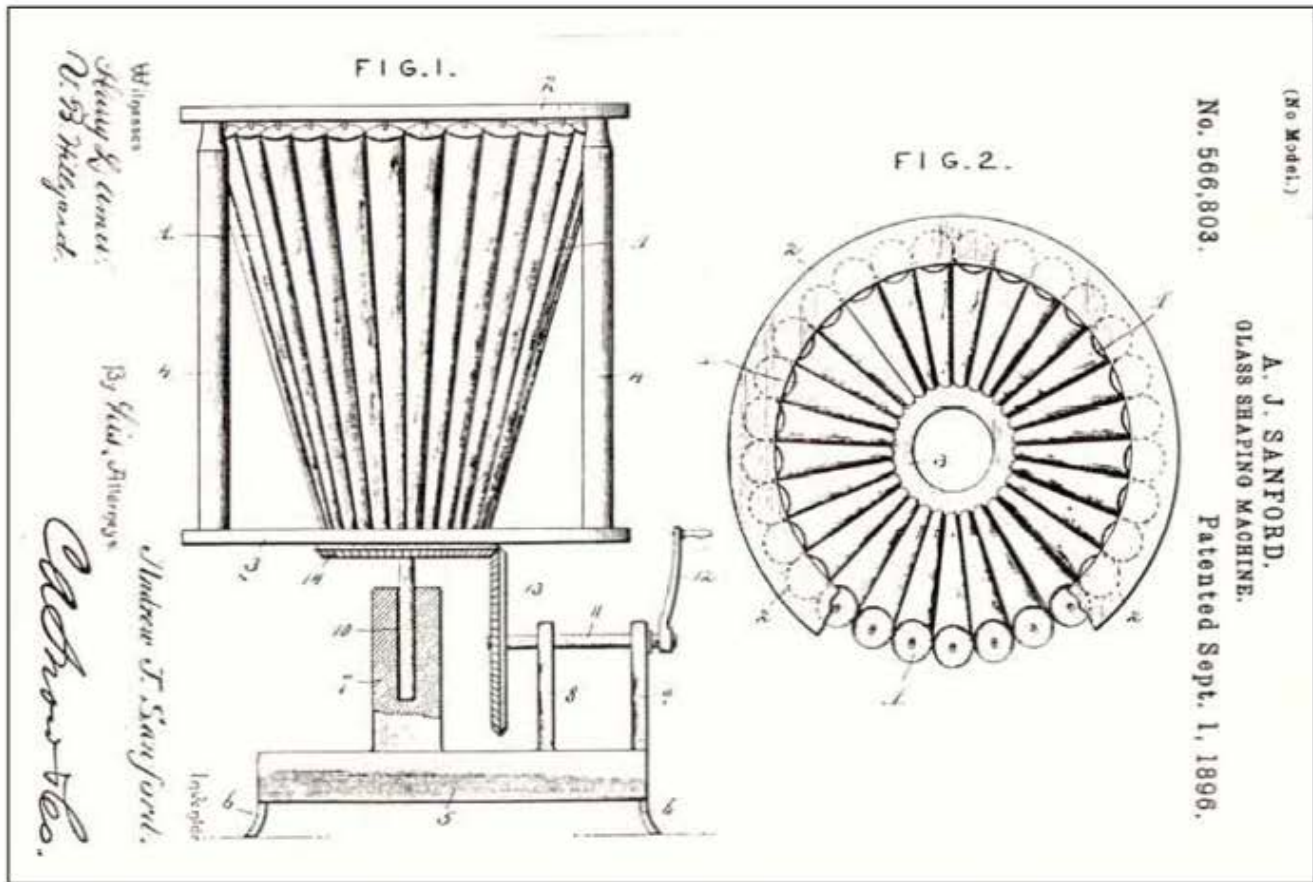

Patent 566,803

UTILITY PATENTS ASSOCIATED WITH A.H. HEISEY & COMPANY (PART 2) Walter Ludwig

Last month, we started our look at the utility patents that were assigned either to the Heisey Company or an individual associated with the company. In that article we only had space to look at those patents that had been granted to A. H. Heisey before he founded A. H. Heisey & Company in Newark, Ohio, in 1896. This month we will look at patents granted from 1896 until 1905. All of these patents deal with the process of finishing glass after it has been molded. Obviously, this was a labor intensive process that was in need of improving both to cut costs and to produce a better finished product.

The first one we will look at is Patent 566,803 which was granted to Andrew J. Sanford of Zanesville, Ohio, on September 1, 1896. I am in a bit of a dilemma as to whether this patent should be included or not. There is no disputing that Andrew J. Sanford was one of the key employees that A. H. Heisey hired early on to start the factory here in Newark. Sanford became head of the mold shop at the factory and was constantly on call to fix anything that might go wrong at the factory. It is entirely possible that Andrew J. Sanford was employed by Heisey to supervise the construction of the glass factory here at Newark. This patent was applied for on April 17, 1895, so it is also possible that it predates Sanford's employment by Heisey. But since it is for a "glass-shaping" machine I am including it in this article to show that Sanford was quite familiar with the workings of a glass factory.

The piece of equipment is actually used to finish a blown or molded piece of hot glass to give it

finishing properties to contour to the shape of the cylindrical shaped hopper. This process can add flutes to the piece, as well as, giving it its overall finished appearance.

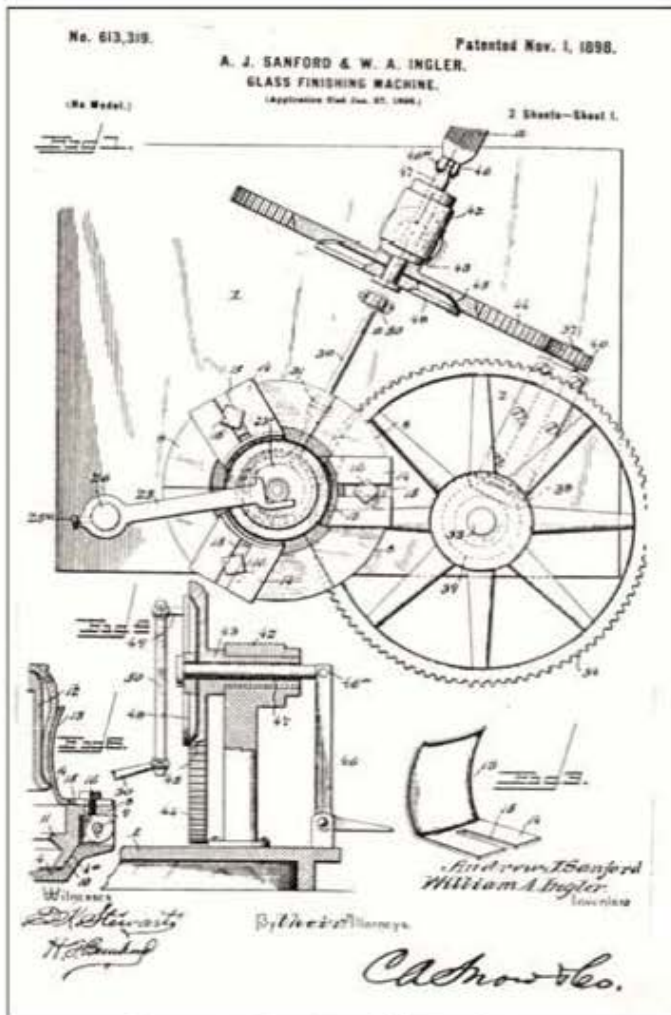

Patent 613,319 – Illustration 1

Our next utility patent was granted on November 1, 1898, to A. J. Sanford of Newark, Ohio, and William A. Ingler of Zanesville, Ohio. This patent was applied for on January 27, 1898, and granted as Patent No. 613,319 on November 1, 1898. As you notice Andrew Sanford is now a resident of Newark and is definitely in the employ of A. H. Heisey & Company at this time. This patent covers a glass-finishing machine for which the description in the patent runs to five pages.

Once again we have a machine that will improve the way that a glass article is handled in the finishing process of making it into a useful

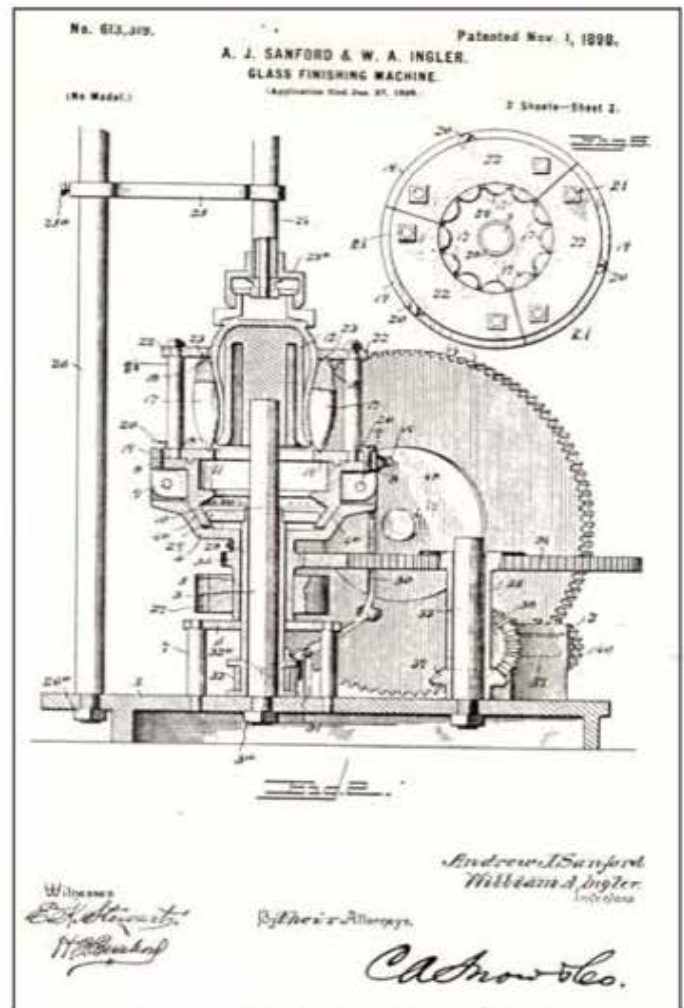

Patent 613, 319 – Illustration 2

piece of glass. “Our invention is an improvement in machines for finishing glass articles by the abrasive action of a buffer on the surface of the article; and the object that we have in view is to provide a simple mechanism by which differently-shaped articles may be finished rapidly and economically.

“A further object that we have in view is to provide an improved mechanism by which the buffer or the buffer-roll may be brought by gentle motion into contact with the work, thus obviating marring of the surface of the work, and at the same time we obtain a positive motion to the driving mechanism.”

The illustrations certainly make this look like a formidable machine.

The third invention in this series was granted Patent No. 663,023 on December 4, 1900 in the

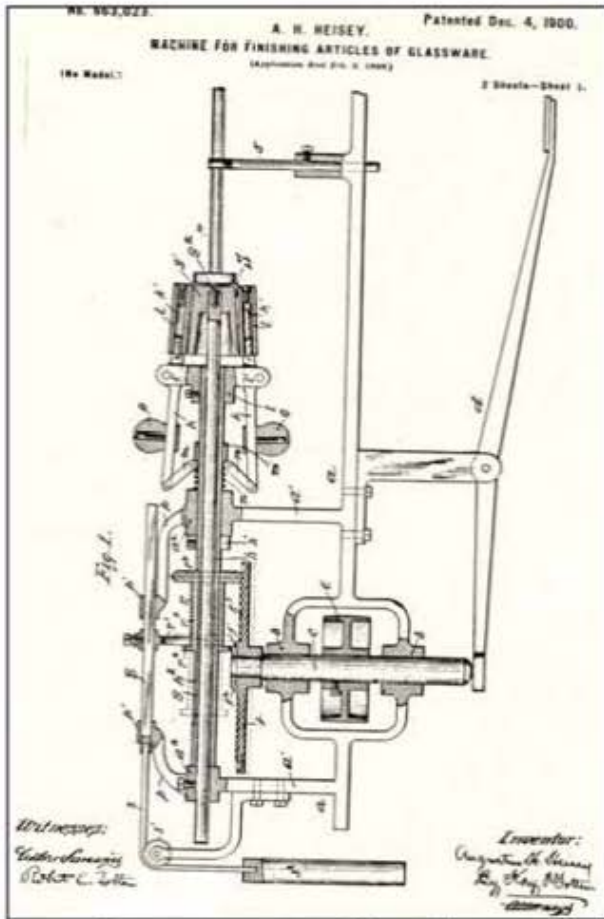

Patent 663,023 – Illustration 1

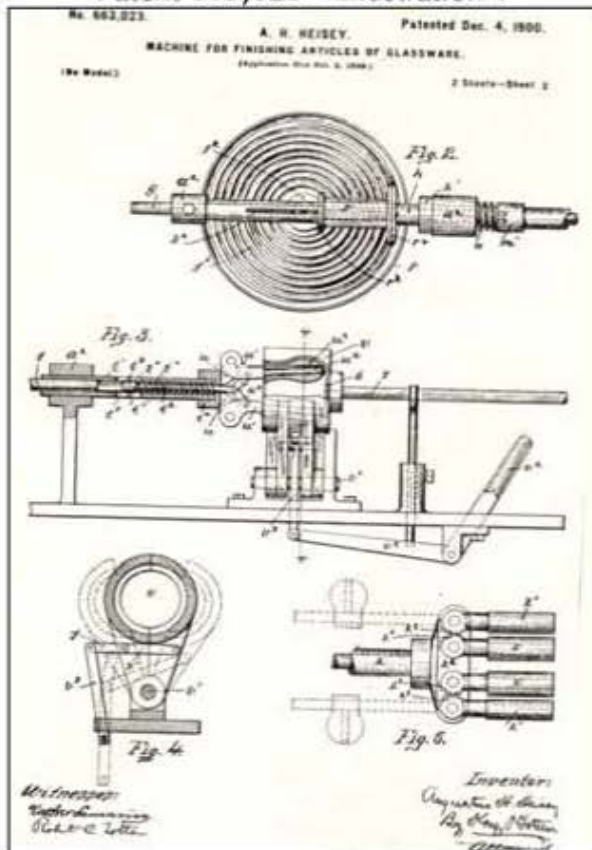

Patent 663,023 – Illustration 2

name of A. H. Heisey of Idlewood, Pennsylvania. (You will notice that A.H. Heisey's official residence was still in Pennsylvania at this time and not in Ohio.) The application for this patent was filed on February 4, 1898.

This was another glass finishing machine. "The object of my invention is to provide a machine in which the finishing-tools which revolve around the article are gradually brought into contact with the article, their pressure against the article being governed by centrifugal force."

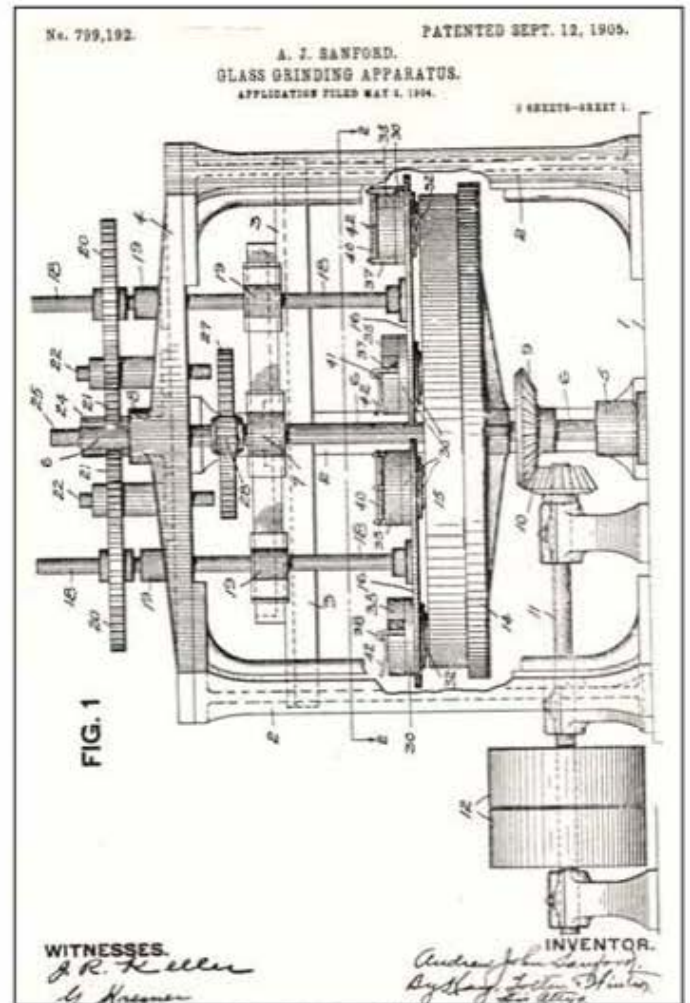

Patent 799,192 – Illustration 1

The final two inventions in this series will be considered together. They are for "a glass grinding apparatus" and are covered in Patent numbers 799,192 and 799,193. Both patents were applied for on May 2, 1904 and granted on September 12, 1905. In both cases the inventor is listed as Andrew John Sanford of

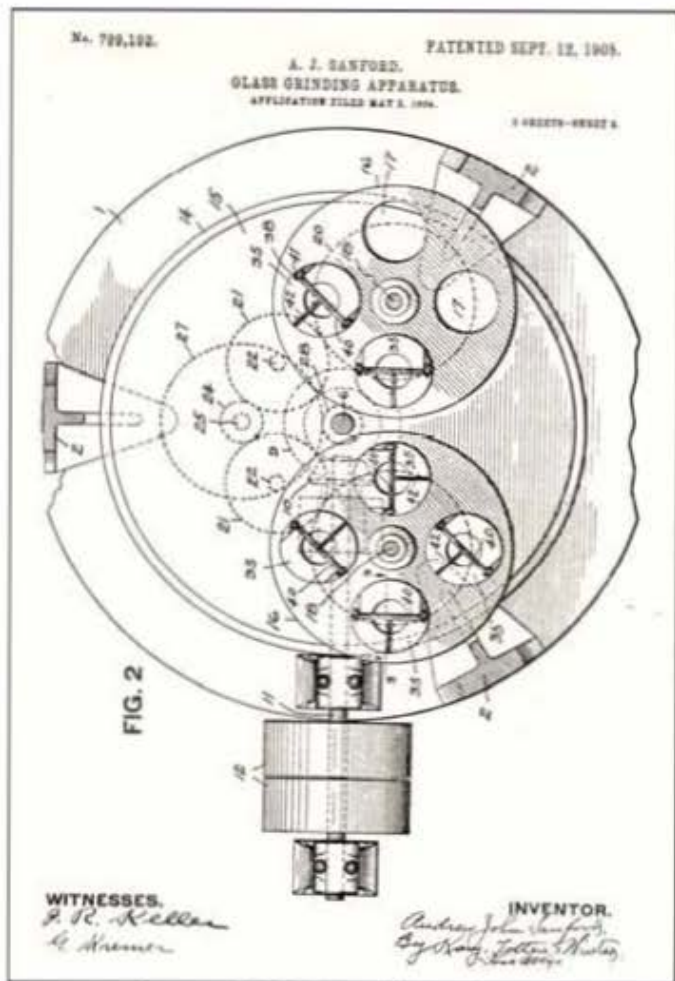

Patent 799,192 – Illustration 2

Newark, Ohio, with the assignor listed as A.H. Heisey & Company of Newark, Ohio. This means that Andrew John Sanford is acknowledged as inventor of the product, but that the actual owner of the patent is A. H. Heisey and Company.

Both of these patents are for a holder to be used in conjunction with ordinary glass-grinding machines in order to finish off an article of glass. The difference between the two patents is what the particular article to be finished was. In the case of 799,192 the article was nappies or bowls, while for 799,193 a more general term of "flat ware" was used.

The reading of 799,192 is "The object of my invention is to provide a holder for the article to be ground and which may be used with ordinary types of glass-grinding machines, such as tumbler-machines, and which is adapted

especially for holding nappies, bowls, and similar flaring glass articles."

Patent 799,193 reads, "The object of my invention is to provide means whereby ordinary types of glass-grinding machines, such as tumbler machines, may be used for grinding the glassware commonly known as 'flat ware.'"

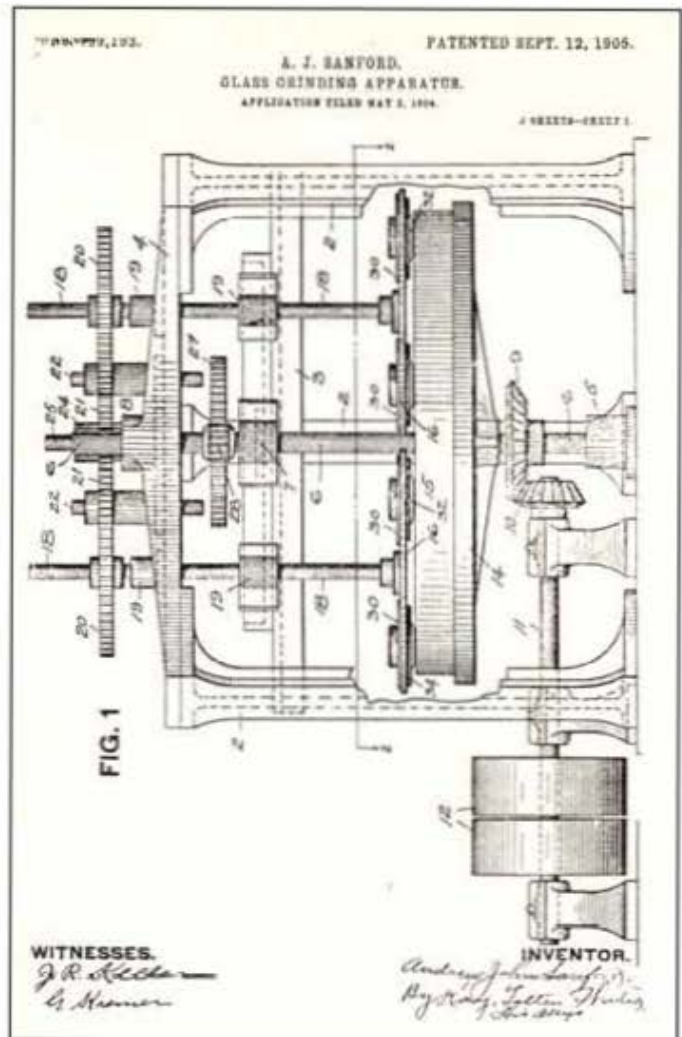

Patent – 799, 193 – Illustration 1

Both patents then continue with the same words, "In the manufacture of pressed glassware the pressing and reheating process leaves on the bottom of the article more or less pronounced fins, ribs, and other projections, which must be removed by grinding. In the case of tumblers and a few other practically cylindrical articles this grinding has been accomplished by means of machinery. The type of machine in most general use for this purpose comprises a horizontally-arranged stone rotated at a high

speed and a disk or disks located above the stone and slowly rotated in a direction opposite the rotation of the stone, which disk or disks are provided with openings therethrough, into which the tumblers or similar articles are set with their bottoms resting upon the rapidly-rotating stone. The disks hold the tumblers from being carried around by the stone and also carry them slowly in the opposite direction, the combined effect of the stone and disks imparting rotation to the tumblers.

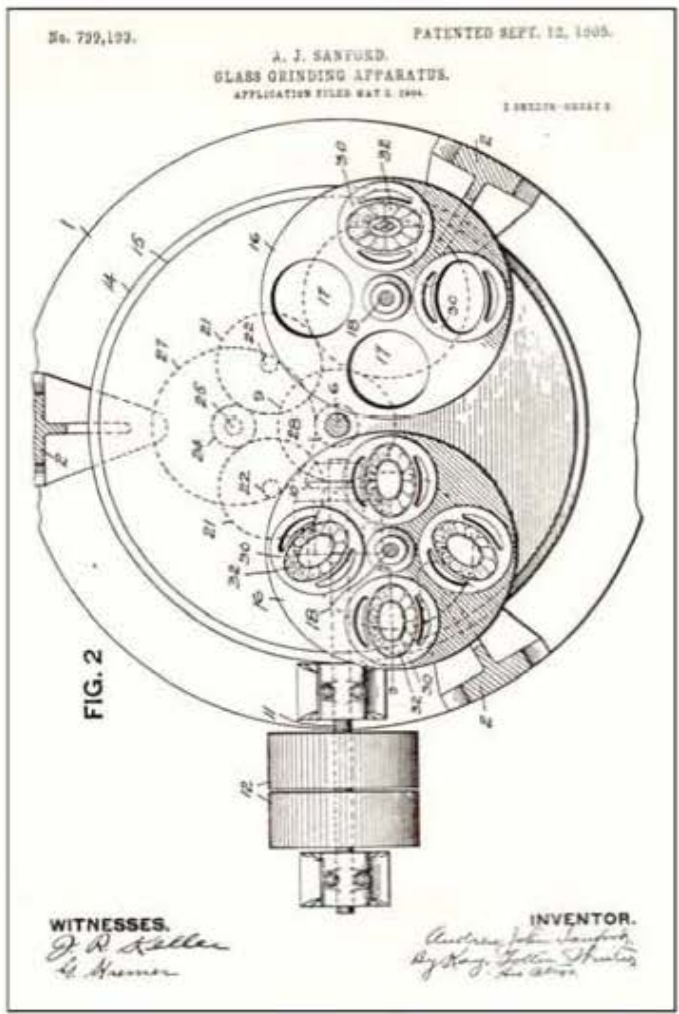

Patent 799, 193 – Illustration 2

At this point the two patents diverge.

Patent 799,192 (for bowls and nappies) continues, "To produce the necessary friction between the tumblers and the stone to produce a grinding effect, the custom is to place a bag of shot or other suitable weight into the tumbler. While such machines have been in quite general use for grinding tumblers and a few other

practically cylindrical articles, they have been found unadapted for grinding nappies, bowls, and other glass articles having a flaring shape. This is due to the fact that the thin disks bear against the rounded or flaring surfaces of the nappies and cause such articles to be lifted from the stone and rolled or tumbles in the opening in the disk, thus quickly ruining such articles. As a consequence nappies, bowls, and the like have heretofore had their bottoms ground by holding them by hand against the side of a vertically-rotating stone. This work is quite tedious and slow, and the labor incident thereto adds considerably to the cost.

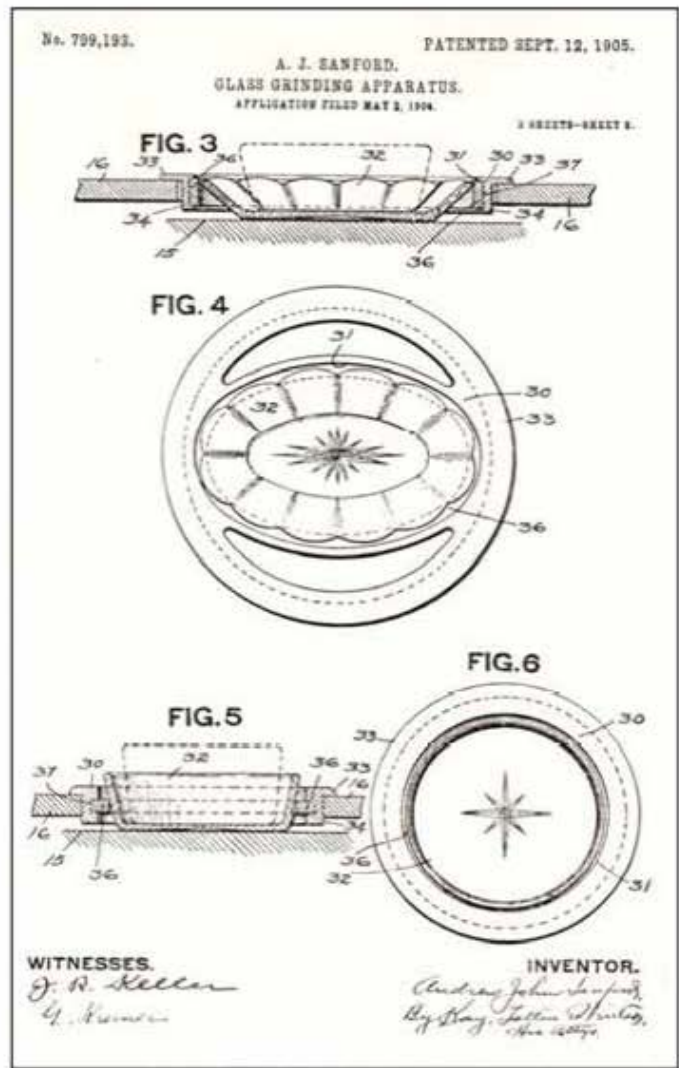

Patent 799,193 – Illustration 3

"The object of my invention is to provide a suitable holder for nappies, bowls, and similar articles in which such articles can be clamped and which can be placed in the opening in the

disk or disks of ordinary tumbler-grinding machines and which will hold the articles in true vertical position with their bottoms bearing against the stone and preferably being of sufficient weight to supply the necessary adhesion between the article and the stone."

Patten 799,193 (for flat ware) continues similarly, "While such machines have been in quite general use for grinding tumblers and a few other practically cylindrical articles, they have been found unadapted for grinding flat ware, such as plates and other low flat dished. This is due to the fact that the disks of such machines are comparatively thin, so that only a shallow bearing is presented, against which the edges of the article must rest. As the latter are low and flat, they are liable to slip underneath the disk between the same and the grinding-stone, and this results in either breaking the article or at least grinding it so irregularly that it has to be discarded. This liability is increased by the fact that the top surface of the stone is seldom, if ever, true, as it generally wears away irregularly, and as a consequence the article rises and falls slightly during the grinding process, and the thin disks have not a bearing surface of sufficient height to permit or any appreciable rise and fall of the article. For these reasons grinding-machines of the character described have never been adapted for grinding flat ware, and such ware has heretofore been ground only by holding it by hand against the sided of vertically-rotating stones. This work is quite tedious and slow, and the labor incident thereto adds considerably to the cost.

"The object of my invention is to provide an improved holder to cooperate with the disk of a grinding-machine of the character described and which is to be used in the grinding of flat articles to prevent the difficulties just referred to."

The drawings for the two different patents are of the same different parts of the machine and differ only slightly. The first illustration is of the machine as a whole. The second looks at the apparatus for holding the item to be ground in relation to the grinding surface. The third

illustration (and those that follow) shows the article being ground in the specially built holder for the object. I have used this third page of illustrations for patent 799,192 as the cover of this issue of the Newsletter. You can clearly see a colonial Heisey bowl as it is held in the holder. The third illustration for 799,193 shows a colonial oval celery dish in a similar holder.

Next month we will continue to look at the utility patents associated with A. H. Heisey & Company. One of them will be for an interesting piece of glass that Heisey added a metal piece to in order to create something very different. ♦

339 CONTINENTAL

Joe Lokay

The 339 Continental pattern was introduced in late 1902. A total of 67 items were offered in Heisey Price List #100, circa 1903. Most items were still offered in Price List #142, circa 1908. There were only 10 items left in Price List #155, circa 1910. In Heisey Catalog #75, circa 1913, all 339 Continental items were gone except the tumblers, water bottle (with the pattern changed to 400 Colonial Scalloped Top), sherbet, egg cup and oyster cocktail. The water bottle continued to the 1940s, and the other four items ended in the late 1910s. The life of the pattern is set at 1902-1911 or about 10 years. Heisey named the pattern Continental.

The pattern was made in crystal only except for the water bottle which has been found in Flamingo. This places the water bottle in the late 1920s. Most 339 items were offered with a #64 gold decoration. The gold was placed around the top edge, and a gold band was placed around the body just above the swell. Some 339 items have been found with the #65 engraving. Outside firms may have added ruby decorations to items in 339.

Continental is a colonial design with long, wide panels with scallops at the top where feasible. The vertical panels increase in diameter as you

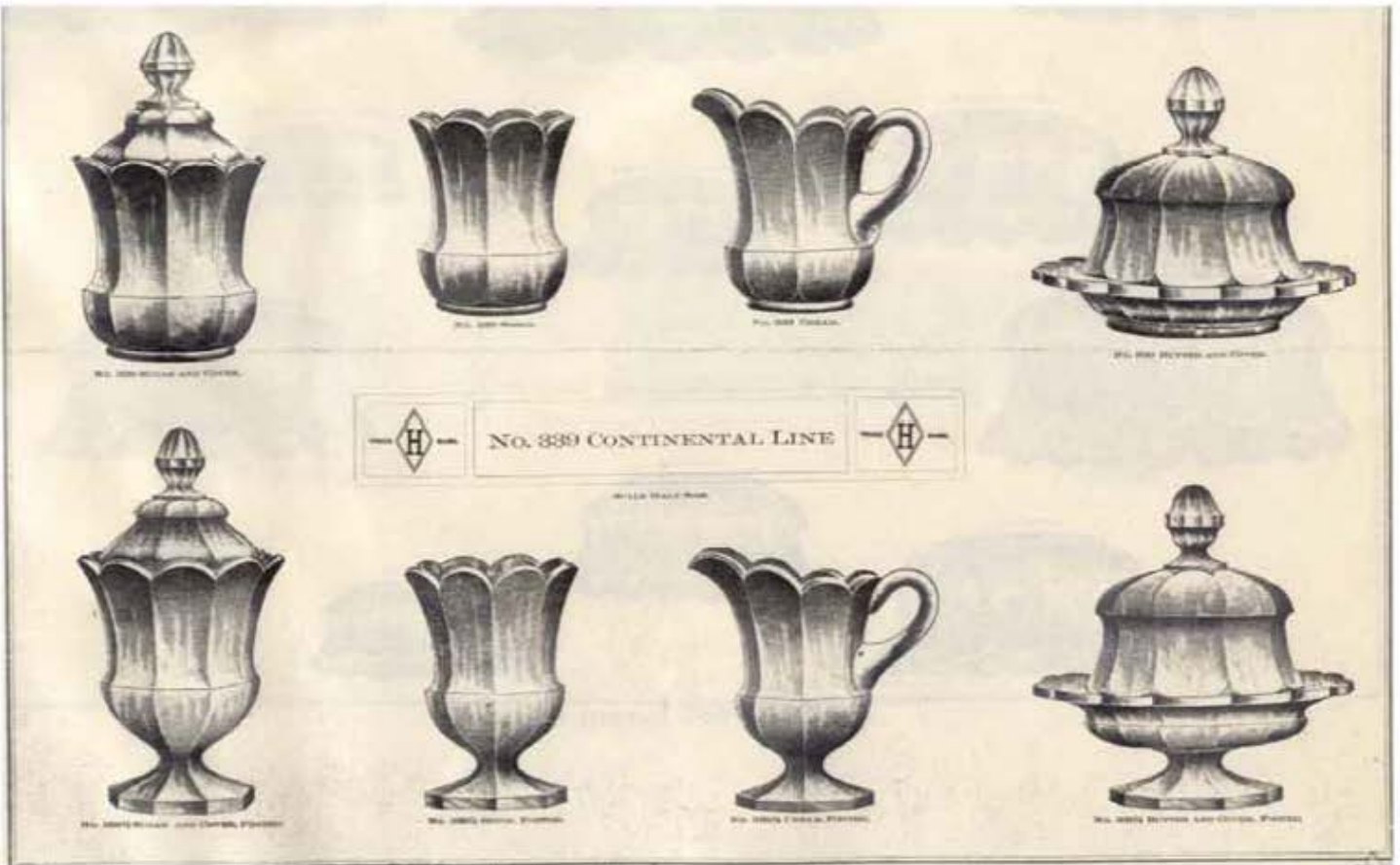

Catalog 50 – Page 51 (Vogel I – Page 51)

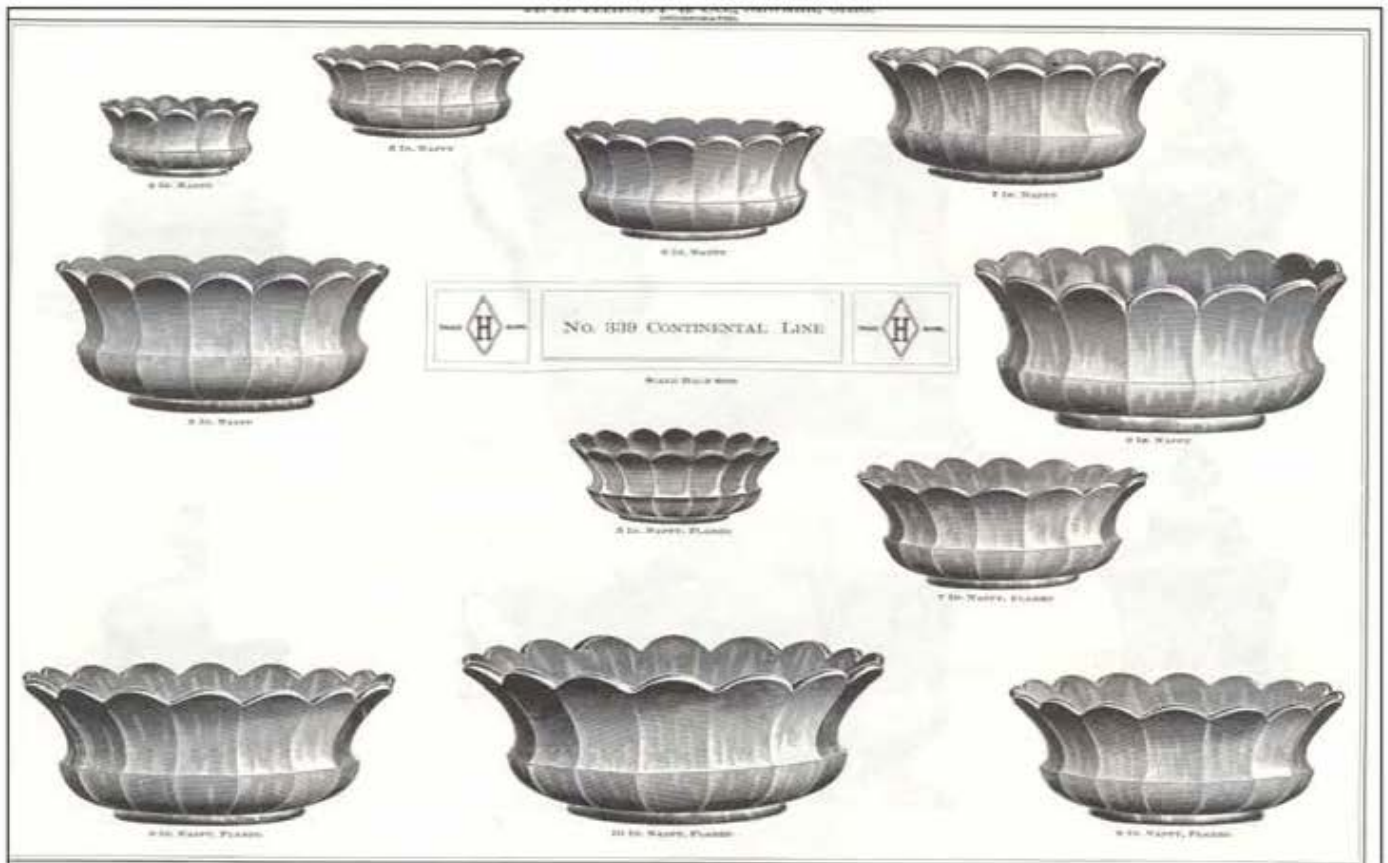

Catalog 50 – Page 52 (Vogel I – Page 52)

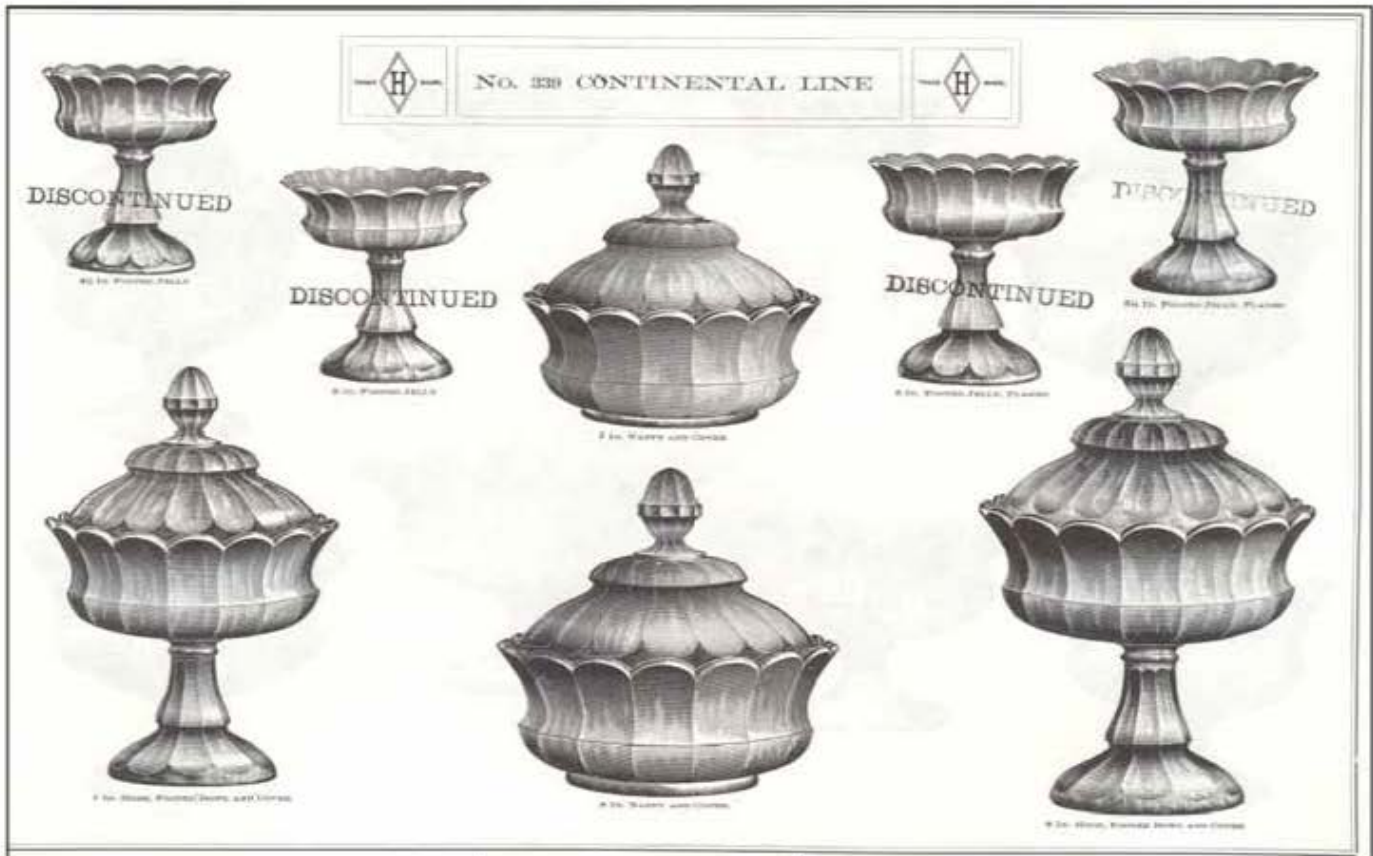

Catalog 50 – Page 53 (Vogel I – Page 53)



Catalog 50 - Page 54 (Vogel I – Page 54)



Catalog 50 – Page 55 (Vogel I – Page 55)



Catalog 50 – Page 56 (Vogel I – Page 56)



Catalog 50 – Page 57 (Vogel I – Page 57)

go up from the bottom, and then make an abrupt turn inward gradually decreasing in diameter for a while. This is what is called the swell. On the butter lid the swell is reversed. All items are signed with the Diamond H except the mold blown items such as the water bottle or cruet. The Heisey star is in the bottom of applicable items.

There are two table sets in the pattern. One is normal, and one is footed. The footed set is given number 339 ½. The fifth and last item with the 339 ½ number is a 10 in celery tray. Within the 67 items, there are 32 different sizes of nappies and bowls, covered or uncovered; a goblet and wine, 2 sizes of tumblers, 2 styles of salt and pepper, 2 cake servers, 3 sizes of pitchers, an oil bottle (cruet), a toothpick and a punch cup. There is no punch bowl.

The catalog pages for the pattern note that a patent had been applied for on the pattern. However, we can find no record that a patent was ever granted for the 339 Continental pattern. This may mean that the patent office

did not find that the pattern was sufficiently different from other colonial patterns (either produced by Heisey or other companies) for the claim that it was a new innovation in pattern to be upheld.

Production of #339 Continental

1. spoon
2. cream
3. sugar and cover
4. butter and cover
5. nappy, 4"
6. nappy, 4 ½"
7. nappy, 6"
8. nappy, 7"
9. nappy, 8"
10. nappy, 9"
11. nappy, flared, 4 ½"
12. nappy, flared, 5"
13. nappy, flared, 7"
14. nappy, flared, 8"
15. nappy, flared, 9"
16. nappy, flared, 10"
17. nappy and cover, 7"

18. nappy and cover, 8"
19. oblong, 7"
20. pickle tray, 6"
21. spoon tray, 6"
22. bon bon, No. 1, 6"
23. bon bon, No. 2, 6"
24. bon bon, No. 3, 6"
25. jelly, handled, 5"
26. jelly, 3 cornered, handled, 5"
27. jelly, footed, 4 ½"
28. jelly, footed, 5"
29. jelly, flared, footed, 5"
30. jelly, flared, footed, 6"
31. bowl, low footed, 7"
32. bowl, low footed, 8"
33. bowl, low footed, flared, 8"
34. bowl, low footed, flared, 9"
35. bowl, low footed, 7" & cover
36. bowl, low footed, 8" & cover
37. bowl, high footed, 7"
38. bowl, high footed, 8"
39. bowl, high footed, 9"
40. bowl, high footed, flared, 8"
41. bowl, high footed, flared, 9"
42. bowl, high footed, flared, 10"
43. bowl, high footed, 7" & cover
44. bowl, high footed, 8" & cover
45. salver, 9"
46. salver, 10"
47. celery, tall
48. jug, 3 pint
49. jug, half gallon
50. jug, 3 quart
51. goblet, 9 oz.
52. wine
53. egg glass or cup, footed, 5 oz.
54. sherbert, footed, 4 ½ oz.
55. oyster cocktail, footed, 5 oz.
56. tumbler, 8 oz.
57. tumbler, 9 oz.
58. custard, 4 oz.
59. toothpick
60. salt or pepper, No. 2, P.T.
61. salt or pepper, No. 3, N.T.
62. oil, 6 oz., pressed or cut stopper,
63. molasses can, 13 oz., O.K. top or N. top
64. water bottle
65. finger bowl
66. sugar, hotel

67. cream, hotel

Production of #339 ½ Continental

1. spoon, footed
2. cream, footed
3. sugar, footed and cover
4. butter, footed and cover
5. celery tray, 10"

References

1. Heisey Price List #100 (1903)
2. Heisey Catalog #50 (1905)
3. Heisey Price List #120 (1906)
4. Heisey Price List # 142 (1908)
5. Heisey Catalog #56 (1909)
6. Heisey Price List #155 (1910)
7. Heisey News, Jan. 1974, Pattern #339 & 339 ½
8. Heisey News, May 1976, #339 Tumbler
9. Heisey News, Jan. 1982, Little Things
10. Heisey News, March 1983, Little Things
11. Heisey News, July 1986, Chronology 1904-1909
12. Heisey News, Feb. 1990, Pattern #339
13. Heisey News, April 1990, #339 6 oz. Cruet
14. Heisey News, Aug. 2000, #339 Bowls
15. Heisey News, April 2003, #339 Punch Bowl
16. Vogel Book 1, p 51-57 ♦

36th ANNUAL 2009 ALL HEISEY BENEFIT AUCTION

Dave Spahr

Our 36th Annual Benefit Auction will be held **April 17 & 18, 2009** at last years location, the GMP Local #244 Union Hall at 244 Hudson Ave. in Newark, Ohio.

We have received 936 lots of some wonderful glass for the benefit auction, and as Walter said, some exceptional pieces which one rarely sees for sale. Our curator, Walter Ludwig, has given you a glimpse in an article elsewhere in this Newsletter.

The auction catalog, preview hours, auction hours, absentee bid instructions, absentee bid form, bidding information, and most importantly the list of sale items are on our website - www.HeiseyMuseum.org . You have time to look and evaluate items and prepare for this great auction! Also listed are names and addresses of area hotels/motels to assist you in making reservations. You will want to arrive in time to attend the two-hour preview on Friday April 17, 2009, 2:00 p.m. to 4:00 p.m. with the auction beginning at 4:00 p.m. On Saturday April 18, 2009, the doors will open at 8:30 a.m., the annual membership meeting will be held at 9:00 a.m. with the auction beginning at 9:30 a.m.

As we have done for the last two years, we have decided not to have a full mailing of the auction catalog this year. The time has past for you to call the Museum and have a copy mailed to you. We will have copies available at the auction for a minimal fee of \$3.

As you know, the Benefit Auction is HCA's largest fund-raiser and 2009 will be another challenging year financially for the organization. This auction is slightly larger than last year's auction and we have an abundance of nice damage free glass this year. If you can't make it to Newark for the auction this year, I encourage you to put in an absentee bid. Again, forms and instructions are available on our website. This is a way for every member to support your association!!

Finally, a special note for absentee bidders: We are having absentee bidders make their own arrangements to have their glass shipped and included in the absentee bid instructions the area shippers and their telephone numbers who will pick up, package, and send your glass to you. The absentee glass will be available for pickup at the Museum on Tuesday, April 21, 2009. Absentee bidders will have to pay their shippers directly. We will cooperate with your shipper and assist where we can. HCA simply does not have the volunteers, materials on hand, and staffing capability to do this task.

As you read this newsletter I will be looking for help at the auction - for "Vannas" to hold up the glass, for folks to help move glass during the auction, and clean up after the auction. If you would like to help, please contact me or see me at the auction. It is a great way to learn about the glass and meet some great volunteers.

If you have questions or concerns, please contact me at masdgs@aol.com or give me a call at 937-372-7166. I'll see you at the auction!



BENEFIT AUCTION CATALOG CORRECTIONS

Lot 409 1401 EMPRESS D F CANDY BOX NO LID
COBALT

Lot 454 142 CASCADE 3-LT CANDLESTICK
W/507 ORCHID ETCH

Lot 536 1485 SATURN CRUET NO STOPPER

Lot 921 1951 CABOCHON CANDY-LID ONLY
W/515 HEISEY ROSE ETCH (word jar deleted)

2009 BENEFIT AUCTION PREVIEW

Walter Ludwig

WOW! Have you taken a look at the Auction Catalog? It was mailed to everyone who asked for it, but it is also available on-line at the Museum web site (www.HeiseyMuseum.org). Do take a look at it because there is glass there for every collector. There are the show stoppers that make any collection unique, there are the more common pieces that can fill out a set or get a collection started. My space in this article is limited, but I will try to point out some of the more unusual pieces that are available for you to bid on at the auction that will be held April 17-18 here in Newark.

The auction starts off with a big one, a beautiful 1235 Beaded Panel and Sunburst punch bowl and base (1). This is quickly followed with a 1550 Fish bowl (4) and a bit later with a 14 Kingfisher floral block in Hawthorne (19). All

this and we have not even gone through 20 lots in the auction.

This is the auction if you like animals and animal related items because there are so many that you seldom see. There is a 1 Airedale (262) as well as a 1 Filly Head Forward (255). There are in Honey Amber a 1522 Standing Colt (416) and a 1540 Plug Horse - Oscar (417). Other animals include wood ducklings both 21 floating and 22 standing in lot 265 and a Flamingo 14 Kingfisher flower block (144). There is the smaller of the two 5058 Penguin decanters (235) as well as a large group of rarely found figural stems: 5058 Goose Stem sherry (429), 5058 Goose Stem cocktail (245), 5066 Horsehead cocktail (241), 5065 Colt Stem cocktail (242), and 5063 Bantam Rooster cocktail (243). A real beauty is the 4045 9" ball vase with 825 Sea Glade cutting (123) – the fish swimming around the bowl make this a gorgeous presentation of this rarely seen Heisey decoration.

The other category that the auction has a great number of lots in is 515 Heisey Rose. There is complete serving for four in all of the stems and plates as well as a large number of accessory and serving pieces. Unusual pieces include the 4164 Gallagher jug (55), a 1519 Waverly covered lemon with original store sticker (919), and two 5012 Urn bud vases in different sizes, 8" (909) and 6" (910).

This is a good auction for toothpick collectors with many unusual ones coming on the block. There is a 1776 Kalonyal (316), a 341 Puritan footed (308), a 325 Pillows (424), and a 1200 Cut Block with Ruby staining and "Pan American Expo" souvenir (312) among the more than twenty being offered.

Did you want to hear about some of the true rarities in this auction? Well, there is nothing rarer than the two 300 Old Williamsburg 18" candle lamps (142 & 143) that showed up this year. What makes them so special? I am glad you asked, they have 507 Orchid etching on them – and it is not just the globes that have the

etch, but the bases on these are also etched. We have no record of Orchid ever appearing on any hurricane globe and there is no record of an etching ever appearing on the base of a hurricane either. Together these make a truly unique presentation of Heisey's most popular etching. Do check the catalog because there are some condition issues with these rare pieces – but I doubt if you will ever have another chance to add a piece like this to your collection.

Other rarities include a pair of 4182 Thin 6" plates with 507 Orchid etch (286), a pair of 141 Edna candlesticks (406), a 352 Flat Panel knife rest (485), a 1503 Crystolite pressed goblet (620), a 150 Banded Flute root beer mug (978), and the 1 Tea Drip with sterling rim (981).

Rarities in color include a 134 trident 2 light candlestick with Sahara top and Alexandrite base (403), a 1404 Old Sandwich 16 ounce cream in Cobalt (405), and a 3386 Diamond Rose pilsner in Sahara (499). In Vaseline there is a 1192 Inside Scallop shallow 8" nappy (404) as well as a 1184 Yeoman 9" plate (735). Lot 627 is a rare 337 Touraine sherbet in Amberina.

Among the early patterns there are several lots of 1280 Winged Scroll in Custard including a table set (28), tankard and three tumblers (25), and a 13" tray (422). In the same pattern in Emerald there is a 4" pin tray (421). Another outstanding early piece is a 1200 Cut Block tall celery (407).

There are two lots in the auction with Krall bird cuttings. Lot 503 is a 4163 Whaley beer mug and lot 525 is a 4054 Coronation cocktail shaker. I should also mention that there are a group of 10 lots (676 – 685) of 1401 Empress Moongleam that could be the start of a really nice collection.

Space prevents me from listing all of the great items in this auction. I will add that there are three lots of tools that came from the Heisey factory (350, 950A, and 950B). Please do come (or send in an absentee bid) because this is one you do not want to miss. ♦

Financial Management Update

By Sharon Orienter, Treasurer

There has not been a Treasurer's report since November because we are in a transition period with our financial management and reporting. We have not had a Business Manager since early December and your Executive Committee has been working with our remaining staff and our accountants to make sure the tasks that are necessary to the every-day running of our organization get done.

We have updated access to all of our accounts; located and properly stored important documents, keys, and cards; and are in the process of streamlining our financial reporting systems.

I want to thank Vice President, Charlie Wade for all he has done to make sure bills get paid and various other things get taken care of. I want to thank Walter Ludwig for picking up additional duties and making sure deposits and payroll get done in a timely manner. I also want to thank the other members of the Endowment Committee (Linda Bishoff, Robert Loch, Dick Smith) and Budget Committee (Tom Files) for their patience and input during this difficult time. Their analysis and advice have been appreciated.

Wells & Priest, our accountants, have recently provided a draft financial report, which was reviewed and approved at our last Executive Committee meeting. As soon as a few corrections are made to that, we will be back to regular financial reporting and I'm hoping to have the first quarter 2009 report for you soon. We are still working on the 2008 year-end report, I ask just a bit more patience and will be happy to try to answer any specific questions.

I never expected to be quite as involved in the hands-on financial management of HCA as I've been these past few months and it's been quite an eye-opener. Fortunately our 2008 Endowment income is \$78,000 and I have

authorized the first drawdown of those funds to operating accounts. It is vital that all of our fund-raisers be as effective as possible this year.

There is some beautiful glass in the Benefit Auction and I hope everyone will come and buy! The Convention Chairs (Mary Ann Spahr and Judy Rhoads) have great plans for us in June and I hope everyone will attend and make that a success as well. ♦

2008 END OF YEAR ENDOWMENT REPORT

Sharon Orienter, Treasurer

With the 4th Quarter 2008 Endowment report from Park National Bank, I received the following notes from our fund manger, John Uible

"The time-weighted total return was -16.77% for 2008 as compared with the benchmark return of -18.61

"For the calendar year, the Dow Jones Industrial Average (DJIA) produced a return of -32% for its worst performance since 1931. The Standard & Poor's Index (S&P 500) posted a return of negative 36.5%, its worst performance since 1937, while the NASDAQ Composite Index came in at negative 40.5%, the worst performance in its 38-year history."

Though we have lost principal in our endowment, we have lost less than many investors, thanks to Park's prudent management. Our own decision to increase percentage from growth to income has helped us retain our principal. And, keep in mind, that ours is a long-term investment.

The good news for us is \$78,000 in 2008 income is available for 2009 operating support. The anticipated 2009 and 2010 income picture is not so rosy, so it is vital that we all continue our support of the Museum and make our fund-raising activities as effective as possible. ♦

NATIONAL HEISEY GLASS MUSEUM ENDOWMENT FUND - DEC. 31, 2008

MARKET VALUE AS OF DECEMBER 31, 2007	\$2,301,576.26
MARKET VALUE AS OF MARCH 31, 2008	2,205,623.95
MARKET VALUE AS OF JUNE 30, 2008	2,156,782.17
MARKET VALUE AS OF SEPTEMBER 30, 2008	2,065,408.09
MARKET VALUE AS OF DECEMBER 31, 2008	1,870,823.40
HCA 2008 ENDOWMENT RECEIPTS	27,783.50
2008 DEPOSITS - 2007 RECEIPTS	3,520.00
2008 DEPOSITS - 2008 RECEIPTS	23,388.50
TOTAL 2008 ENDOWMENT DEPOSITS	26,908.50
AMOUNT TO BE DEPOSITED FROM 2007 RECEIPTS	0.00
AMOUNT TO BE DEPOSITED FROM 2008 RECEIPTS	4,395.00
TOTAL AMOUNT TO BE DEPOSITED	4,395.00
2007 INCOME LESS FEES	68,619.47
INCOME DRAWN DOWN FOR OPERATIONS IN 2008	68,600.00

2009 FIFTH ANNUAL HEISEY SELECT AUCTION

Dave Spahr

Last month we announced our Fifth Annual Heisey Select Auction! Thanks to all for the great support you all have given in the past for this event for HCA. Mark your calendars - the date for the auction will be **October 3, 2009**. It will be held in conjunction with the Annual Percy & Vivian Moore Dinner, which will be held in Newark this year. There will be articles about that event in future Newsletters.

The first thing you can do is to prepare a **list** of glass you would like us to **select** for this auction. We must receive your **list** by **May 18, 2009**. A blank list for you to use is on page 20 of this newsletter. Please note the blank list contains

space for twenty lots - each member is allowed to submit **forty lots** for the committee to select from. As you prepare your lists, please make them as descriptive as possible since the committee will be using them to select glass for the auction. It is very important that you carefully check for damage-we are selecting only undamaged glass for this special auction. Remember- send in **NO** glass- just the list with up to forty lots.

The committee's target is to have an auction with two hundred (200) lots. How can you get your glass selected? Here are some clues. Consideration will be given to include diversity in color, etchings, cuttings, and patterns. A main goal in the selection will be not to have any duplication of lots. We would like glass for the experienced collector who wants that exotic piece of Heisey and glass also for the fledgling collector just starting out. As mentioned earlier, we will not select damaged glass.

The selection committee will be busy and will contact you on or about June 1 to let you know the glass it has selected. Hopefully, you will be able to bring your glass to Newark and drop it off at the Museum when you come to the Convention on June 17-20. The auction will be held in the lower level in the Museum in the activity center. Please look over your glass and begin your lists soon. May 18 will be here before you know it!

Remember, this auction benefits **your** association. Consider making a donation of a piece - 100% goes to support HCA and the Museum. Donations do not count towards your 40 lot limit. We hope Study Clubs will donate glass for the auction - a great project for them!

This year, consistent with the last four select auctions, the consignment fee for each lot will be 20% with a minimum consignment fee of \$5. This means anything that sells for under \$25, the consignment fee will be \$5.

This event has been a success for consignors and those purchasing the wonderful Heisey glass. Do plan on attending and participating in this auction for the benefit of your Museum.

If you have any questions, please E-mail or call Dave Spahr, masdgs@aol.com or (937)-372-7166. Happy Heisey Hunting! ♦

2009 SELECT AUCTION GLASS LIST

FOR THE BENEFIT OF HCA

Consignor/ Owner: _____

Address: _____

Daytime Phone: (____) - ____ - ____ Fax or E-mail _____

SEND TO: Select Auction, c/o HCA, 169 W. Church St., Newark, OH 43055

DEADLINE: List must be received by May 18, 2009

Lot #	Qty	Pattern #/ Name	Description	Cut/Etch	Color	H	Damage
1							
2							
3							
4							
5							
6							
7							
8							
9							
10							
11							
12							
13							
14							
15							
16							
17							
18							
19							
20							

**Please put a "D" beside the lot number if the lot is to be donated to HCA.
Each consignor may submit up to 40 lots.**

THE LATEST 2009 HCA CONVENTION NEWS !

Judy Rhoads & Mary Ann Spahr, Co-
Chairs

Registration* and More!

Want to know what's going on? It's in the bag!
The Registration bag that is!

All registered attendees will receive MUST-HAVE ITEMS: NAME BADGES, SPECIAL COUPONS, and SCHEDULES!

Plus... Maps, brochures, booklets and goodies from the Licking County Convention and Visitors Bureau and Chamber of Commerce, "Glass Pass" information which entitles you to discounts on admission to the ten museums and attractions related to the history of the glass industry in Ohio, West Virginia, and Pennsylvania, ...and more!

You have three opportunities to pick up your Registration Bags:

- 1) The Museum - Wednesday, June 17, from 2:00 - 5:00 p.m.
- 2) The Museum - Thursday, June 18, from 10:00 a.m. - Noon
- 3) The Premiere Glass Show - Thursday, June 18, from 1:00 - 4:00 p.m.

Menus and Venues

What is the second thing a Heisey collector thinks about? Food, of course!! Here is a look at Convention events where we have an opportunity to visit during a meal.

The Welcome BBQ will be held on Wednesday, June 17, at 5:30 p.m., at a new, exciting location. Rotary Park has a lovely picnic pavilion, easy to find, off Sharon Valley Road, just east of Country Club Drive, on the south side of the road, on the northern edge of the OSU-Newark campus. It has a separate restroom building, is handicap accessible, and there is plenty of parking. Our menu for the evening is: Pulled Pork, BBQ Beef, Sweet Corn

Bake, Baked Beans, Tossed Salad, Potato Salad, Watermelon, Rolls, Cobbler, and Beverages.

During this official opening event, we will be welcomed to the area by the director of the Licking County Convention and Visitors' Bureau. First-timers will be welcomed and will meet mentors. Candidates for the Board of Directors will be given an opportunity to introduce themselves.

Plan to move from the barbecue to the Museum for a rousing game of "Heisingo," guaranteed to have you snooping into every display case. Prizes will be awarded!

Our traditional banquet occurs on Friday, June 19, with a cash bar at 6:00 p.m., and the meal at 7:00 p.m. at the Crystal Ballroom in downtown Newark at 29 W. Church St. It is a little tricky to find. Just 2 ½ blocks east of the Museum toward downtown, on the south side of the street, you will find a building that says Union Square. Inside you will find stairs and an elevator to transport you to the second floor and the charming Crystal Ballroom. The menu includes Roast Beef au jus, Chicken Cordon Bleu, Tossed Salad, Roasted Red Potatoes, Vegetable Medley, Rolls, and Dessert.

We plan on having a special auction at this event that will feature exciting and beautiful Heisey glass.

There is no better way to get to know other Heisey collectors than by chatting with them over delicious food. We hope you all register for these two events!

** Your
CONVENTION REGISTRATION FORM
Is on page 23 of this Heisey News!*

Check out the Curator's Report for information on the two seminars that are scheduled during the Convention. Your curator, Walter Ludwig is sure to present two informative programs on Heisey Etchings. ♦



38th Annual Convention
HEISEY COLLECTORS OF AMERICA, INC.
 JUNE 17-20, 2009

"Artistry in Glass: the Heisey Etchings"

SCHEDULE of EVENTS

Event	Time	Location
WEDNESDAY, June 17		
Registration Pickup	2:00 - 5:00 p.m.	Museum
<i>"Tally Ho"</i> ...and off we go ... Welcome BBQ	5:30 p.m.	{ Rotary Park Sharon Valley Rd Newark
Museum "Heisingo"	8:00 p.m.	
THURSDAY, June 18		
Registration Pickup	10:00 – Noon	Museum
<i>"You, Me, Us"</i> Study Club Representatives meeting	10:00 - 11:00 a.m.	Founders Hall Auditorium
Glass Show tickets sales begin	11:30 a.m.	Adena Hall, OSUN/COTC
Show Preview (<i>Convention Registrants Only</i>)	Noon - 1:00 p.m.	Adena Hall
Glass Show open – General Admission	1:00 - 7:00 p.m.	Adena Hall
Registration Pickup	1:00 - 4:00 p.m.	Adena Hall
Seminar	3:00 p.m.	Adena Hall
Glass Identification Session / Show & Tell	8:00 p.m.	Founders Hall Auditorium
FRIDAY, June 19		
<i>"Good Morning"</i> Annual General Membership Mtg	8:30 a.m.	Founders Hall Auditorium
Glass Show open – General Admission	Noon - 5:00 p.m.	Adena Hall
Former Employees Reunion	1:00 - 2:00 p.m.	Museum
Seminar	3:00 p.m.	Adena Hall
<i>"Tavern"</i> Cocktails (cash bar)	6:00 - 7:00 p.m.	{ The Crystal Ballroom 29 W Church St Downtown Newark
<i>"Classic"</i> Heisey Banquet / Special Auction	7:00 p.m.	
SATURDAY, June 20		
Flea Market on the Square	8:00 a.m. – Noon	Courthouse Square Downtown Newark
Glass Show open – FREE ADMISSION	Noon – 5:00 p.m.	Adena Hall

OPEN HOUSE

The National Heisey Glass Museum
 Tuesday – Saturday, June 16-20, 10:00 a.m.- 4:00 p.m.
 Sunday, June 21, 1:00-4:00 p.m.

Hospitality in Multipurpose Room, Thursday & Friday, 10:00 a.m. – 4:00 p.m.



HCA CONVENTION 2009 REGISTRATION FORM

REGISTERING IS EASY !

Forms are available in your Heisey News and online at www.HeiseyMuseum.org

1) **Mail** forms to Convention Registration, 169 W Church St, Newark OH 43055; 2) **Deliver** forms directly to the Museum; 3) **Phone** in registration information at 740-345-2932; or 4) **Fax** forms to 740-345-9638 !

- ◇ **Registration deadline Thursday, June 4**, for all food events. Sorry, **no registration refunds after June 8** when final counts are taken!
- ◇ If you are not registering the same people for all events, or individuals are from different locations, please fill out a separate form for each person.
- ◇ If you want notice of confirmation, you must include a SASE or provide an E-mail address below.

Please print each name as it should appear on their badge:

Name(s): _____

Address: _____

City / State / Zip _____

Phone: (____) _____ E-mail: _____

Check here to receive E-mail confirmation of your registration

IS THIS YOUR FIRST HCA CONVENTION? _____ WOULD YOU LIKE A MENTOR? _____
 OLD TIMERS, PLEASE APPROXIMATE the YEAR OF YOUR FIRST CONVENTION ! _____

PAYMENT: Cash Check
 MasterCard Visa # _____ exp _____

Event	How Many?	Cost	Subtotal
Registration Fee (Deadline Thursday, June 4)	_____ X	\$25 -	_____
*Welcome BBQ, Wednesday, 5:30 p.m. <i>Pulled Pork, BBQ Beef, Sweet Corn Bake, Baked Beans, Tossed Salad, Potato Salad, Watermelon, Rolls, Cobbler</i>	_____ X	\$12 -	_____
Thursday Seminar: "The Heisey Etchings"	_____	FREE	
*Glass ID Session / Show & Tell	_____	FREE	
Annual Meeting, <i>Open to all HCA Members</i>	_____	FREE	
*Former Employees Reunion	_____	FREE	
Friday Seminar: "The Heisey Etchings"	_____	FREE	
*Heisey Banquet / Auction, Friday, 6:00 p.m. <i>ROAST BEEF AU JUS, CHICKEN CORDON BLEU, TOSSED SALAD, ROASTED RED POTATOES, VEGETABLE MEDLEY, DESSERT</i>	_____ X	\$25 -	_____
Flea Market on the Square	_____	FREE	
Hospitality Room, Thursday & Friday at Museum	_____	FREE	

**You must be registered to attend these events !*

TOTAL - \$ _____



HEISEY GLASS MUSEUM PLAYING CARDS

Edition 3 (green deck) of Heisey Glass Museum Playing Cards are now in. In addition, we have for sale a limited number of uncut sheets (21" x 25") which will be suitable for framing. This deck features the Heisey animals and animal related items. The full color pictures are stunning and will make a good learning tool as well as a nice gift for all of your glass collecting friends. We will ship as soon as available. Orders for Card Cases (Cobalt) and the Red deck may also be placed on this form.

Name _____
 Address _____
 City _____ State _____ Zip _____
 Phone and/or E-mail _____

I wish to order:	Total
_____ (number) Heisey Glass Museum Playing Cards (Green) @ \$10 each	_____
_____ (number) Heisey Glass Museum Playing Cards (Red) @ \$10 each	_____
Shipping per deck \$ 1.50 (can be picked up at Gift Shop)	_____
_____ (number) Uncut sheets of Heisey Playing Cards (Green) @ \$25 each	_____
_____ (number) Uncut sheets of Heisey Playing Cards (Red) @ \$25 each	_____
Shipping per uncut sheet @ \$5.00 each (can be picked up at Gift Shop)	_____
_____ (number) 1508 Card case in Cobalt @ \$24.95 each	_____
Shipping per card case @ \$6.00 each (can be picked up at Gift Shop)	_____
Grand Total (tax will be added when appropriate)	_____

Check # _____ Visa _____ Master Card _____
 Card Number _____ Exp _____

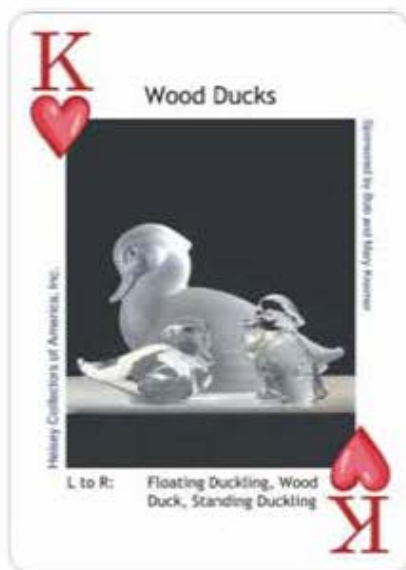
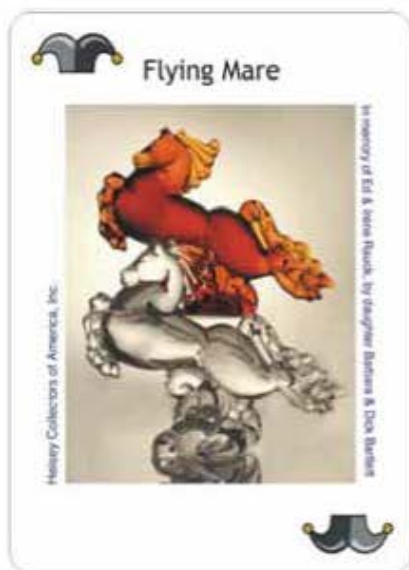



CLUB NOTES

Heisey Club of California
Bill Brakemeyer

All interested parties may participate in raising monetary support for Heisey Collectors of America through a benefit fund-raiser to be held April 26, 2009.

Donation chances in an HCA Benefit Fund-raiser will be offered. Each chance in the fund-raiser will be purchased for ten dollars (\$10). Participants may purchase chances in the fund-raiser by mail or in person. There will be no limit to the number of chances a person may purchase. Chances will be available from HCC by check, money order, or cash. All checks and money orders must be designated 'Donation to HCA.' Receipts for cash donations will be given to donors. Checks and money orders should be sent to Heisey Club of California, 2214 Drummond Street, Riverside, California 92506-1532. Mail entries must be received by April 23, 2009.

Seventy percent (70%) of the total amount raised through donation chances will be given to HCA at the 2009 Annual Convention/Meeting in Newark, Ohio. Thirty percent (30%) will be divided among the fund-raiser tickets drawn.

Three tickets will be drawn during the April 26, 2009 club meeting. The first ticket will be awarded fifteen percent (15%) of the total proceeds collected. The second ticket (drawn later) will be awarded ten percent (10%) of the total proceeds. The final ticket will be awarded five percent (5%) of the total proceeds. Winners do not have to be present at the drawing to win. ♦

Advertising Guidelines:

Advertising: Ads may be mailed to: HCA Advertising, 169 W. Church St., Newark, OH 43055; faxed to (740) 345-9638; or e-mailed to curator@HeiseyMuseum.org. Whenever possible, please e-mail your ad. Include your MasterCard or VISA number and expiration date for billing purposes, or send a check. All ads must be prepaid. When mailed or faxed, ads should be typed or printed on white paper with dark ink. Please double space. Ads that are entered in a vertical column format may contain a maximum of 65 characters per line, including spaces & punctuation.

Classified: 20 cents per word (members), 30 cents per word (non-members), \$1.50 min., 1/8 page limit. Personal ads 1/8 page limit. Abbreviations & initials count as words.

Display Ads:	member	nonmember
1/8 page (12 lines)	\$ 20	\$ 30
¼ page (25 lines)	\$ 40	\$ 60

½ page (60 lines, horizontal or vertical)

\$ 80 \$120

Full page (120 lines) \$160 \$240

A charge of \$1.60 will be added for each additional line.

½ page: 4½" high by 7½" wide or 9" high by 3½" wide

Full page: 9" high by 7½" wide

Ad copy must be received by the first of the month prior to publication. Reproductions (i.e., Heisey by Imperial) must be indicated. Heisey News accepts no further liability. In the event of a typographical error, the incorrect portion of the ad will be run in the following issue, but HEISEY NEWS assumes no further liability.

Abbreviations: DF = Dolphin Foot NO = Narrow Optic
DO = Diamond Optic SO = Spiral & Saturn Optic
MO = Medium Optic WO = Wide Optic

Classified Ads

For Sale: Heisey Rose etch collection, approximately 350 pieces. Please call 479-452-0943 or e-mail ParsonsSkeeter51@aol.com.

♦ *Paid Ad*

REAL HEISEY IN THE GIFT SHOP

All crystal and all prices are each unless noted.

Supply changes daily. Please contact the Gift Shop before placing an order.

Item	Price
343 Sunburst butter top only H	25
351 Priscilla butter pat, H	10
394 Narrow Flute 4 ½" chow chow, H	25
411 Tudor cruet, H	35
411 Tudor punch cup, H (4 each)	5
417 Double Rib and Panel cruet, H	20
475 Narrow Flute/Rim salted nut, plain bottom H	15
1170 Pleat and Panel luncheon goblet (2 each)	10
1183 Revere individual salt (4 each)	12
1225 Plain Band table sugar lid	15
1401 Empress plate, 8" sq, 448 Old Colony, Sahara, H (4 each)	15
1404 Ipswich sherbet (2 each)	10
1483 Stanhope cream/sugar, no knobs, H	30
1483 Stanhope cup, no knob (6 each)	15
1503 Crystalite shell mayonnaise	10
1503 Crystalite cruet	15
1509 Queen Ann DF creamer	5
1509 Queen Ann Cup/saucer, H	5
1509 Queen Ann 10 ½" dinner plate	15
1519 Waverly pickle/olive	10
1519 Waverly 12" celery, H	5
1519 Waverly 10" deep salad bowl	15
1519 Waverly triplex relish	10
1519 Waverly twin dressing, H	15
1519 Waverly 8" plate (3 each)	5
3350 Wabash plate, 6", Flamingo (4 each)	5
3440 Portsmouth goblet, Moongleam ft (3 each)	20

Kim Carlisle
28220 Lamong Rd.
Sheridan, IN 46069

P&I \$6.00 all orders
317-758-5767
kcarlisl@att.net

365 Rhombic ashtray Flamingo	\$125
3390 Carcassone flagons Alexandrite (6 each).	325
477 Hairpin basket w/fancy cutting	975
5072 Rose stem cocktails Rose etch (6 all)	125
1469 1/2 Ridgeleigh 8" vase Sahara	200
1567 Plantation 18" buffet plate	145
1567 Plantation cigarette box & cover	550
1428 Warwick 9 in. vase w/Calcutta cut	325
4227 Favor vase, Sahara	250
1280 Winged Scroll crystal toothpick, some gold	275
4231 Favor vase, Moongleam	650
1405 Ipswich popcorn bowl (like 1404 popcorn bowl)	1,250
1404 Old Sandwich shot glass Moongleam	275
1404 Old Sandwich 1/2 gal. jug Flamingo	325
1401 Empress 3 pint D.F. jug Flamingo	275
1401 Empress 3 pint D.F. jug Moongleam	325
1401 Empress 8 oz. D.F. tumblers, Flamingo (6 ea)	250
1401 Empress 8 oz. D.F. tumblers Sahara (6 ea)	225
1401 Empress salt & pepper, both Alexandrite	450
417 Dbl Rib & Panel basket cut Flamingo	250
417 Dbl Rib & Panel basket cut Hawthorne	675
500 Octagon crystal basket w/fancy cutting	850
1401 Empress 9 oz. goblets Flamingo (6 each).	145
350 Pinwheel and Fan 8" bowl Moongleam	325
1430 Aristocrat low-footed candy, no cover Cobalt	350
339 Continental water bottle Flamingo	225
71 Oval candlestick w/Windsor cutting	225
4035 Bethel decanter w/Fisherman etch & cut stopper	300
4036 Marshall cock shaker w/Tally Ho Rooster stopper	250
4225 Cobel qt cocktail shaker w/Fisherman etch	300
3408 Jamestown bell w/Minuet etch	160
1183 Revere 2 compartment dressing w/Rose etching	150
4164 Gallagher jug w/Empress etch Mgld, some crazing	225
3368 Albemarle 8 oz. goblets Moongleam (8 each).	30
4225 Cobel qt. cocktail shaker Short Sailboat etch	325
3359 Plateau 1/2 gal. jug Flamingo	125
3355 Fairacre 54 oz. jug, Moongleam ft & hdl	260
3357 King Arthur 54 oz. footed jug all Flamingo	235
3362 Charter Oak 1/2 gal jug Flamingo	175
1425 Victorian 27 oz. Rye bottle #99 stopper (2 each).	110
4206 Optic Tooth 8" vase Flamingo	150
15 Flower frog and Duck insert, 2 pc. crystal	275
14 Kingfisher flower frog, crystal	325
367 Prism Band decanter, Moongleam, crystal stopper	250
367 Prism Band decanter, Flamingo crystal stopper	250
2517 Teardrop Flamingo pitcher Flamingo	275
1433 Thumbprint & Panel vase Flamingo	325
4 Essex candleholders, pr	425
463 Bonnet basket, Flamingo w/Cloister cutting	1,250
429 Hartman covered candy w/cutting	95
3480 Koors Flamingo pitcher	125
1511 Tourjours Apple marmalade w/Minuet etch	150
1540 Lariat Blackout lamps and shades, pr	950
393 Narrow Flute hollow stem champagnes (2 each)	30
1519 Waverly 3 light candleholders w/Rose etch pr.	225
4206 Optic Tooth Flamingo pitcher	175
1210 Frog handled cheese plate, crystal	150
3380 Old Dominion Marigold cordial w/Empress etch	375
3389 Duquesne cordial w/Botticelli cut	185
1483 Stanhope cruet Red knob w/Frosty Dawn etch	325

◆ Paid Ad

Erma & Rodger Hulslander
1427 Ridgeview St.
Mesquite, TX 75149

(972) 289-6159
USPS Extra
heiseyhouse@att.net

Will E-mail pictures!

4227 Favor vase Sahara	\$130
4227 Favor vase Crystal	110
4228 Favor vase Crystal	110
4229 Favor vase Crystal (Blue foil label on bottom)	110
4231 Favor vase Crystal	110
1504 Regency 3" candle blocks, Pr.	80
135 Empress candlesticks, Pr. with cutting Sahara H	130
1401 Empress D.F. 6" candlesticks, Pr. Sahara H	170
1401 Empress D.F. 6" candlestick Moongleam (1) H	140
77 Duck Stopper, for cologne, Crystal	70
77 Duck Stopper, for cologne, Flamingo	85
77 Duck Stopper, for cologne Moongleam	95
30 Tom Thumb, min. 3" pr. candlesticks H	75
3304 cocktail icer & liner, Dolly Madison Rose cut	125
4224 Ivy vase, (10 Optics) Tangerine	140
2 Goose Wings Half	40
1529 Balking /Rearing Colt	100
86 stand lamp (kerosene), with a "B" fount, 10 in. base, # 8 bobèche, 12-6 1/2" C prisms, #51 ferrule & #2 collar, nickel plated, #2 duplex burner (with globe ring). H	1500

Wanted #341 Puritan 2# candy Jar!

◆ Paid Ad

Find the Best of Heisey Glass...

...with popular patterns like Orchid, Heisey Rose, Minuet, and hundreds more. We also carry other fine crystal and depression glass from Cambridge, Fostoria, Imperial, Duncan & Miller, and more. The world's largest supplier of old and new china, crystal, flatware and collectibles, Replacements, Ltd. carries over 11 million pieces in inventory in over 250,000 patterns.

If you're looking to add to your collection, or if you're looking to sell — call us toll-free. We're always looking for more.

 **REPLACEMENTS, LTD.**
China, Crystal & Silver • Old & New
Dept. HS, PO Box 26029, Greensboro, NC 27420
www.replacements.com

1-800-REPLACE (1-800-737-5223)

◆ Paid Ad

Dealer Directory

Maximum 6 lines/12 months/\$35 MEMBERS ONLY

Contact the Editor to place your ad!



<p>KIM & PAM CARLISLE SHOWS & MAILORDERS ONLY 28220 Lamong Rd. Dept. H Sheridan, IN 46069 Glass Cleaning Services Available (317) 758-5767 kcrlis1@worldnet.att.net</p>	<p>SHIRLEY EUGENIA DUNBAR Heisey a Specialty—Mail Order, Shows, Appraisals EMAIL: shirley400@aol.com PO Box 8344, Port St. Lucie, FL 34952 Oct-May (772) 337-1558 PO Box 222, Naples, ME 04055 May-Oct (207) 647-5652</p>	<p>SUM OF LIFE Elaine Husted: 610-469-1243 Traveling through eastern PA Call, stop in, be a buyer or a browser!! E-mail: 1classycat@comcast.net</p>
<p>ALL HEISEY AUCTION Consignments Welcome Apple Tree Auction Center 1616 W. Church, Newark, OH 43055 (740) 344-4282</p>	<p>MOUNDBUILDERS SECOND GENERATION Barbara and Richard Bartlett Heisey Exclusively! 1-904-280-0450 PO Box 1931, Ponte Vedra Beach, FL 32082 Toll Free 1-888-434-7397(HEISEYS) EMAIL: CLASYGLAS2@AOL.COM</p>	<p>EAGLES REST ANTIQUES Buying Heisey, China & Pottery Carl and Mary Evans 62 Fieldpoint Rd., Heath, OH 43056 (740) 522-2035</p>
<p>PAULA & JEFF MORROW Elegant Glassware and American Dinnerware 126 Clinton Avenue Elmhurst, IL 60126 (630) 833-4644 mor-fab@comcast.net</p>	<p>H & R DIAMOND H Helen & Bob Rarey 1450 White Ash Dr. Columbus, OH 43204 (614) 279-0390 after 5:30</p>	<p>CRYSTAL LADY Bill, Joann & Marcie Hagerly Specializing in elegant depression glassware 1817 Vinton St., Omaha, NE 68108 Shop (402) 341-0643 or Home (402) 391-6730 Email: ejhagerly@aol.com website: www.crystalladyantiques.co</p>
<p>REALMS IN GLASS Roy Eggert Heisey Custom Stained Glass 12009 Fingerboard Rd, Monrovia, MD 21770 301-865-5196 roy54@hughes.net</p>	<p>PIECE BY PIECE ANTIQUES Buy & Sell Specializing in Heisey Glassware Bryan K. Baker Fairfax Station, VA 22039 Newark, OH 43055 (703) 250-6117 piecebypiece@verizon.net</p>	<p>PATTON HOUSE ANTIQUES Specializing in Glass*Heisey*Cambridge*Fostoria*Duncan* Factory Antique Mall, Verona, VA off I-81 Exit 227 Antiquers Mall, Booth 81, Rt. 29 N., Charlottesville, VA The Daniels, Box 547, Louisa, VA 23093 (540) 967-1181</p>
<p>C&J ANTIQUES Cole & Jean Miesner Box 45, 72 Whig St. Newark Valley, NY 13811 (607) 642-9905</p>	<p>SIBYLS OF WILMINGTON Sibyl & Ned Lavengood at Castle Corner Antiques 555 Castle St. Wilmington, NC (910) 264-9597 or Sibylsantiques@bellsouth.net</p>	<p>FRAN'S FANCY FINDS Fran & Jack Grenzsbach 10534 Valencia Rd., Seminole, FL 33772-7511 (727) 391-5184 SHOWS MAIL ORDERS</p>
<p>The American Bell Association P.O. Box 19443 Indianapolis, IN 46219-0443 www.americanbell.org m</p>	<p>PASTICHE ANTIQUES at Preston's Antique Gaslight Village US 12, Allen, MI 49227 Elegant Glass and Other Fine Antiques pasticheantiques@gmail.com</p>	<p>WILLEY'S ANTIQUES & MUSEUM Specializing in Heisey 11110 Cannon Rd., Frazeeburg, OH 43822 16 miles east of Newark, OH (740) 828-2557</p>
<p>CHARLES & MILDRED FISHER Heisey animals and Heisey By Imperial animals 1607 Dayton Rd, Newark, OH 43055 Cfisher08@roadrunner.com (740) 281-3104</p>	<p>MARSH'S ANTIQUES Dick and Virginia Marsh 4532 Newton Road Newark, OH 43055 swamp@alink.com (740) 366-5608</p>	<p>MOONGLEAM ANTIQUES Heisey Glassware & American Art Pottery John Woytowicz and Peter Rivard 70 Pleasant St., Gardiner, ME 04345 (207) 582-9048 E-mail: jmwpwr@aol.com</p>
<p>ROBERT M. LOCH Voting Member HCA and NWHC Pacific Interstate Glassware Co. PO BOX 469 Custer, WA 90240 360-366-3166</p>	<p>CRESTONE MANOR UNIQUES Harold & Loleta Hammontree 3317 Crestone Circle, Chattanooga, TN 37411 423-629-1274 hammonl@bellsouth.net Heisey Only</p>	<p>APPLE VALLEY COLLECTIBLES Richard & Marilyn Garnett – Owners Shows/ Mail Order (845) 691-6308 Email: diamondh95@aol.com</p>
<p>DOWNSTAIRS AT FELTON ANTIQUES 100B Felton St, Waltham, MA 02453 781-894-2223 info@feltonstreetantiques.com GLASSWARE, POTTERY, EPHEMERA, STERLING, FURNITURE FROM EVERY DECADE!</p>	<p>WM GLASS Bill & Mary Barker 400 Nantucket Ave., Pickerington, OH 43147 (740) 927 0918 mcbarker@embargo.com Heisey Only</p>	<p>WATERSEdge ANTIQUES Norene & Don Walzer Shows & Mail Order 25089 Riverwalk Drive Leesburg, FL 34748 (352) 314-8975 dinwalzer@zembargmail.com</p>
<p>JERRYS' ANTIQUES Shows Only Glassware and Other Fine Collectables PO Box 4485, Davenport, IA 52808 563-340-1871 jerrysantiques@mchsi.com</p>	<p>ONCE AND FUTURE ANTIQUES Susan & Stephen Pescatore 9 Donna Rd. Chelmsford, MA 01824 (978) 256-5418 Heisey and Elegant Glass</p>	<p>BOB & MARY KREIMER Specializing in Heisey Glass 7044 SW 116th Loop, Ocala, FL 34476 (352) 873-8306 email: rkreimer@earthlink.net Shows and Mail Orders Only</p>
<p>J & L TREASURES Specializing in Heisey, Cambridge, Fostoria, Tiffin, Morgantown, etc Linda Kilburn, PO Box 1257, Burlington, CT 860-673-4088 jltreasures@comcast.net</p>	<p>Charlene Bowman Shows Only Heisey – Cambridge – Fostoria - Morgantown P.O Box 287, Clarksville, OH 45113 937-289-2114 twoclbs@aol.com</p>	<p>YELLOW BRICK ROAD ANTIQUES Jean Will Leavenworth, KS 66048 (913) 682-4831 Specializing in Heisey and Elegant Glassware Shows and Estate Sales</p>
<p>Just in Time Antique Mini Mall 29 North Third St Newark, OH 43055 Heisey in Stock 740-349-0001 ntleblanc@aol.com</p>	<p><i>Your Ad Could be Here</i></p>	<p><i>Your Ad Could be Here</i></p>

When Renewing Your Membership

Help ensure the future of your Museum. When you renew your membership at one of the levels below, any amount beyond the regular Associate dues goes into the Endowment Fund.

<i>Individual Contributing, one person in household</i>	<i>\$50</i>
<i>Joint Contributing, two people in one household</i>	<i>\$60</i>
<i>Family Contributing, parents and children under 18</i>	<i>\$75</i>
<i>Patron</i>	<i>\$125</i>
<i>Sponsor</i>	<i>\$250</i>
<i>Benefactor</i>	<i>\$500</i>

Visit The
National
Heisey
Glass
Museum



Come at your leisure to enjoy more than 4,800 pieces of glassware produced by A.H. Heisey and Company from 1896-1957. Hundreds of patterns are featured in all production colors. Rare and experimental items are included as well.

Facilities are air-conditioned and handicapped-accessible. Hours are 10:00 a.m. to 4:00 p.m. Tuesday through Saturday, 1:00 to 4:00 p.m. Sunday (except Jan. and Feb.). Members are admitted free, regular admission is \$4. Office hours are 8:00 a.m. to 4:30 p.m. weekdays.

Membership Renewal Notice: Check the date above your name and address on the mailing label. This is your expiration date. If it reads 4-10-09, make sure your dues are paid soon in order to receive next month's issue of *Heisey News*.

Contact the HCA Administrative Office at (740) 345-2932 for more information. The Endowment Committee wishes to thank those who have become Endowment Members and all of the individuals and study clubs that have so generously supported the HCA Endowment Fund. All members who have supported the fund are recognized each year in the February issue of the Newsletter. Your support will make the Museum self-sustaining in the years to come. Thank You all! ♦

Shipping & Handling Fees for Outside US

Additional shipping charges are required for members living outside the U.S. Current rates are Canada, \$22; for other countries, contact the Museum. Rates are subject to change at any time due to rate changes made by the US Postal Service. To verify current rates, call (740) 345-2932 or E-mail business@HeiseyMuseum.org



Periodical Postage

Paid at the Post Office
In Newark, OH 43055
Publication # 00986
POSTMASTER SEND FORM 3579 TO:
HCA
169 W. Church St.
Newark, OH 43055

To: _____

Museum Volunteers for February 2009

Chuck & Amy Jo Jones
Dick Marsh
Phyllis McClain
Don & Pat Moore
Ginny Priest
Bob Rarey
Russ Reopell
Judy Rhoads
Dick & Jocelyn Ritter
Dick & Marilyn Smith
Dave & Mary Ann Spahr
Charlie Wade