HEISEY NEWS

P.O. Box 4367, Newark, OH 43055

CLUB OFFICERS:

President - Bob Rarey (614) 279-0390
Vice President - Dick Smith (614) 366-5163
Secretary - Liz Stickle (614) 323-2250
Treasurer - Mary McWilliams (614) 345-4380
Curator - Louise Ream

Editor: Louise Ream
P.O. Box 4367, Newark, Ohio 43055
PH: (614) 345-2932

Published in Newark, Ohio, Printed in Newark, Ohio.

\$15.00 per year - \$1.25 per copy

Back Issues - Each Volume (12 issues) year - \$9.00
Volume V, VIII, IX, X, XI, XII, XIII, XIV, XV, XVI

Heisey Collectors of America, Inc. is a non-profit corporation with tax exempt status. Owners and operators of National Heisey Glass Museum, 6th and Church Streets, Newark, Ohio.

Open daily 1-4 p.m. except holidays. Other hours by appointment. Members admitted free.

HEISEY NEWS

Heisey Collectors of America, Inc.

All Rights Reserved 1989 - ISSN 0731-8014

Published monthly, except twice in February, by Heisey Collectors of America, Inc., Newark, OH 43055. Second Class postage paid, Newark, Ohio 43055. Club membership (includes 13 issues of Heisey News and participation in all club activities) \$15.00 per year plus \$2.50 for each additional family member in same household who wishes a membership card. For Voting Membership add \$25.00 one time only fee.

POSTMASTER: Send address change to:
HCA, P.O. Box 4367, Newark, OH 43055

When requesting information, please enclose a self-addressed, stamped envelope (SASE).

ADVERTISING - Send all ads to: HCA - Advertising
P.O. Box 4367
Newark, Ohio 43055

DOUBLE SPACE ALL ADS

Rates:

CLASSIFIED: 15¢ per word. \$1.50 minimum.

ABBREVIATIONS AND INITIALS COUNT AS WORDS

DEALER DIRECTORY: \$25 per year.

Display:	Members:	Non-Members:
1/8 page (9 items)	\$20.00	\$ 30.00
1/4 page (20 items)	30.00	45.00
1/2 page (20 items) Hor.	45.00	67.00
1/2 page (50 items) Vert.	60.00	90.00
1 page (50 items)	75.00	112.50

Personal ads limited to 1/8 space.

ALL ADS MUST BE PREPAID. Ad copy must be received by the 5th of the month preceding the publication date-i.e. April 5th for May issue. Ads containing reproductions will not knowingly be accepted unless clearly stated (i.e. Heisey by Imperial, etc.). HEISEY NEWS assumes no responsibility for false advertising or misleading information. In the event of typographical error, the incorrect portion of the ad will be run in the following issue, but HEISEY NEWS assumes no further liability.

The opinions expressed in articles in HEISEY NEWS are those of the authors and not necessarily those of the organization. The Editorial Staff reserves the right to edit or refuse any material submitted for publication. When requesting information, please enclose a self-addressed stamped envelope (SASE).

STUDY CLUBS - PLEASE NOTE

The Study Club Reports and presentation of gifts to HCA will be held at the Banquet on Friday night this year. Please try to attend.

COOKIES, COOKIES, WE NEED COOKIES!

We are all looking forward to the delicious cookies which many of you will be bringing to the museum to be used in the hospitality lounge. As always the Dairyland Heisey Club of Wisconsin will be bringing Wisconsin cheese and crackers to go with the cookies. Both of these are always a big hit in the museum lounge.

GET YOUR COPY IN EARLY FOR JULY

The date for delivering our July newsletter copy to the printer is June 15, so we must have all of your articles, club notes, ads, etc. in early to be printed in that issue. The 5th of the month is the absolute deadline and we would appreciate having it earlier if possible.

This is a very busy time for us here, getting ready for convention along with everything else. Please forgive us if the July issue is a little late. We will do our best.



IF PHYLLIS McCLAIN IS NOT AT THE MUSEUM WITH CONVENTION PACKETS WHEN YOU ARRIVE, SHE WILL HAVE THEM WITH HER AT EACH EVENT.

FROM YOUR PRESIDENT

Dear HCA Members,

HCA was proud and pleased to host the semi-annual meeting of the National Glass Clubs at the museum on April 22. Representatives of the Cambridge, Fenton and Imperial Clubs were present. HCA was represented by Louise, my wife, Helen, and myself for the very informative meeting. We had hoped for a better representation of the member clubs. Problems discussed were those common to all clubs. The National Glass Club sponsors the joint membership ad appearing monthly in the Daze. A special "tip of the hat" to the two ladies from Wisconsin who were here representing the Fenton Club.

The last Executive Committee meeting concerned mostly routine matters. A contract for the installation of the walk from the front of the museum to Church Street has been signed. The contract also includes some sidewalk repair along Church Street. The erecting of the fence along Church Street was put on hold, due to lack of posts. We hope to solve this problem prior to the Convention. Lawn restoration and care has also been contracted.

I would be remiss at this time if I failed to offer my gratitude and thanks and, those of the Club, to the five members who are leaving the Board at the close of the Annual Meeting in June.

Charlie Baird chose not to be a candidate due to difficulties in arranging his schedule to make Board Meetings.

Betty Barnard, who setup our loan arrangement with Banc Ohio while Club Treasurer, chose not to be a candidate.

Mary McWilliams, Club Treasurer, is prohibited by the Constitution from seeking reelection as she has served two consecutive terms on the Board.

Liz Stickle, Club Secretary, is now employed full-time and declined to seek reelection. Liz was the driving force instrumental in getting the membership roll and museum glass inventory on our computer.

Charlie Wade, immediate past President, asked not to be a candidate because of business commitments.

You have all been dedicated "team players" and invaluable help to me during my tenure in office. All have assured me of their continued support and help. The experience and commitment of these five Board Members will be sorely missed. I am confident that the five to be elected will bring new ideas and commitment to fill the vacancies of the retiring Board Members.

As I write, the Convention - Annual Meeting is only five weeks away. Time passes quickly so I urge you to get your registration in as early as possible. Hope to see all of you at the Convention June 15 thru 18.

Merry Christmas in June
Bob Raruy

DATES TO REMEMBER

- JUNE 9, 10, 11 IMPERIAL CONVENTION
- JUNE 9, 10, 11 FOSTORIA CONVENTION
- JUNE 15, 16, 17, 18 HEISEY CONVENTION

FROM THE DESK OF THE EDITOR

We should have had the Convention now, this second week in May, since we had some snow which would have made our theme a little more authentic. However, enough Christmas planning is being done that you will all feel as though it is Christmas, even if it is 80 or 90 degrees when you get here. It promises to be an interesting theme.

Right now, all of us who work at the museum, and those involved in the planning, have the feeling that we'll never be ready in time. Of course, we always feel that way and so far, we have always made it.

If you have never been here for a Convention you have a great treat coming, and if this is your first visit to the museum you will be overwhelmed by the beauty, both of the building and of the glass, as most people are whether they are Heisey collectors or not. Please make this your "home away from home" while you are here.

Be sure to order your 1989 Oscar before the 15th or purchase it here before that date. On the 15th of June they will go up to \$25 and the general public can also buy them. Until that date they remain at \$22 and are sold to members only.

I will be very pleased to see my old friends, many of whom have attended every Convention since 1972. I will also be glad to meet those of you who are first-timers. When I am not in one of the meetings I will be at my office in the museum. You may bring any gifts of glass which are not to be presented at the dinner on Friday evening. If I am not here my secretary, Pat Hildebrand, will accept these gifts and give you receipts.

We have a few copies of the Heisey Stems book written by Stephen Bradley and Bob and Connie Ryan. Part of these are seconds which we are selling for \$14 and the remainder are \$20. Bob recently found these in his basement.

We also still have copies of the second printing of the Encyclopedia of Heisey Glass Vol. I Etching and Carvings by Louise Ream, and Tom & Neila Bredehoft. These sell, along with the 40 page addendum to the book, for \$19.95. They picture over 250 etchings and carvings. Order from HCA Sales, P.O. Box 4367, Newark, Ohio 43055.

Both of these books are available for sale at the Convention - the gift shop in the museum and the club booth at Adena Hall. HCA has a booth at the show again this year.

The article on Duncan Glass will not fit in this issue of the newsletter so it will appear later.

We will also soon be having five new glass items for sale in Teal/Blue and Ruby. We hope they will be here by Convention time. We will list them in the next issue so that you will have a chance to order them. Happy Holidays,

- JUNE 22, 23, 24, 25 CAMBRIDGE CONVENTION
- JULY 8, 9 NDGA CONVENTION
- JULY 22, 23 DUNCAN CONVENTION
- AUGUST 1, 2, 3, 4 FENTON CONVENTION
- AUGUST 12, 13 ANNUAL SOUTHERN IL HCC SHOW & SALE, BELLEVILLE, IL

WALTER VON NESSEN

by Tom Felt

In the July 1936 issue of Crockery and Glass Journal, there was a full page announcement that "Heisey's newest pattern, a startlingly beautiful creation by Walter Von Nessen, one of America's foremost designers, will be introduced at the New York show, July 19 to 25, and at the Chicago show, August 3 to 15. Don't miss this. It is sure to be a big winner!" The line being heralded was no. 1483 Stanhope and it was the first of four patterns created by Von Nessen for Heisey in the 1930's. Most Heisey collectors today associate this designer with these patterns, all of which, like Stanhope, typified the Art Deco period.

So I was quite interested a couple of years ago when I went to an Art Deco exhibit at the Renwick Gallery in Washington, D.C., and found that Walter Von Nessen was prominently featured for his work in lighting, furniture and accessories in metal. His association with Heisey seems to have been his only foray into glassware design and while some of his work during this period was certainly in the "modern" (i.e., Art Deco) style, not all of it was really representative of the kinds of creations he was so well known for in other media.

There were two main movements which can be considered Art Deco. The first, dating from the early 1900's, originated in Austria and Germany and, according to Alastair Duncan, author of American Art Deco, "it placed emphasis on functional design applicable to mass production. Ornament was given only secondary status." This movement, often referred to as "Modernism," is the one to which Von Nessen primarily belongs, and it had a powerful influence on American design, though not really until the late 1920's.

Prior to that, beginning in the years immediately following the First World War, there was another movement which is the one we most readily identify with Art Deco today, "the highly colorful and playful style" from France which "arrived in the United States before the older, more austere, Austrian/German variation."¹ There was a parallel development of the two styles in the United States through the 1930's, but with the latter gaining more commercial popularity (no doubt to a great extent due to the work of the Hollywood designers who tantalized audiences with an Art Deco fantasy world in the musicals and comedies of the time). For this reason, I suspect there were commercial pressures that edged some of Walter Von Nessen's work for Heisey away from his usual Modernism in the direction of the more ornamental and less austere designs he created in glassware. This is certainly true in the case of no. 1495 Fern, which is almost "fussy" in comparison with no. 1483 Stanhope or no. 1485 Saturn.

Walter Von Nessen was born in Germany in 1889 and studied in Berlin with Bruno Paul, "an important educator and furniture designer."² One of Von Nessen's earliest commissions involved redesigning the interiors of Berlin's subway stations. He also taught at the Charlottenberg Art School and, from 1919 to 1923, lived in Stockholm, where he designed furniture for various Swedish clients.

In 1923 he emigrated to the United States. In the mid-1920's he established the Nessen Studio at 151 East 38th Street in New York, a small company

that supplied architects and interior designers with lighting fixtures and other innovative metal furnishings. From the very beginning, he found himself in the forefront of the developing modernist style in this country. For instance, in 1926 he provided metal lamps on either side of the main doorway of the Lowell, an apartment house on East 63rd Street, which is now recognized as one of the first public buildings in New York to incorporate characteristics of the style in architecture we now consider to be Art Deco. His lamps were also used by Eliel Saarinen in the Cranbrook Academy of Arts in Bloomfield Hills, Michigan, a project which is still considered one of the landmarks in modern design. By 1928, he was well enough known to be included as one of the exhibitors in an "International Exposition of Art in Industry," sponsored by Macy's. Richard Beach, director of industrial relations at the Metropolitan Museum of Art, wrote of this show that it "closes a chapter in the history of contemporary art. The modern style . . . has come to stay."³

By 1930, when most firms were cutting back due to the onset of the Depression, the Nessen Studio expanded and became a general distributor of lamps and furniture to the retail trade on a national basis. According to Alastair Duncan, "Von Nessen emerged as the premier Modernist lamp designer in the United States," creating table lamps of metal, glass, plastic, and other materials, which still look distinctly modern today. As examples of his chandeliers, pictures 1 and 2 show two designs he did for the Miller Lamp Company around 1930. They are typical of much of his work in their use of stark, rather angular shapes and concentric lines. Again to quote Alastair Duncan, "His lamps, especially, drew praise for their brazen modernity, both in form and in choice of bright metallic finishes. Geometric shades in frosted glass or parchment were housed on chromium-plated metal, brass, or brushed aluminum. Decorative accents were provided by Formica, Bakelite, or rubber discs or trim." This combination of unusual materials looks forward to his equally innovative use of Plascon handles on the pieces in the Stanhope pattern.

The Nessen Studio also specialized in small pieces of metal furniture, such as ash stands, side tables, combination table/bookcases, etc. From June 1930 to February 1931, advertisements appeared in House and Garden nearly every month, featuring many of these pieces. An article appeared in the February 1930 issue of House Beautiful devoted to those modern furniture designers whom the author, C. Adolph Glassgold, felt would be remembered in the future as the premier creators of furniture of their time. He included Walter Von Nessen, even though he felt he was limited because he worked "exclusively in metal, in which he is a master craftsman without equal in America."

So this indicates the stature of the man when he began his association with Heisey. Although I mentioned at the beginning of this article that the first pattern to be designed by Von Nessen was no. 1483 Stanhope in 1936, in fact his first work for the company was in late 1934. He was initially approached by Rod Irwin, Heisey's sales manager, in early September with a request to develop some designs for inclusion in a display of Modern Art and House Furnishings at the Metropolitan Museum. This exhibit, which opened in November, was limited to

continued on next page

WALTER VON NESSEN - continued

items which had never been shown to the public before, and with preparation time so short, Von Nessen modified a group of pieces from the existing lines.

This was a highly prestigious exhibit and included glassware from Libbey, Steuben, Fostoria and Bryce Brothers; however, in an article on the display which appeared in the winter 1934-35 issue of *Creative Design*, it was two of Walter Von Nessen's pieces which were most prominently featured. The shapes were very plain with the main design elements being "concentric lines, deeply incised and frosted creating a fanciful wavering pattern within the glass," according to the caption.⁴ These "Museum cuttings" apparently continued to be available from Heisey, though possibly only on a special order basis, for several years, since handwritten lists exist dated as late as 1942. Of all the pieces he was to create for Heisey, this group of vases and bowls are the most representative of the work Von Nessen did in most of the remainder of his career.

Heisey was not Von Nessen's only client during this period, of course, and the next significant development in his career seems to have had a direct impact on the creation of Stanhope. In 1930, he had begun to design serving pieces for the Chase Brass and Copper Company in Waterbury, Connecticut. These included coffee services and cocktail accessories in chromium plated copper with plastic handles. Being mass produced, these pieces were much more widely distributed than the limited editions produced by the Nessen Studio could be. Perhaps most fascinating to us is a covered punch bowl and cup (picture #3) which presumably was designed for Chase, though there appears to be no evidence that it was ever made. At any rate, the original drawing, dated September 1935, is clearly the prototype for the Stanhope pattern which was to come out less than a year later. The punch bowl was to be made of chrome and glass with plastic handles identical to those used in several of the pieces in the Stanhope pattern. (Curiously, the use of this handle on glassware was patented by Von Nessen and assigned to Heisey; if a similar patent exists for the use of these handles on metal items, I'm not aware of it.)

Stanhope was an artistic success, lauded as "so genuinely new and different that it takes the breath away."⁵ By February 1937, Heisey's ads were able to boast of the plaque that had been awarded the pattern in the Modern Plastic Competition, "more evidence of the fact that in creating the STANHOPE Pattern Mr. Von Nessen achieved new heights of design." But this combination of glassware with detachable plastic handles (in red, blue, black, yellow, ivory and green -- interchangeable to match a hostess' gown, table coverings, flower, or general room decor) did not really catch on with the public, and by 1941 it was discontinued.

Von Nessen's next pattern was the most successful: no. 1485 Saturn, which was made from 1937 to 1953, with some pieces remaining in the line until 1957 and a few (such as the chip and dip set) re-produced by Imperial. This was followed by no. 1488 Kohinoor (1937 to 1939, with the console set reissued from 1941-46). I don't know if any evidence exists in the archives of the HCA to substantiate this, but I suspect a number of the other patterns and individual pieces issued at around this time

could also have been created by Von Nessen.

In May 1937, Heisey's *Table Talk* announced that "Mr. Walter Von Nessen recently sailed for Europe where he will spend several months in intensive study in the various art centers on the continent. We are having him do this because we want the very newest and best ideas in glassware design."

The result of this trip may have been no. 1495 Fern, the last of the patterns known to have been created by Von Nessen. This line was made from late in 1937-1941, with some pieces continuing to be produced off and on in following years, including the candlestick. I find this the least typical of Von Nessen's designs, since it relies so heavily on ornamentation, albeit of a somewhat nontraditional nature.

I have not come across any further information about Von Nessen's career following his association with Heisey. It was not too long afterwards that he died, in 1943, while still in his early fifties. It is obvious that a brilliant career was cut short, but if the patterns he created for Heisey were, in fact, among his last achievements, they certainly provide a memorable finish to a life devoted to creativity.

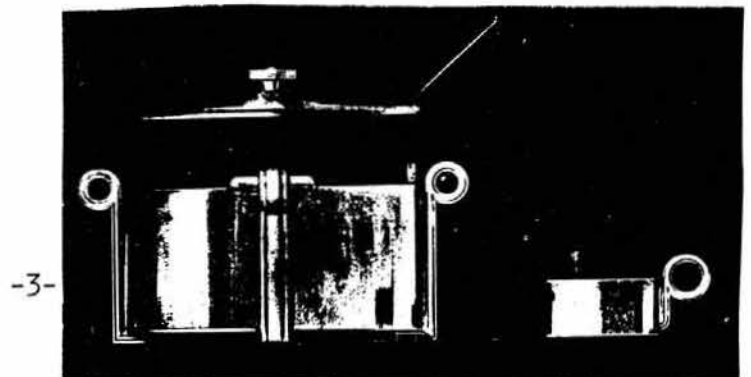
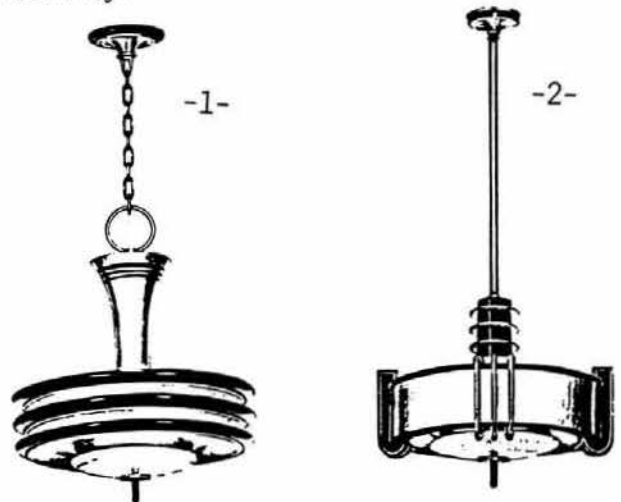

¹American Art Deco, p. 7.

²Karen Davies. *At Home in Manhattan: Modern Decorative Arts, 1925 to the Depression*, p. 24.

³*Creative Art* 2, June 1928.

⁴For more on this exhibit, see Joe Lokay's article and the letter by Rod Irwin reprinted in the *Heisey News*, March 1980, p. 7-9.

⁵*House Furnishing Dealer*, August 1936, p. 38.

NEILA'S NOTES

PATTERNS 1409 and 1410 -- CAMERA SHY!

By Neila Bredehoff, Archivist

For many years we have had the above two numbers in our list of Heisey numbers with the notation that 1409 was a plate and that 1410 was a cream soup and plate. Up until very recently we had not been able to find pictures of either of these. We decided that they were very camera shy and did not like to have their pictures taken - much like some people we know. Because of their location in the Heisey numbering system, we dated them from about 1931. Beyond that, we knew nothing about them except that they were included in some original Heisey price lists.

With the acquisition of some TABLE TALKS which had not been in our files, we finally are able to show these two patterns. I think it still would be difficult to identify the 1409 plate, but the edge is quite uneven, and if we had a plate "in person" to compare with the picture, we could probably be sure.

The 1410 cereal and plate is the most exciting to me since it supports a conclusion I had drawn some time ago but could not prove. Apparently the pattern was quickly made over into the 1415 Twentieth Century pattern or it was brought out simultaneously and the 1410 quickly abandoned in favor of Twentieth Century. Note that the 1410 bowl has the same basic outline and handles as Twentieth Century but lacks the distinctive foot and ribs. Many years ago I had seen a pitcher which matches 1410 but I have not seen another piece since. The pitcher in 1410 I had the privilege to see was in Crystal. I don't think either 1409 or 1410 were made for any length of time, so they are probably quite difficult to find. Does anyone have an example of either pattern?

Ed. Note: There is also a round plate in the 1406 pattern. There is a difference between them in that the square plate has "tear drops" going from the center of each Fleur de Lis. This plate is referred to as 1406 Fleur De Lis with Teardrop. The round plate is referred to as 1406½ Fleur de Lis. These names are not original but have been assigned.



New plates! And what beauties they are! In the background is the No. 1406 8-inch Square Plate and the one in front is the No. 1409 8-inch Plate. The other items are No. 3397 Sherbet with 448 etching and No. 1410 Cream Soup and Plate.

THE PHOTO REPRODUCED HERE IS TAKEN FROM THE JANUARY, 1932 TABLE TALK, A COPY OF WHICH WAS INCLUDED IN THE EXTENSIVE PAPER THAT OUR ARCHIVES ACQUIRED THROUGH THE GENEROSITY OF THE HEISEY FAMILY. OTHER PIECES PICTURED ARE #3397 GASCONY SHERBET WITH OLD COLONY ETCHING AND THE #1406 FLEUR DE LIS SQUARE PLATE.

FLEA MARKET ON THE SQUARE

NEWARK, OHIO

Saturday, June 10 & Sunday, June 11
Saturday, June 17 & Sunday, June 18

Dealer Space Available

For Information

Write: HCA Flea Market
P.O. Box 4367
Newark, Ohio 43055
Phone: 614-345-2932

GLASS AND POTTERY - SHOW AND SALE Over 40 Dealers

7th Annual Depression Era Glass and Pottery Show
St. Clair Fairgrounds (Air Conditioned Building)
Belleville, Illinois

Saturday, August 12 - 10 a.m. to 5 p.m.
Sunday, August 13 - 10 a.m. to 4 p.m.

SPECIAL GUESTS:

Gene Florence, Noted Author
Lee Garmon & Doris Frizzell, Co-Authors "Collecting Royal Haeger"

Special Displays: Heisey, Cambridge, Fostoria, Imperial, Fenton
Glass Repair (grinding) Available

Admission: \$1.25 (Good for both days) • Door Prizes
Sponsored by: Southern Illinois Diamond H Seekers

GLASS ANIMALS & FIGURINES

By Paul Kikeli

Paul Kikeli is a member in good standing of the HCA & NIGCS.

Man's universal affection for animals has been marvelously captured in imaginative form by the A. H. Heisey & Imperial Glass Companies. Each firm's figurines mimic life in fanciful manners. Whether it be a glorious Flying Mare, or a cute Piglet, a Minuet Girl, or a Parlor Pup, their collectibility is renowned. Heisey by Imperial and Imperial designed animals and figurines have sharply risen in value in the past couple of years. Imperial was forced to liquidate its assets in 1985 with production having come to a halt. The original Heisey moulds were purchased by the Heisey Collector's of America, Inc., located in Newark, Ohio. They had been owned by Imperial since 1958. These moulds are periodically used to benefit the HCA with small runs of animals or figurines by such companies as Viking or Fenton. However, as with original Heisey Crystal and Amber, Imperial's Crystal and various colored items have not been manufactured in several years.

Research is currently being conducted to determine production numbers of various Heisey by Imperial and Imperial animals and figurines. Thanks to the record keeping of former Imperial employees, antique dealers, the Heisey Collectors of America, Inc., and the National Imperial Glass Collectors Society members, this information will be made available in a forthcoming book. There is tremendous demand for a detailed background on Imperial glass. Recent enthusiasm in the marketplace is precipitating the collaboration of a comprehensive volume. Illustrations, price guide and photographs should be incorporated. If you are excited by the aforementioned project, you will enjoy the following data.

KNOWN COLORS OF VARIOUS ANIMALS & FIGURINES

Amber	Milk
Amberina	Nut Brown
Amethyst Carnival	Pink (+ Satin & Iridized)
Antique Blue	Red Slag
Black	Ruby
Caramel Slag	Salmon
Crystal	Sunshine Yellow (+ Satin & Iridized)
Horizon Blue (& Satin)	Ultra Blue (dark Blue)
Jade	Verde (Green)
Light Green: Satin	
Meadow Green: Iridized	

NOTE: Amethyst Carnival, Charcoal Satin, Crystal with various end-of-the-day color swirls were all considered experimental for feasibility study with certain moulds.



Imperial Glass



Arthur Lorich Imperial Glass 1981-84



Lenox Imperial Glass 1973-1981



New Imperial during Bankruptcy

IMPERIAL MARKS

PARTIAL LIST OF IMPERIAL ANIMALS & FIGURINES PRODUCED *

COLTS	Sunshine Yellow	sets-200
CYGNET **	Horizon Blue	100
FILLY, Head Forward	Crystal	1000
FISH BOOKEND	Verde	60
FLYING MARE ***	Amber	22
GAZELLE	Ultra Blue	300
MINUET GIRL	Rose Pink	426
PLUG HORSE	Antique Blue (HCA 1985)	450
RABBIT PAPERWEIGHT	Milk Glass	2700
ROOSTER	Amber	40
SCOTTY	Black	120
SMALL ELEPHANT	Nut Brown	175
SOW	Amber	200
STANDING COLT ****	Ultra Blue	1000
TIGER PAPERWEIGHT	Crystal	120

* Note: Amounts represent first quality items, not "seconds". We have no way to verify these #'s.

Collectors may better assess the potential value of their individual items based on available production quantities. During the very last days of pouring at Imperial, desperation for survival had heretofore unmoulded Heisey animal related pieces being recreated in various colors. These glassworks are extremely collectible due to their rarity. One recently discovered example is an Amber Doe Head which commanded a serious price at auction. Higher demands for collectible glass are bringing these unusual, non-production, generally unknown, items up for sale.

The National Heisey Glass Collectors Society elected the theme of "Heisey by Imperial" for their 1989 Annual Convention seminar this upcoming June. Undoubtedly, there will be many unusually colored and low production animals and figurines (not for sale) on display. The auction should be exciting, with the show yielding a multitude of collectible pieces for sale. This will be an exceptional event the serious glass animal collector will not want to miss.

How fortunate we Ohioans are that the Buckeye State has an abundance of collectible glass activity. Despite the amount of high quality glass manufacturers in this part of the country, Imperial and Heisey will always continue to shine brightly amongst them! Though in very good company, both firm's undeniably beautiful and unique creations have them setting many artistic standards.

The National Imperial Glass Collectors Society and Heisey Club of America have both contributed information used in the article. The author of the article is grateful for the periodic use of the Heisey Museum library and the gracious assistance of the museum staff.

** Light blue cygnets were made for HCA in a limited edition of 1040, 345 Satin and 1040 plain.

*** Even though Imperial sources say there were 22 firsts made, they sold far more than that.

**** All three colts were made in Ultra Blue for Dan Fortney a good many years ago. He advertised 1000 standing colts and 1500 each of kicking and rearing.

Editors Note: This article is reprinted from the April issue of the Imperial Glass Collectors publication, The Glasszette, with the permission of the author and the club.



Used on some Heisey by Imperial in early years and on the Asiatic Pheasant and on the Gazelle in 1983-84.

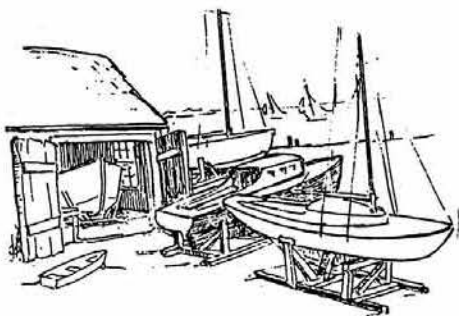

diamonds are forever

by Janet Caswell

It is difficult to ascertain just when the Yachting Center was permanently settled by the white man. Little by little the white visitors from surrounding colonies encroached upon the Indian encampments and stayed around Massabequish to fish and hunt. They called it their town. In 1629 Francis Higginson wrote, "here is plenty Marble stone --- our plantation is from hence called Marble Harbor". It was the independent trader, the dissenter, the unwanted, and the rugged fisherman who put down the roots of this plantation. By 1633 the name had been changed to "Marblehead" taking the entire peninsula, not just the harbor. The center of activity was not at the Great Harbor, but at Little Harbor, a snug island protected cove where the shallops rode safely at anchor and the fish was dried on the nearby ledges and rocky inclines. In 1635 the General Court had named Marblehead a separate plantation from our now adjacent town, Salem. For its first twenty years Marblehead belonged to Salem in a legal and territorial sense, but there it ended. These two plantations were as diverse a pair of settlements as could ever have shared a common boundary.

Plantation is also the name of a Heisey pattern, produced from 1950 to 1956 in Crystal. "The Farmer" from the Bay State (ma) had, on this particular day, worked in the fields all morning and decided to take a ride to the "big city". Upon arriving at a "real store", or rather Antique Shoppe, he proceeded to do a little browsing and much to his great delight, came across a real wealth of Heisey. One of the items he brought home with him was a pair of #1567 Plantation 3-lite candelabra with bobeches and "A" prisms. The #1519 Waverly 5" chocolate and cover with cresting wave finial and #507 Orchid etch, along with the Waverly 9" round 4-compartment relish, also Orchid etch, were eagerly placed in his truck and carried back to the homestead.

The Gator Guy and Gal from the Sunshine State (Fla) were fortunate enough to become the self-satisfied owners of a #1205 Fancy Loop medium size cracker jar (without the lid, unfortunately, but that's the way in which many are found), beautiful nevertheless!

Let me tell you what that sly but "Friendly Fox" from the Evergreen State (wa) tucked away in their "Lair": #1184 Yeoman two-handled bonbon with handles in Moongleam; also in Yeoman, two Moongleam ash trays (one perfect and the other has a fracture). Lastly was found eight (8) 7" #1225 Flamingo plates, these were a virtual steal.

"The South Jersey Troops" report the #1401 Empress Sahara individual cream and sugar while "AZ Heisey-holic" from the Grand Canyon State was in seventh heaven when she returned on the second day of a show to see if anything she had passed by the day before was still waiting for her; lucky day - she was able to purchase the following "jewels": #411 Rib and Panel sugar dispenser with a silver top in Crystal; #1405 Ipswich 8" square plates in Sahara (six of them); one Ipswich ½ lb candy jar in Crystal. Those plates must be elegant, to say the very least!

It's time I let you all know what the "Two Guys" from Connecticut are up to. Quite a bit of good, let me tell you: #4044 New Era Crystal clarinet (two of them): #1229 Octagon DO jelly in Sahara; #1503 Crystolite one-handled jelly with spiderweb bottom (very interesting piece); #352 Flat Panel Flamingo oil and vinegar.

"Vell here ve are reporting from Wisconsin Woods". It's Ole and Minnie again vinting to tell you about some Orchid etch they discovered: eight (8) 7" #1519 Waverly plates and a pair of #142 Cascade candlesticks.

"The Empire State Gal" wants to inform me of an unmarked Zodiac compote - cup shaped bowl. She was a bit puzzled about this piece wondering if it might be an Imperial item, but the one in the book has a different shape. In any case she said it was a fine piece of glass and the first in that pattern she had ever seen. So, purchase it she did. Also found was the #451 violet vase.*

"The Canadian Goose" reports the #1252 Twist individual bonbon in Marigold with gold trim that she retrieved and carried home. But, there was one that got away; an Emerald Winged Scroll jug (priced very dear) was seen at a show and was greatly admired. After walking around thinking about "do I want it for that price or not", she went back to the dealer. An hour had passed and the Winged Scroll jug was gone. I'm sure we have all done the same thing ourselves, perhaps even too many times. I know I have.

"Mountain Grandma" it is real good to hear from you again. The #1184 Yeoman cream DO in Moongleam was found along with the #479 Petal footed hotel cream in Moongleam.

"One Preacher and his Missus" report: one King Arthur wine with Moongleam foot & stem along with one King Arthur cordial, all Crystal. It was very nice meeting you both in March at the Auction; it is always a thrill to meet face to face the friends who write to me over the years.

Speaking of that, there are a lot of Heisey friends that I haven't heard from in "many a moon". Please drop me a line or two with your finds. My supply is getting quite low and I desperately need all your input. Besides, I really enjoy all your letters; it makes me a little less lonely to know so many of you are thinking of me.

Convention is about to begin and I hope to meet all my good friends again this year. Donald and I will be at the Display; please stop by and talk to us. I do so enjoy seeing you all and discussing our common interest.

* Jan says that the color is Alexandrite. This is extremely doubtful. The time and the color do not go together. It is probably sun purpled. Does it turn blue under fluorescent light?

CLUB NOTES

THE ROCHESTER AREA HCC

By George Reynolds

Our April meeting was held on the 16th at the home of Lois and Marvin Jacob. It was another beautiful day and the daffodils were just starting to show their faces. Knowing Lois, we're surprised that they weren't blue. Since Marvin is running for an HCA Directorship, his electioneering signs were all over the house. I thought this was illegal; well anyhow, he has our vote, great guy.

The meeting was called to order by our Prez, Bruce Schwendy. Our primary function for this meeting was to get the upcoming Convention display organized; this was finally completed. Sharon Orienter, our talented artist, picked the subjects and did the future arrangements in her mind. Most of the club will contribute one or more pieces of glass and other items for the display. Be sure to stop and see it, with Sharon setting it up, it will be exceptional. Sharon gave a Heisey presentation at the last local Depression Glass Club meeting. Needless to say, she did a wonderful job and is a fantastic ambassador for Heisey Glass. For those of you who do not know, she has designed the last two Convention posters as well. Really a very lovely talented person. I don't care if her husband (Frank) is jealous or not, besides I'm too old.

Arlene and I were at the March HCA auction and what an auction it was. We were all amazed at the prices but very happy to see HCA do so well. Sam's auction house is great now that the remodeling is completed. The glass is displayed in a much better fashion than previously and very available to inspect. We can't say enough about the committee that did all the work setting this auction up. After all the work unpacking, cataloging, etc., Bob Ryan still had enough energy left to help on the floor during the sale. Thanks should go to Sam too, he could have been using that lovely day to sell for his own business. After all that's why he is in business; thank you from us all, Sam.

The boss and I were lucky to find a perfect pair of Alexandrite #300 two-lite candelabra; they are complete with only the prisms Crystal. No, they are not for sale.

Back at the home front - the shows are coming fast and furious in this area. This weekend alone we attended three shows and ended up with one three-handled Empress sugar and a nice Crystolite divided covered candy. Harold Ames, a member of HCA and a great guy, had some beautiful Arch Cobalt tumblers at a show we attended this morning. I had to tell him they were Cobalt, not Gold. He also had another exceptional find, a cup and saucer from the Graf Zeppelin in mint condition. Now these may turn out to be Gold after all. For those of you not around in the 1930's, the Graf Zeppelin exploded while landing in New Jersey on a trip from Germany. This was shortly before we entered the war and quite a momentous thing at the time. Just driving to Jersey is dangerous enough without trying to land a Zeppelin there.

Just one more note and I'll end this. Congratulations have to go to Louise and her staff for getting out both a newsletter and an auction list in February. For those of you who have never tried

this, it is impossible to explain how much work it is while still trying to run a Museum as well. Great going, Louise, and thanks.

The quote for the month. "The man who has nothing to boast of but his illustrious ancestors is like a potato -- the only good belonging to him is underground". Sir T.O.

THE BAY STATE HCC

By George Gleason

The Bay State Heisey Collectors Club held its regular monthly meeting on April 11, 1989, with our new President, Stephen Pescatore, presiding.

The program for the evening was planning for the convention display in Newark this year. We have come up with a pretty good idea we think - come and see us in Newark.

We put the finishing touches on our own "all-glass" show. By the time this is printed the show will be over. I hope everyone had a good show and the finds were equally as good. By the way Gary Olson and his committees did a superb job. Thanks Gary for another good show.

Show and Tell conducted by David Steer was something out of this world.

Herewith some items brought:

- Dolly Madison rose plate
- Kohinoor ash tray
- Heisey ads
- 1205 cracker jar
- 1295 goblets in Custard, pr.
- Locket on Chain sugar & creamer and a nappy, no less, a goodie

Refreshments for the evening were provided by Jean Bumbaca. She really outdid herself. Everyone really enjoyed the buffet of food she put out.

We were saddened to hear of Peg LaRosa's death. Our prayers go out to her and our sympathy to her husband, Pat.

See you next month.

Ed. Note: George Gleason called to tell us that Jean Siek's date of death was printed as 2089 instead of 1989. That was a terrible error and we apologize to her husband, Richard, The Bay State HCC and to George.

George also said he has been treasurer of the Bay State Club four years, not five. Sorry George - L.R.

DAYTON AREA HCC

by Karen Clark

The April 18th meeting of the Dayton area study club was attended by 16 members. The meeting was held at the Huber Heights library.

Our theme for the display at the convention was discussed. It was decided not to have a display this year but instead devote our time to the "Silent Auction". We have 14 members who will be helping with this on Saturday evening during the convention. Our Show and Tell "prize winner" for the evening was a Lattice Band nappy brought by Jane and Ira Brooks. Everyone agreed that it was a super find!

A big thank you to Bob Ryan, outgoing Club President - continued on page 10

ident, and Clarke West, outgoing Secretary - Treasurer for their faithful service to the club for many years.

Our "silent auction" of Heisey, Imperial and "goodies to eat" added \$81 to our club treasury. Our club holds monthly meetings (3rd Tuesday) at the library - 6:30 p.m. Anyone wishing further information may contact us through HCA in Newark. New members are always welcome!

Carl Vorpe, President, and Karen Clark, Secretary - Treasurer, were elected at the March meeting to serve as officers for one year.

SOUTHEASTERN MASSACHUSETTS HCC

Our mini-auction in March was a tremendous success. Auctioneers Bill Thran and Donald Macomber conducted a lively session. Members "put their right hands up, then put their right hands down, put their right hands up again and shook their cards about". There was no hokey-pokey to the auctioneer's shout that night at the Banck's studio in Rockland, Massachusetts. Bids flew fast and furious! Members were quick to capture their prizes.

The following were some of the items:

- Medium Flat Panel mug (shaving mug)
- Punty & Diamond Band punch cup
- Cobel cocktail shaker
- Picture of old Heisey Glass Factory
- Waverly goblet
- Two Twist goblets which were iridized
- Two Peerless goblets
- Two Colonial dessert plates
- Octagon 2-handled jelly in Moongleam
- Seven Victorian sherbets
- Wide Flat Panel mustard w/lid
- Heisey paperweight
- Warwick individual candle holder in Crystal
- New Era 2-lite candelabra
- Ridgeleigh floral bowl in Sahara

Since most of us could not attend the Heisey Auction in Ohio, we hoped to raise some money and excitement for the National Convention in our own little way.

Our club wishes to thank Janet Caswell and her son, Donald Macomber, for transporting our frosty Crystal via sleigh to the convention. "Christmas in June" never had better elves! Janet is doing a wonderful job as program chairperson this year. In fact, she presented a superb program on the "Black Light". Some special "black light" pointers which she shared with us included the following:

- Use the flourescent tube type
- The portable battery type is not as efficient
- Darken the room
- Hold the glass close to the light

Future programs will include the Ridgeleigh pattern by Richard Martell, and in April, we are expecting a surprise visit by Norman and Janice Thran from Ohio. Again, the motto of our club is education, not "hokey-pokey", and we are proud of our members.

In reference to Louise Ream's article from the "Desk of the Editor" of Heisey News, May, 1989, in which she mentions the concern of some members who wonder who will carry on the love of Heisey, we would like to confirm that our club has "hooked" several new members. Membership chairperson, Maria Martell, will attest to the raging love affair with

by Mary Neckes

WANT TO START A STUDY CLUB?

IT WOULD INCLUDE ST. LOUIS COUNTY AND CITY, FRANKLIN, JEFFERSON AND ST. CHARLES COUNTIES - AT THE VERY LEAST.

ANYONE INTERESTED IN A STUDY CLUB IN THESE

AREAS PLEASE CONTACT: NORMA AND GEORGE SCHWEIGHOEFER

PH: 256-8975

484 HILLBROOK BALLWIN, MO 63011



DEAR SANTA

Everything is ready! Candles have been set, candy jars filled, the tree trimmed. Jay Martin and committee even have cookies and milk set in the lounge for your refreshment. If your usual mode of transportation should also require refreshment, not to worry - the lawns and gardens of Newark and Granville are very lush this time of year. And just wait until you hit the show with your list for those hard-to-please stocking marauders. You will be dazzled by the sheer wonderment and beauty of "Santa's Workshop". Jim Reynolds, Frank Harper and committee have recruited show dealers whose wares are unequalled and likely not to be found anywhere else. Just between you and me, I've heard whispered rumors that some items on display might be the elusive and never before seen Tangerine flying mare, a favor vase in gold opalescent, a hurricane globe with the Chintz etch and a Fandango pitcher in Emerald. Can you believe it?! Put those in your bag of goodies.

If you've not made note of it yet, don't forget the reception for "Santa's Elves" (former Heisey employees) to be held at the Buckingham House (two doors from HCA museum) on Saturday. This friendly group will delight and amaze you with their fond remembrances of the glory days of Heisey.

So "Tally Ho-Ho-Ho" Santa! Come on up - don't let this be a "Blue Christmas" -- lift our "Christmas Spirits" with the "Nutcracker Sweet". And, on that "Christmas Wish List", Santa, don't forget mine -- an eighteen inch Alexandrite ball vase with the Mermaid etch.



Wishing you a "Cool Yule!"

Amy Jo Jones

Convention Co-Chairman

Can we excuse Amy Jo for "dreaming" a little? She has been very busy lately and visions of sugar plums must be dancing in her head. She's done a great job as Convention Co-Chair! L.R.

HISTORY OF GLASS - FROM OUR ARCHIVES

Material for this article contributed by Thomas S. Buechner, Director, The Corning Museum of Glass; and Mr. James V. Mathews, Assistant to the Director Corning Glass Center.

Glass is one of the basic materials which man has employed since the beginning of recorded time. We explore through it, drink out of it, and control heat and light with it; it is a substance of great versatility and unlimited possibilities.

In the beginning, glass was made by nature and not by man. When fire came out of the earth during volcanic eruptions, it melted whatever sand was lying about into a homogeneous mass called "obsidian". Structurally, obsidian is a true glass, not crystalline like certain quartz minerals and rock crystal. Prehistoric man shaped this natural glass into primitive tools and weapons by slowly chipping away the edges until they were razor sharp. Some tribes of American Indians, including the Incas in South America, made arrowheads and amulets out of obsidian by this same simple process.

The first man-made glass did not look at all like the substance we call glass today. About 2500 years before the birth of Christ, the Egyptians, and perhaps the Sumerians had learned how to make a viscous glaze with which to decorate their pottery. This glaze was a kind of glass, made out of silica (or sand) and certain powdered metallic substance which were moistened and painted into the clay pot. When the piece was fired in a simple oven, the sand and other materials became soft and stuck together. This produced a harder, slightly shiny finish on the pot. Glass of this kind is called frit because it has not been completely melted into a homogeneous mass.

Solid glass vessels were made at least 3500 years ago in Egypt and possibly Assyria. The process may have been discovered during the improper firing of a glazed bead; if the ceramic core disintegrated, a little cup of frit glass would remain. This is the essence of a technique which was used for over a thousand years. A core was made of sand, held together by some gummy substance; this core was then slipped into a semi-fluid pot of hot glass and rolled until completely covered with glass. When the glass was cool, the sand core was scraped out. Naturally, most of the objects made this way were small. Perfume and oil bottles were made for export to other countries as well as for the Egyptian nobility.

A century or two before the birth of Christ, glass blowing was discovered. The first blown pieces may have been made by making a tube of glass, reheating and sealing one end and then inflating it by blowing in the cool end, just as much of our laboratory apparatus is made today. One of the first great names in the history of glass making is "Ennion", a Sidonian who lived between 100 B.C. and 100 A.D. He blew colored glasses, often an ivory white, into beautifully carved molds. Many of his most important surviving work bears his name and the inscription "Buyer Remember, I Ennion, made this".

During the first three centuries of our era, glass became a household item. Under the civilizing influence of Roman rule, a glass industry was developed which made all kinds of common table glass,

containers, lamps, fernery urns, and so many other things that the substance was as well known then as it is today.

Although Roman glass is crude compared to our own, it was a great improvement over the frit of the Egyptians. You could see through it, it could be as plastically manipulated as our own glass can, and it was inexpensive enough so that every one could have it. In addition to the ordinary ware, Roman glass makers made beautiful bowls out of colored sections of glass; they engraved gold leaf between two layers of glass and they carved magnificent glass cameos, the most famous surviving example of which is the Portland Vase. As craftsmen, their work is unsurpassed.

As the great Roman Empire began to disintegrate, in the late 5th century A.D., the center of the glass industry moved east into Persia. The ingenuity of the Persians, and later the Saracens was focused primarily on decoration and not on the quality of the glass itself. Magnificent deep cut pieces, wonderful vessels in the form of animals and, the greatest achievement of all, exquisitely enameled bottles and lamps have survived as proof of the superb craftsmanship extant in the ancient Near East from 800 - 1300 A.D.

Towards the end of the middle ages, as Venice became a great seaport and the center of world trade, glassmaking moved back to the Italian peninsula. Some of the simple Roman styles and techniques had survived in small local glass houses, particularly in the vicinity of Altare and, further north, under the rule of the Kings of Merovis. This original industry plus the achievements of the Near Easterners combined to produce some of the most exotic and delicate glass the world has ever seen.

The art of glassmaking, in medieval and renaissance Italy was a secret art as well as a fire hazard. For these reasons, the island of Murano, near Venice was reserved for the glass industry and is still being used for that purpose today. Naturally, the Venetian merchants were extremely anxious to protect their lucrative monopoly and therefore the death penalty was inflicted on anyone who tried to escape.

In the 15th and 16th centuries, the simple forest glass houses of Holland and Germany began to do a thriving business. In addition to the little green printed cups and later the hollow trunked roemers, the northern glassmakers produced all sorts of ware in the elaborate Venetian manner. One of the most successful combinations of these two distinctly different glassmaking concepts is the flute with its delicate Venetian stem and Dutch-German conical bowl.

The English, particularly Giacomo Verzelini, who had come from Venice, began to produce glass in a rather crude Venetian-like way in the 16th century. Less than 100 years later, George Ravenscroft had made the first successful lead glass, a glass so beautifully clear and brilliantly reflective that it deserves the metaphoric adjective "crystal". Blanks (undecorated vessels) of this new glass were sent to Holland and Germany to be decorated by the masters of copperwheel and diamond stipple engraving. During the Jacobean intrigues a vast number of drinking vessels were produced bearing engraved heraldic symbols representing the young pretender and other members of the existing Royal family.

In 1608 the London Company installed America's
continued on page 12

first industry; a handful of imported glass blowers were sent to the colony of Jamestown. Although records of the company indicate that glass was made, no example survives which can be definitely attributed to this first venture. Isolation, Indians, and unbearable living conditions were responsible for the collapse of this first attempt at glassmaking.

New Amsterdam apparently supported two glass houses in the 17th century but Caspar Wistar, in Salem, New Jersey, was the first successful glassmaker about whom we have any accurate information. A commercial producer of bottles and window glass, Wistar founded the South Jersey tradition. The workers in his factory made off-hand pieces on their own time from the remainder of the day's glass. They were for their own personal use; today they are the collector's items.

Deming Jarves is perhaps the first to deserve the title "industrialist", in every sense of the word. In addition to being the first to obtain patents on pressed glass machinery, he was the agent for the New England Glass Company, founder of the Cape Cod Glass Company, the Mt. Washington Glass Works, and in 1820 the famous Boston and Sandwich Glass Company.

From the early application of industrial techniques glassmaking in America has expanded to the point where it now employs 138,000 people and does a yearly business of \$1,310,000,000.

Scientific research in the field of glass manufacturing had led to the development of not only better and more types of glass but it has also prompted the creation of a machine industry to facilitate the production of these items that were hitherto unknown.

With the exception of some forms of art and table glassware, and intricate scientific laboratory apparatus, nearly all industrial and commercial glassware is now produced on semi or fully automatic machinery.

The first glass envelopes for the incandescent light bulbs were hand formed and blown, a laborious time consuming process. While today there are machines which can produce from a continuous ribbon of molten glass a million bulbs in twenty-four hours.

The successful casting of the 200" mirror disc for the Hale telescope at the Palomar Mountain Observatory in 1934 by Corning Glass Works is one of the outstanding accomplishments of glass technology.

The rapid progress of the glass industry is due to several factors. Several new methods for making hotter fires by the proper combination of fuels; more efficient furnaces or "tanks" have been developed. Where wood and charcoal were once used to melt the dry raw materials of glass now oil, propane and primarily natural gas produce the required heat to liquify the dry components into a molten metal with temperatures that may reach 2800 degrees F. New types of ceramic block of which these tanks are built are constantly being tried and improved. Applied metallurgy has provided the answers where metal must be used in molds, and systems have been engineered to make glass manufacture, in many cases, a fully automatic process.

Such a multitude of glass products exist today as a result of this evolution that their listing would be impossible. It must be remembered that the types of glass from these items are made, differ al-

so to extreme degrees. Some glasses are almost as heavy as iron or as light as cork, as strong as steel or as fragile as an eggshell, as hard as precious stones or as soft as cotton; while others conduct or stop the flow of electricity, transmit the invisible rays of the spectrum such as x-rays while stopping the visible rays. Conservative estimates indicate that over 50,000 different formulae have been created for the production of commercial and industrial glass as well as table glass. As to the number of separate and distinct products which have been made of glass the total, which would include mass produced items as well as those made in research laboratories, is estimated at over 37,000.

We are living in an age when glass, either directly or indirectly, influences our life almost constantly. In many ways this influence is not recognized but could be only appreciated if it ceased to exist. A typical example would be development of a glass godet wheel which is used in the manufacture of synthetic fibers, primarily rayon. Because of their hardness and resistance to wear these glass wheels on which the fiber is wound have increased the availability of the end of product and reduced its cost to a point where it can be used and enjoyed by all of us. This, indeed, is a relatively unknown use of glass when compared to the rapidly expanding television industry which depends so heavily on glass products.

The versatility of glass is being steadily increased. Window glass which was quite fragile can now be made almost unbreakable and experimental automobile bodies are being produced -- bodies which depend on fibers spun from glass for their residual strength. There is no phase of life which is not dependent on glass for some portion of its existence.

The future for glass seems to be unlimited. The tremendous advance of the past twenty years in the marketing of new glass products would indicate that glass in all its forms will be even more closely integrated with human achievement and comfort than it is today. The new methods already developed for producing plate glass, glass block, glass fiber, colored glass and strong tempered glass serve to intensify the research programs of American glass industries. This trend has pushed the glass producing companies, as a group, into the billion dollar classification among the most important industries in our land.

There is every reason to believe that we are on the threshold of even greater development in glass products and their uses which will contribute materially to our comfort and well being. We are living in the age of glass.

Ed. Note: The date of this article is unknown. Many articles about making glass have been written and several have appeared in Heisey News. This one having been written by such prestigious people is apt to be more accurate than most of the others.

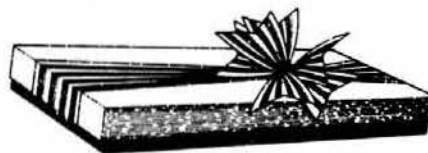

Treasurers Report for 1988

CASH BALANCE DECEMBER 31, 1987	\$ 4,112.03
CASH RECEIVED:	
Initiation Fees	\$ 825.00
Charter Fees	50.00
Membership Fees	40,639.00
Newsletter Ads	5,882.24
Cash Donations	1,624.03
Sales, Taxable & Non Taxable	108,058.64
Sales Tax Collected	2,781.51
Shipping & Handling	3,629.44
Museum Admissions	3,081.00
Insurance Income (Blue Cross)	1,021.60
Insurance (Warehouse)	1,950.84
Royalty Color Book	2,162.10
Interest Income (Checking Account)	583.63
Refunded Bank Charges	1,009.80
Sales refunds	338.10
Vending machine	53.00
Donation - Endowment Fund	4,660.00
Donation - Acquisitions	5,608.00
Donation - Payment on Loan	1,000.00
Donation - Research & Archives	375.00
Donation - Outside Museum Restoration	700.00
1988 Auction	10,999.12
1988 200 Dinner	6,118.97
1988 Convention & Flea Market	29,408.10
1988 Souvenir Dinner	8,556.90
1988 Picnic in the Park	283.26
1988 Christmas Dinner	1,317.75
TOTAL CASH RECEIVED	\$242,717.03

CASH PAID OUT:

*Club Expense	\$ 32,079.08
Club Utilities	4,540.49
**Museum Expenses	18,290.41
Museum Utilities	4,852.70
Newsletter Printing & Postage	18,228.59
Merchandise Bought for resale	28,453.87
Cost of Sales	3,794.99
Sales Tax Paid	2,758.20
General Advertising	3,057.13
Salaries	40,823.61
Cost of Salaries	12,972.40
Bank Charges	3,104.51
Sales refunds	338.10
Warehouse Expenses	2,752.55
Archives & Research	1,470.48
Acquisitions	5,704.00
Paid to Endowment Fund	4,660.00
Membership refunds	118.50
Computer Expense	910.00
Interest paid on Loan	4,242.18
Payments on Loan	18,000.00
1988 Auction Expenses	734.50
1988 Convention & Flea Market Expenses	22,596.62
1988 Souvenir Dinner Expenses	4,220.41
1988 Picnic In The Park Expenses	276.24
1988 Christmas Dinner Expenses	1,240.88
1989 Convention & Flea Market Expenses	205.00
TOTAL CASH PAID OUT	\$240,425.44

CASH BALANCE DECEMBER 31, 1988

\$ 6,403.62

1989 Budget

INCOME	
INITIATION FEES	\$ 875
MEMBERSHIP FEES	42,000
NEWSLETTER ADVERTISING	6,000
SALES, TAXABLE & NON TAXABLE	125,000
MUSEUM ADMISSIONS	3,500
CASH DONATIONS	15,000
BENEFIT AUCTION (net)	11,500
CONVENTION & FLEA MARKET (net)	5,500
SOUVENIR DINNER	5,000
APRIL 200 DINNER	5,500
ROYALTY FROM COLOR BOOK	2,000
NOTE	16,500
TOTAL	\$238,375
EXPENDITURES	
NEWSLETTER PRINTING & POSTAGE	\$ 20,000
CLUB EXPENSES	28,000
MUSEUM EXPENSES	15,000
UTILITIES - CLUB & MUSEUM	11,000
PURCHASES FOR RESALE (Oscar, etc.)	60,000
SALARIES & RELATED COSTS	65,000
PAYMENTS ON NOTE	15,000
INTEREST ON NOTE	3,500
ACQUISITIONS	3,000
RESEARCH & ARCHIVES	2,000
EDUCATION PROGRAM	375
GENERAL ADVERTISING	3,000
WAREHOUSE EXPENSES	2,500
COMPUTER & RELATED EXPENSE	10,000
TOTAL	\$238,375

BUDGET AND FINANCE COMMITTEE: DICK MARSH,
LOREN YEAKLEY, ROBERT RAREY EX OFFICIO,
WANDA LYBARGER ADVISOR.

MARY MC WILLIAMS, CHAIRMAN AND TREASURER
PASSED BY THE BOARD MARCH 11, 1989

Classified Ads

FOR SALE: #310 Ring Band berry bowl and 6 small nappies in Ivorina Verde. Marked with large H. All pieces mint condition. Rose decor. Asking \$425. Marilyn Barker - 813-275-7872 after 4 p.m.

WANTED: #517 Blown glass water set. One quart jug with tumbler in top. Barbara Casson, 3611 Benhill, Cincinnati, Ohio 45247.

WANTED: #423 Diamond Band 1200 Cut Block punch cups. W. B. Gibbs, 1303 N. Sellars Mill, Burlington, NC 27217. PH: 919-226-7669.

WANTED: Imperial Animals and Figurines. Collector, P.O. Box 1115, Newark, OH 43055.

FOR SALE: Heisey, Imperial (out of Heisey moulds), and Verlys Apple Tree Auction Center 1987-1988 Comparison Price Guide. Price \$13 prepaid. Mail to: B Whaley, 300 International Dr., Pataskala, Ohio 43062.

WANTED: 1503 Crystolite Rosette candle holders in Ruby (by Imperial). Terry Cranston, 7789 Pontiac Lane Road, Pontiac, Michigan 48054.

SANTA SAYS...

SEE ME AT THE HEISEY CONVENTION
JUNE 15 - 18!



GRANVILLE, OHIO'S
17TH. ANNUAL ANTIQUE SHOW & FLEA MARKET
GRANVILLE HIGH SCHOOL - RT. 661 N.

<u>INSIDE</u>	<u>OUTSIDE</u>
JUNE 14 4 - 9	JUNE 15 DAWN - DUSK
JUNE 15 9 - 8	JUNE 16 DAWN - DUSK
JUNE 16 9 - 8	JUNE 17 DAWN - DUSK
JUNE 17 10 - 4	

KENNETH FISCHER will be repairing glassware. Over 100 dealers with furniture, glassware, pottery, books, crafts, primitives and lots of miscellaneous. (Thousands of pieces of Heisey) Vogel's books on Heisey will be for sale.

FREE ADMISSION FOOD PLENTY OF PARKING

No reservations needed for outside space

FOR INFORMATION: MRS. BETTY MORRISON
127 E. ELM STREET
GRANVILLE, OHIO 43023

TELEPHONE: 614-587-1062 or
366-3298

Sponsors: Granville Athletic Boosters

<u>ASSETS</u>	December 31, 1988	<u>LIABILITIES AND FUND BALANCES</u>	
<u>CURRENT ASSETS</u>		<u>CURRENT LIABILITIES</u>	
Cash	\$ 6,952	Accounts payable	\$ 3,450
Accounts receivable	612	Accrued sales tax payable	142
Inventories - merchandise	109,010	Accrued withholdings payable	284
Prepayments	<u>3,845</u>	Accrued expenses payable	1,626
Total Current Assets	\$ 120,419	Notes payable - bank	<u>12,000</u>
<u>INVESTMENTS</u>		Total Current Liabilities	\$ 17,502
Corporate stock (market value \$95,126)	108,807	<u>LONG-TERM LIABILITIES</u>	
<u>NON-DEPRECIABLE ASSETS</u>		Notes payable - bank	35,000
Heisey glass - donated	164,242	Less: due within one year	<u>12,000</u>
Heisey glass - purchased	114,984	Total Long-Term Liabilities	<u>23,000</u>
Research and archives	<u>5,483</u>	Total Liabilities	40,502
Total Non-Depreciable Assets	284,709	<u>FUND BALANCES</u>	
<u>PROPERTY ASSETS</u>		General fund	313,569
Land	17,600	Investment fund	108,807
Museum building	131,571	Heisey glass - donated fund	164,242
Office building	84,123	Heisey glass - purchased fund	114,985
Warehouse building	22,400	Research and archives fund	5,483
Furnishings and office equipment	29,446	Property assets fund	217,400
Tables	13,638	Endowment fund - restricted	<u>30,351</u>
Motor vehicles - trailer	1,400	Total Fund Balances	<u>954,837</u>
Moulds	<u>233,397</u>	<u>TOTAL LIABILITIES AND FUND BALANCES</u>	<u>\$ 995,339</u>
Total Property Assets	533,575		
Less: accumulated depreciation	<u>82,778</u>		
Net Property Assets	450,797		
<u>OTHER ASSETS</u>			
Deposits - workers compensation and other	256		
Restricted fund - endowment:			
Park National Bank - cash	210		
Park National Bank - cash/securities	29,602		
Klawans - securities (market value \$374)	<u>539</u>		
	<u>30,607</u>		
<u>TOTAL ASSETS</u>	<u>\$ 995,339</u>		

Auditors Report for 1988

NADINE PANKOW
 207 S. OAKWOOD
 WILLOW SPRINGS, IL 60480

PH: 312-839-5231
 UPS & INS EXTRA

MISCELLANEOUS HEISEY

Penquin decanter \$ 190.00
 4225 top for cocktail shaker 15.00
 4225 top for cocktail shaker w/strainer 35.00
 World candle 175.00
 Plume stopper for 1519 cruet 35.00
 2 peg bowl for candle 15.00

ANIMAL STEMS

Seahorse cocktails (3) ea 140.00
 Rooster stem cocktail (6) ea 45.00
 Goose stem sherry 160.00

ANIMALS

Clydesdale 375.00
 Gazelle 1800.00
 Goose, wings up (2) ea 80.00
 Goose, wings half (3) ea 70.00
 Giraffe, head back 150.00
 Pony, balking 175.00
 Rooster vase 75.00
 Scotty dog 125.00
 Sparky (plug) pink 35.00
 Sparky Crystal 95.00
 Sparrow 150.00
 Swan, solid (near mint) 475.00
 Tropical fish (as is) 150.00
 Filly, head forward 750.00

Ambassador Etch 8 oz tumblers (6) ea 12.50
 Crystolite cruet w/stopper 39.75
 3390 Carcassonne 2 oz ftd bar tumb, Alex-
 andrite (9) ea 100.00
 3390 Carcassonne 12 oz ice teas, Alex (5)ea 125.00

MOONGLO CUT

Cups & Saucers (8) set 29.75
 Saucers (4) ea 9.75
 Covered mustard 85.00

LARIAT

Champagnes (8) 14.50
 Cream & Sugar w/cutting 24.50
 473 Narrow Flute w/Rim 3½" nut dishes, Fla-
 mingo (12) 12.50
 Plantation shakers, 1 cloudy pr 24.75
 Renaissance Etch goblet 29.75
 4092 cocktails 3 oz w/Rosalie Et, (7) ea 16.75

ROSE ETCH

Plates, 8" (13) ea 20.00
 Ice Teas (10) ea 35.00
 Goblets (6) ea 39.50
 Champagnes (12) ea 30.00
 Cruet, ftd, handle crack 35.00
 Butterdish, covered 160.00
 Cream & Sugar 55.00
 Dolphin comport, oval, 7" 95.00
 Mayo, 2 pcs, ftd 65.00
 1464 Ice jug 575.00

TEA ROSE ETCH

134 Trident candle 30.00
 1184 Yeoman cream soups, Moongleam (2) ea 12.00
 1184 Yeoman goblet, Moongleam 10.00

ORCHID ETCH

Goblets (20) ea \$ 32.50
 Champagnes (30) ea 28.50
 Cocktails (5) ea 35.00
 Wine (25) ea 49.75
 Goblets, short stem (24) ea 29.00
 Sherbets, low (22) ea 22.75
 Gardenia bowl Waverly 13" 55.00
 Plate, flat, Waverly 13" 55.00
 Plates, 7½", (22) Waverly ea 18.00
 Plates, 8½", (5) Waverly ea 20.00
 Cups & Saucers (5) Queen Ann set 42.50
 Saucers (2) Waverly ea 6.00
 Condiment bottle, flat 250.00
 Ashtrays, square (3) ea 30.00
 Salt & Pepper shakers, very sl cloudy pr 55.00
 Vase, crimped, 7½", Lariat 95.00
 Butterdish, covered (2) ea 150.00
 Cream & Sugar (3) set 45.00
 Dinner bell 95.00
 4036 Decanter, oval sherry 250.00
 Candles, 3-lite pr 135.00
 Candle, single 2-lite 70.00
 Candle, 1-lite pr 40.00
 Plume stopper for cruet 35.00
 Queen Ann oval combo bowls (3) ea 45.00
 Queen Ann 5½" ftd mints (2) ea 32.50
 Queen Ann 6" ftd handled jelly (2) ea 32.50
 Queen Ann 6½" covered lemon dish 250.00
 Queen Ann cheese & cracker 125.00
 Waverly 7" ftd jelly (2) ea 40.00
 Waverly 11" 3-part celery/relish 45.00
 Waverly 12" celery/relish (2) ea 50.00
 Waverly crimp bowl, 10" (5) ea 75.00
 Waverly 7" dolphin ftd comport 75.00
 Waverly 6½" low ftd comport (2) ea 32.50
 Waverly 11" demi torte plate 75.00
 Waverly 14" flat sandwich plate 65.00
 Waverly 12" crimped floral bowl 60.00
 Waverly 14" rolled torte plate 52.50
 ALL MINT. RETURN PRIVILEGE WITH STICKER INTACT.

* UPS MINIMUM \$3.00. THANK YOU.

* * * * *
 * OAK GROVE ANTIQUES PH: 508-772-2538
 * 49 GROVE STREET AFTER 5 P.M.
 * AYER, MA 01432 P & I EXTRA

* 411 Rib & Panel (Tudor) Et 8 oz goblets*(4)\$ 65.00
 * 449 Thumbprint & Panel double candle-
 * sticks, etched pr 115.00
 * 465 Recessed Panel 8" basket* 115.00
 * 1472 Parallel Quarter 12" bowl*,King House
 * Etch 38.00
 * 1519 Waverly 13" Gardenia bowl, Orchid Et 65.00
 * 1540 Lariat tray for ind cream & sug, Moon-
 * glo cut 12.00
 * 5025 Tyrolean tall gob, Orchid Et (8) 255.00
 * 5025 Tyrolean low gob, Orchid Et (4) 110.00
 * 3333 Old Glory 3 oz wines* (5) 100.00



ROBERT H. DONOVAN
55 VINING COURT
ORMOND BEACH, FL 32074

PH: 904-677-1732
P & I EXTRA
* = MARKED

- 1560 Victorian Belle (bell), frosted, Crystal and Gold \$ 75.00
- 1489 Puritan vinegar & oil bottle* 28.00
- 1401 Empress 13" celery, Moongleam 42.00
- 1252 Twist single sticks*, Moongleam . . pr 55.00
- 1536 Military Cap ashtray 30.00
- 1497 Boat floral bowl, V-IV, pg 27, no. 4 . 28.00
- 4301 puff box & hair receiver*, etched . . 195.00

- 5086 cocktail, 3½ oz, Ivy etch (4) . . . ea 28.00
- 1401 Empress 9" DF vase, Grape etch . . . 28.00
- 3440 Portsmouth 9 oz goblet, D0, Flamingo, (3) ea 39.00
- 1445 Grape Cluster sticks, 2-lite . . . pr 195.00
- 1445 Grape floral bowl* 155.00
- 300 Peerless 4½ oz claret* 14.00

- 3390 Carcassone ftd water, Sahara, etched, (2) ea 18.00
- 341 Puritan punch cups* (5) ea 6.00
- 407 Coarse Rib 12" celery*, Amber 42.00
- 1252 Twist 4" nappy*, Flamingo (3) . . . ea 12.00
- 1170 Pleat & Panel mayonnaise* 18.00
- 1401 Empress cream & sugar*, DF, Sahara . pr 72.00

- 1519 Waverly cream & sugar*, 507 Orchid etch pr 68.00
- 1252 Twist 2-part relish*, Moongleam . . . 68.00
- 1252 Twist ice bucket*, Moongleam 108.00

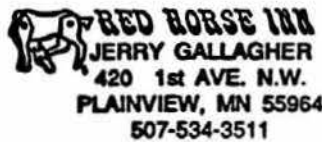

- 1931 Old Morgantown catalog reprint, postpaid 10.50
- 3404 Spanish 10 oz ftd tumbler, Cobalt . . 75.00
- 1404 Ipswich c/vase inserts, clear, . . pr \$125.00
- 1467 Ridgeleigh 6" diam. "square" (rounded corners) underplate liner for square marmalade - hard to find 48.00
- 1428 Warwick vase/cigarette, Cobalt 95.00
- 3390 Carcassone match holder, Cobalt . . . 90.00
- 305 Punt & Diamond Point paste pot, no brush 95.00
- 3411 Monte Cristo goblet, Olympiad Et (4) . 40.00
- 3411 Monte Cristo goblet, Waikiki cut (1) . 48.00

- 5040 Lariat ice tea (2) 24.00
- 141 Edna U-Shape candlesticks pr 265.00
- 1509 Queen Ann - 502 Crinoline Etch
 - (a) 8-cup/saucer 30.00
 - (b) 8-8" round plate 18.00
 - (c) 9-6" round plate/liner 16.00
 - (d) 7" oval comport 68.00
 - (e) cream & sugar, DF pr 60.00
- 5010 Symphone - 502 Crinoline Etch
 - (f) 11 - goblet 34.00
 - (g) 11 - champagne 30.00
 - (h) 6 - sherbet 30.00

ALL ITEMS PRICED EACH. FIVE DAY RETURN PRIVILEGE WITH STICKERS/MARKS INTACT. UPS EXTRA - NO PARCEL POST SHIPMENTS. SEE YOU IN BOOTH #5 AT CONVENTION! 19th YEAR IN THE SAME SPOT. DO DROP BY!

ATTENTION ADVERTISERS

WE ARE HAVING PROBLEMS WITH MANY OF YOUR ADS. PLEASE TYPE, OR WRITE ON LINED PAPER. BE SURE TO DOUBLE SPACE FOR EASIER READING AND EDITING. LIST THE NUMBER, PATTERN, SIZE, ITEM, COLOR, DECORATION, NUMBER FOR SALE AND PRICE. PLEASE LIST ONLY THE NUMBER OF ITEMS WHICH GO IN THE SIZE AD YOU ORDER, AS FOLLOWS:

- 1/8 page - 9 items
- 1/4 page - 20 items
- 1/2 page - 20 items horizontal
- 1/2 page - 50 items vertical
- 1 page - 50 items

ALSO, PLEASE GET YOUR ADS IN BY THE 5TH OF THE MONTH i.e. JUNE 5 FOR JULY ISSUE. YOUR COOPERATION IN THIS WILL BE GREATLY APPRECIATED. THANK YOU!

DONALD P. BEAN PH: 508-473-0561
36 HARDING STREET SHIPPING EXTRA
MILFORD, MA 01757 * = MARKED

- 3357 King Arthur 10 oz goblets*, Moongleam bowl, Crystal stem & foot (4) ea \$ 17.00
 - 1519 Waverly 7" plates, Orchid Et (2) . . . ea 15.00
 - 300 Peerless toothpick holder 20.00
 - 1183 Revere individual salt, Flamingo . . . 15.00
 - 1469 Ridgeleigh sq ash trays* (6) . . . all 18.00
 - 341 Old Williamsburg punch cups, (7) 4½ oz* & (5) 3 oz* all 50.00
 - 1425 Victorian 2 oz bar* (2) all 30.00
 - 1503 Crystalite 3 oz oil & str* 25.00
 - 1295 Bead Swag opal ½ gal jug, good gold & excellent rose decor 95.00
- STILL NEED COVER FOR LG 1205 POTPOURRI JAR!

LEISURE CITY ANTIQUES AND COLLECTABLE FLEA MARKET MALL AT VANATTA, OHIO, ON ROUTE 13, FOUR MILES NORTH OF DOWNTOWN NEWARK. PHONE 745-5466

OPEN YEAR ROUND ON FRIDAY, SATURDAY AND SUNDAY 10 to 5. ALSO OPEN EVERY DAY JUNE 9 THRU JUNE 19. YOU ARE WELCOME TO BUY AND BROWSE AS LONG AS YOU LIKE - PLENTY OF FREE PARKING.

HEISEY, HEISEY BY IMPERIAL, DUNCAN MILLER, CAMBRIDGE, FENTON (new and old) AND OTHER FINE GLASSWARE. MANY DEALERS SELLING SUCH ITEMS AS CLOCKS AND WATCHES, TOOLS, TOYS AND GAMES, MARBLES, FURNITURE, MODELS AND JEWELRY. OUTSIDE DEALER SET-UP AVAILABLE AT \$3.00 A DAY.

H & R DIAMOND H
HELEN - BOB RAREY
1450 WHITE ASH DRIVE
COLUMBUS, OHIO 43204

PH: 614-279-0390
AFTER 5:30 P.M.
UPS & INS EXTRA
* MARKED

ALL 1469 RIDGELEIGH

Mayo w/Pewter underplate \$ 35.00
Vase #2* 33.50
Double Cone shaker (1 only) 15.00

2-handled Jelly* 32.50
2-handled, 2-compartment Jelly 35.00
Vase*, 8" (2) ea 75.00
Cup & Saucer* (5 sets) ea 32.50
7" Candelabra (2) pr 195.00
9" Salad Bowl* 72.50

9" Vase 57.50
3" round Ashtray* (3) ea 12.50
round Candleblock 22.50
6" Vase* (2) ea 22.50
13½" Torte Plate* 52.50

Oblong Tray* 35.00
Cov'd Cigarette Jar* 45.00
8" sq. Plate* (4) ea 32.50

Round Punch Cup* (4) ea 9.50
Cone Beverage Cup* (2) ea 16.50

6" Flared Vase, Sahara 125.00

ONCE & FUTURE ANTIQUES
9 DONNA ROAD
CHELMSFORD, MA 01824
STEVE & SUSAN PESCATORE

PH: 508-256-5418
UPS & INS EXTRA
* = MARKED

150 Banded Flute 9 oz goblets* (3) . . . ea \$ 15.00
300-0 Old Williamsburg 1-lite candelabrum,
complete, "A" prisms, (2) (mint) . pr 140.00
300½ Peerless #1 vase, 10½" * 70.00
341 Puritan 7" high-footed compotes* (2) ea 50.00
352 Flat Panel ice cream cone hldr, strght 35.00
433 Grecian Border 10" cheese & cracker* 90.00
1495 Fern twin mayo, handled 22.00
1200 Cut Block open sugar, Custard, rose dec 35.00
1200 Cut Block toothpick, Ruby flashed,
souvenir 60.00
1205 Fancy Loop medium cracker jar w/cover,
mint 175.00
1220 Puntly Band ind creamer, Custard . . 30.00
1503 Crystolite 2 oz oil btls w/stprs . . ea 28.00
1254 sherbets, 5½ oz* (9) ea 9.00
1295 Beaded Swag lemonade set, Opal w/rose
decor - ½ gal tankrd w/ (6) tmlrs, set 300.00
1519 Waverly 14" sandwich plate, Gardenia Et 30.00
1295 Beaded Swag 8 oz goblet, Custard,
souvenir 40.00
1295 Beaded Swag 8 oz goblet, Custard,
writing removed 25.00
1401 Empress 7" sq plates, Lafay Et (6) . ea 9.00
4044 New Era cordials (4) ea 25.00
1540 Lariat 11" cookie plate w/very unusual silver
overlay of geese in flight(photo on req)50.00

MANNY KLAWANS
2308 ASHBORO DRIVE
CHEVY CHASE, MD 20815

PH: 301-588-2755
UPS & INS EXTRA
SASE PLEASE

341½ Puritan 8 oz creamer, H \$ 65.00
354 Wide Flat Panel grapefruit, saucer
attached, H 35.00
465 Recessed Panel bowl 8", unk cut, H 45.00

500 Octagon Creamer & Tray, Flamingo, w/
Flamingo sticker, H 45.00
1184 Yeoman Marigold cup & saucer w/#440
Frontenac Etch, H 35.00
1184 Yeoman cov'd lemon dish, Flamingo, H 50.00
1184 Yeoman DO compote, Flamingo, H . 29.00
1193 Preserve plate, Flamingo, unk cut, H 37.50

1235 Beaded Panel & Sunburst spooner . 50.00
1255 Pineapple & Fan bud vase, 6" . . 30.00
1255 Pineapple & Fan #2 shaker 18.00
1255 Pineapple & Fan 6" rose bowl . . 60.00

1401 Empress 9" Sahara vase, 450½ Formal
Chintz Et, H 85.00
1489½ Puritan horsehead cigarette box 60.00
1503 Crystolite 3" short stem vase, H 30.00
1503 Crystolite ftd cigarette hldr, H 30.00

1509 Queen Ann h'lded bowl, 8½", 850 Del
Monte cut 45.00
1519 Waverly 12" bowl, Orchid Etch . . 60.00
1567 Plantation 6" compote, H 45.00
4206 Optic Tooth 8" vase, Flamingo, (V-3) 55.00

J & T ANTIQUES
BOX 933
STURBRIDGE, MA 01566-0933

PH: 508-347-5424
UPS & INS EXTRA
* MARKED

341 Puritan pitcher, 3 pint * \$ 45.00
341 Puritan pitcher, 1 qt w/cov - (cover
as is)* 48.00
355 Quator 4" nappies* (12) ea 5.00
407 Coarse Rib 9" celery tray, staidn gld* 25.00
433 Greek Key 7½" ftd banana split* . . 24.00

500 Octagon ice tub & tongs, no handle,
Moongleam * 35.00
1205 Fancy Loop small cracker jar, no top 35.00
1252 Twist oval hotel cream & sugar, Moon-
gleam * 45.00
1401 Empress triplex relish, silvr overlay* 35.00
1401 Empress 8" flared vase, gold Etching* 36.00
1401 Empress 13" 2-compartment relish* . 18.00

1404 Old Sandwich 10 oz low ftd goblets(2) ea 18.00
1433 Thumbprint & Panel floral bowl, Sahara 85.00
1495 Fern twin mayo* 25.00
1495 Fern 11" oval floral bowl* 35.00

1519 Waverly Orchid Etch 14" torte plate . 45.00
1567 Plantation footed sugar & creamer . . 48.00

1567 Plantation 3-compartment relish * . . 36.00

CLASSIQUE GLASS CO.
P.O. BOX 52572
TULSA, OK 74152

PH: 918-744-5409
MINT MOST MKD.
UPS EXTRA

* JAMES S. HARRIS
* ANTIQUES/APPRAISALS
* BOX 672
* RICHMOND, KY 40475

PH: 606-623-9100
UPS & INS EXTRA
H = MARKED

PRE-CONVENTION SPECIAL ITEMS AND PRICES !!!!!

160 Locket on Chain 4" bowl (2) \$ 48.00
 433 Greek Key compute 80.00
 433 Greek Key ftd banana split (2) . . . 33.00
 433 Greek Key 3 pint jug 160.00
 372 McGrady sanitary syrup, Flamingo . . 77.00
 5025 Tyrolean low goblet, #517 Orchid Et (4) 38.00
 1170 Pleat & Panel 8" bowl, Flamingo . . 39.00

1184 Yeoman D0 12 oz tumbler, Moongleam (3) 30.00
 1184 Yeoman D0 demitasse cup & sau, Flamingo 36.00
 1205 Raindrop 2" c'stick, Moongleam . . pr 45.00
 1252 Twist 4 oz oil, Lightng hdl, Sahara 95.00
 1252 Twist 4" plate (coaster), Moongleam 15.00
 1252 Twist Flamingo, numerous - call/write

1401 Empress 11" floral bowl, Moongleam 88.00
 1401 Empress 11" floral bowl, Sahara . . 85.00
 1401 Empress 8" sq plate, Cobalt (6) . . 66.00
 1401 Empress cup/saucer, Sahara (3) . . 35.00
 1401 Empress 8" vase, Antarctic Etch . . 125.00
 1404 Old Sandwich oyster cocktail, Sahara 29.00
 1404 Old Sandwich 8" sq plate, Moongleam 30.00
 1404 Old Sandwich 8 oz tumbler (4) . . . 17.00

1405 Ipswich candle vases, complete with inserts and bobeches pr 195.00
 1417 Arch tumbler, Cobalt (6) 85.00

1425 Victorian punch cup (5) 14.00
 1425 Victorian 5 oz sherbet, Sahara (3) 45.00
 1433 Thumbprint & Panel 2-lite c'sticks pr 425.00
 1495 Fern 2-lite c'sticks complete with bobeches & prisms pr 77.00

5067/516 Plantation Ivy Et goblet (5) . . 29.00
 5067/516 Plantation Ivy Et sherbet (4) . . 25.00

3360 Penn Charter goblet, Flamingo (2) . . 33.00
 3360 Penn Charter champagne, Flamingo (2) 26.00
 3360 Penn Charter champagne, Hawthorne 55.00

3355 King Arthur champagne, Flamingo (4) 22.00
 3362 Charter Oak goblet, Moongleam (4) . . 30.00
 134 Trident 2-lite c'sticks, Sahara . . pr 165.00

135 Empress 7" 1-lite c'sticks, Sahara pr 160.00
 1519/507 Waverly Orchid Et cream/sugar . . 75.00
 1519/507 Waverly Orchid Et individual cream & sugar 75.00

Rectangular cov'd horsehead finial . . . 77.00
 Giraffe, head turned to right 190.00
 Goose, wings half 75.00
 CHILDS TOY HORSEHEAD, frosted, scarce, 1" 90.00

WANTED FOR RESALE: OLD GLORY STEMS WITH RENAISSANCE ETCH, ESPECIALLY CLARETS, ICES ETC. & HEISEY ROSE ETCH STEMS, ESPECIALLY FTD JUICES.

HAVE FUN AT THE HCA CONVENTION. DRIVE SAFE!

* 1225 Sawtooth (Plain) Band 4oz cruet w/stpr \$ 37.50
 * 333 Waldorf Astoria 4 oz cruet w/stpr . . 40.00
 * 1205 Fancy Loop 4 oz cruet w/stopper . . . 50.00
 * 473 Narrow Flute w/Rim cruet w/stopper, H 32.50
 * 300 Peerless 4 oz cruet w/stopper 47.50
 * 1506 Provincial tall cruet w/stopper . . . 42.50
 * 1540 Lariat cruet w/stopper 75.00
 * 1184 Yeoman 3 oz cruet w/stopper, H . . . 35.00

* 417 Double Rib & Panel cruet w/stpr, H . 35.00
 * 1469 Ridgeleigh 3 oz cruet w/stopper . . . 67.50
 * 1405 Ipswich cruet w/stopper 80.00
 * 1425 Victorian cruet w/stopper 37.50
 * 1252 Twist tall cruet w/stopper, Flamingo 47.50
 * 333 Waldorf Astoria 6 oz cruet w/stpr, H 52.50

* 4225 Cobel 1 qt cocktail shkr, complete 47.50
 * 1401 Empress 10" oval veg., Sahara, H . . 42.50
 * 1401 Empress 14" oval platter, Sahara . . 32.50
 * 433 Greek Key 4½" plates, H, 5 for . . . 55.00
 * 353 Medium Flat Panel 4 oz oil, H 13.50
 * 468 Octagon w/Rim 12" celery, Flamingo, H 37.50
 * 1150 Colonial 8" plate, H 11.00
 * 393 Narrow Flute 9" plate, H 15.00

* 1519 Waverly candle epergnettes, H . . . pr 30.00
 * 3312 Gayoso goblet, dbl. loop needle etch 8.00
 * 1404 Old Sandwich ind. ashtray, H, 4 for 32.50

* 1503 Crystalite ind. sugar & cream on tray, H 45.00
 * 4044 New Era 2 oz bar, 6 for 60.00
 * 351 Priscilla covered mustard, H 40.00
 * 3389 Duquesne cordial 27.50
 * 5024 Oxford cordial, H 25.00

* 6092 Cabachon goblet w/Debutante cutting . 22.50
 * 5040 Lariat goblet w/Ivy cutting, H . . . 20.00

* 1454 Diamond Point ind. ashtray, H, 6 for 36.00
 * 1252 Twist 1-lite 2" candlestick, Flamingo, H 40.00
 * 1454 Diamond Point ind. jelly, H, 10 for . 45.00

* 7000 Sunflower 14" sandwich plate, H . . . 50.00
 * 7000 Sunflower 13" floral bowl, H 50.00
 * 1404 Old Sandwich 6" comport, H, & pap label 40.00

* 350 Pinwheel & Fan 8" nappy, grnd btm, H 50.00
 * 1184 Yeoman 9" luncheon plate, Flamingo, (12) ea 11.00
 * 1184 Yeoman cup & sau, Flamingo, H, (10) ea 22.50

* 1229 Octagon ind. almond, Flamingo, H . . 16.00
 * 1184 Yeoman 7½" plate, D0, Flamingo, 6 for 48.00
 * 3542 Hazelwood oyster cocktail w/etching, H 4 for 37.50

* BUYING INDIVIDUAL PIECES, COLLECTIONS, LIDS, TOPS,
* AND ADVERTISING ITEMS.

* WRITE AND DESCRIBE FOR PROMPT REPLY.

14th Annual
**NATIONAL
 CAMBRIDGE
 COLLECTORS'**
ANTIQUÉ SHOW & SALE

(& 16th Annual NCG Convention)

SHENANDOAH INN
 INTERSTATE 70 - EXITE 186 - 7 MILES EAST OF
 CAMBRIDGE, OHIO

JUNE 23, 24, 25, 1989

FRIDAY, JUNE 23rd	5:00-8:00
(PREVIEW ADMISSION \$3.50)	
SATURDAY, JUNE 24th	11:00-5:30
SUNDAY, JUNE 25th	12:00-5:00
(ADMISSION \$2.00)	

OFFERING CAMBRIDGE AND OTHER FINE GLASSWARE
 including Heisey, Imperial, Fenton, Duncan, Tiffin, etc.

1989 NINTH ANNUAL

**Fostoria Glass
 Society**
**CONVENTION
 SHOW & SALE**

DEL F NORONA MUSEUM
 Moundsville, West Virginia

Friday, June 9, 1989	Premiere Admission \$4.00
Premiere Show and Sale	6:00 P.M. - 9:00 P.M.
Saturday, June 10, 1989	General Admission \$2.00
Show and Sale	11:00 A.M. - 5:00 P.M.
Glass Auction	6:00 P.M. - 10:00 P.M.
Sunday, June 11, 1989	
Flea Market	10:00 A.M. - 5:00 P.M.
Former Fostoria	2:00 P.M. - 4:00 P.M.
Employee Reunion	
Show and Sale	11:00 A.M. - 5:00 P.M.



For Information, Contact:
 Fostoria Glass Society of America, Inc.
 P.O. Box 826
 Moundsville, WV 26041



**13th ANNUAL
 NATIONAL
 IMPERIAL GLASS
 COLLECTORS'
 SOCIETY CONVENTION**

Stone Crab/Hospitality Inn
 St. Clairsville, Ohio

SHOW & SALE

Saturday, June 10 1:00 p.m. to 4:00 p.m.
 7:00 p.m. to 9:00 p.m.
 Sunday, June 11 12:00 noon to 4:00 p.m.
 Donation

SEMINAR

Heisey by Imperial By Tom Felt
 Saturday, June 10 9:00 a.m. to 10:00 a.m.
 OPEN TO PUBLIC • FREE ADMISSION

BANQUET

Saturday, June 10 5:00 p.m.
 OPEN TO PUBLIC • BY RESERVATION

FOR INFORMATION, WRITE:
 National Imperial Glass Collectors' Society
 P.O. Box 534 • Bellaire, OH 43906
 or Phone (614) 676-2422 • (614) 676-9827

• TIFFIN • DUNCAN MILLER • FENTON • HEISEY •
*The National Duncan
 Glass Society*
 Fourteenth Annual Duncan Convention Show and Sale
 Hand-House Glass of America
 July 22 11:00 A.M. to 5:00 P.M. July 23 11:00 A.M. to 5:00 P.M.
HOLIDAY INN MEADOWLANDS
 WASHINGTON, PENNSYLVANIA
 179 N. of Washington, PA Racetrack Rd. Exit
 ADMISSION: \$2.50
 For Information Call: 222-6376
 • NEW MARTINSVILLE • PADEN CITY • MORGANTOWN •

CAMBRIDGE • FRY • FOSTORIA
 IMPERIAL • PHOENIX • SENECA

THE NATIONAL DEPRESSION GLASS ASSN. INC.
**FIFTEENTH ANNUAL CONVENTION
 SHOW AND SALE**
 CHICAGO, ILLINOIS
 Pleasant Run Convention Resort (MegaCenter)
 (Route 64, St. Charles, IL 60174)
JULY 8 & 9, 1989
 Sat. 10 a.m. - 5 p.m. Sun. 11 a.m. - 5 p.m.
 Admission: \$3.50 (good both days)
 Top quality dealers from across the United States
 present an outstanding display of Depression Era Glassware
 including Cambridge, Heisey, Fenton & Fostoria; china; pottery
 and related items of the era.
DISPLAYS! SLIDE PROGRAMS! SEMINARS! SPECIAL GUESTS! DOOR PRIZES!
 Information: Dan Kramer
 P.O. Box 1201
 Pekin, IL 61554 (309) 353-2405
 50¢ off with this card

WE NEED YOU!!! VOLUNTEERS ARE THE HEART OF HCA!!

Please fill out below and return to Liz Stickle, PO Box 4367, Newark, OH 43055.

MUSEUM GIFT SHOP:

Hours: Thursday, Friday, Saturday 9:00 A.M. to 4:00 P.M. and Sunday 12:00 to 4:00 P.M.

DAY:	TIME:	NAME:

OSU BRANCH - ADENA HALL OR HOPEWELL HALL:

Hours: Thursday - 7:00 PM to 9:00 PM, Friday - 12:00 PM to 5:00 PM
Saturday - 11:00 AM to 6:00 PM, Sunday - 12:00 PM to 5:00 PM

DAY:	TIME:	NAME:

Will be available to be on a stand by volunteer basis to do what ever may be needed done.

DAY:	TIME:	NAME:

OSU BRANCH - GOLF CART DRIVERS

Hours: Thursday - 7:00 P.M. to 9:00 P.M. Friday - 12:00 P.M. to 5:00 P.M.
Saturday - 11:00 A.M. to 6:00 P.M. Sunday - 12:00 P.M. to 5:00 P.M.

DAY:	TIME:	NAME:

<p>A.W. PARKER Heisey & Pattern Glass Shows or Appointment Magalia, CA 95954 PH: (916) 873-2326</p>	<p>GLASS WITH CLASS Lenore A Shelley, GGHC 1336 Lincoln Avenue San Jose, CA 95125 PH: (408) 286-8098</p>	<p>OLDE LOVED THINGS 900 Ridgewood Ave. (Holly Hill) Daytona Beach, FL 32017 (904) 252-7960 Hours: Sat., Sun., & Mon., 10-4</p>
<p>ALL HEISEY AUCTION Consignments Welcome Apple Tree Auction Center 1616 W. Church, Newark, OH 43055 PH: (614) 344-9449</p>	<p>GREEN ACRES FARMS Antiques, Crystal Glass & Collectibles 2678 Hazelton-Etna Rd., SW (S.R. 310-N) Pataskala, OH 43062 Sat. or Sun. PM or call (614) 927-1882</p>	<p>YOUR AD COULD BE HERE</p>
<p>ALFA I CARRIAGE HOUSE ANTIQUES Featuring Depression & Elegant Glassware Al & Faye Maness 508 E. Cary Street Richmond, VA 23219 PH: (804) 788-1630</p>	<p>H & R DIAMOND H Helen & Robert Rarey 1450 White Ash Dr. Columbus, OH 43204 PH: (614) 279-0390 after 5:30</p>	<p>PARRETT'S ANTIQUES Heisey 4994 Mapledale Rd. OR 1215 Greenwood Ave. Jackson, Mich. 49201 PH: (517) 784-7319 OR (517) 783-3289</p>
<p>ANTIQUES - THE SHULTZES 206-208 East Main St. Newmanstown, PA 17073 15 Miles West of Reading, PA PH: (215) 589-2819</p>	<p>"HAPPINESS IS" - THE STULTZS 3106 Warren Court, Glen Allen, VA 23060 Shows and Mail Order PH: (804) 262-1273 GLASS CIRCA 1890-1960</p>	<p>PATTON HOUSE Heisey & Duncan Miller Rocky's Mall, 1-81 & US 11 Weyer's Cave, VA 24486 PH: (703) 967-1181</p>
<p>C & J ANTIQUES Cole & Jean Miesner Box 45, 72 Whig St. Newark Valley, NY 13811 PH: (607) 642-9905</p>	<p>HARRALSON'S HEISEY HUNTERS Sponsor: S.W. MO's Antique Shows 78 Quality Dealers From 14 States 1989 Dates: Apr. 29-30 & Oct. 28-29 Info: 1426 W. Highland, Springfield, MO 65807 PH: (417) 883-2449</p>	<p>EAGLES REST ANTIQUES Carl and Mary A. Evans Heisey - China - Pottery, etc. Shows or Appointment PH: (614) 522-2035</p>
<p>GLASS RESTORATION LeRoy Carter, Jr. 125 Maple Ave. Utica, Ohio 43080 Phone 614-892-2775</p>	<p>HELEN & JIM KENNON Heisey, Cambridge, Fostoria, Duncan, Imperial, Fenton, Tiffin P.O. Box 114 Brookville, OH 45309 PH: (513) 833-5406 SHOWS ONLY</p>	<p>R & L ANTIQUES-SAN FRANCISCO Members of the Golden Gate Heisey Club 3690 Bodega Ave. Petaluma, CA 94952 PH: Petaluma (707) 762-2494 PH: San Francisco (415) 621-6693</p>
<p>CHARLES & MILDRED FISHER Heisey, Degenhart, Imperial, Antiques, Collectibles, General Line 991 Idlewilde, Newark, OH 43055 PH: (614) 522-5398</p>	<p>JJ MC KEE ANTIQUES Pottery - Glassware - Collectibles 222 B West 75th St. Kansas City, MO 64114 Wed.-Sun. 10-5 PH: (816) 361-8719</p>	<p>THE WOODEN SHOE Antiques & Collectibles Jim & Sheri VanEs by Appt. 810 Eiden, Herndon, VA 22070 PH: (703) 435-9045</p>
<p>DAVE'S ANTIQUES Specializing in Heisey Shows & Mail Order 1403 E. Knollwood St. Tampa, Fl. 33604 (813) 237-5550</p>	<p>THE PURPLE PLACE Featuring Heisey & Other Fine Glass Martha & Harold Earp 1940 Suwanee, Ft. Myers, FL 33901 PH: (813) 936-1572 Anytime</p>	<p>SCHWAN'S ANTIQUES SHOWS & MAILORDER 77 Lagos del Norte Ft. Pierce, FL 34951 PH: (407) 461-5940</p>
<p>DIAMOND H PLUS Mail Orders & Shows George & Eileen Schamel Rt. 3, Box 171, Boonsboro, MD 21713 PH: (301) 432-6285</p>	<p>J. & R. COLLECTIBLES Shows, SASE, Mail Order list June & Ray Lukasko P.O. Box 1030, Newark, OH 43055 PH: (614) 344-9719</p>	<p>SHOW AND TELL ANTIQUES Art, Cut, Heisey and Pattern Glass 1525 Morrow Ave., Waco, TX 76707 Tues-Sat 10:30-4:30 PH: (817) 752-5372 Also: Mail Order and Shows Member NADA</p>
<p>ETTELMAN'S DISCONTINUED CHINA & CRYSTAL HEISEY a SPECIALTY P.O. Box 6491-HN Corpus Christi, TX 78411 PH: (512) 888-8391 Include SASE</p>	<p>MOSTLY HEISEY Rhoda Curley 16 Clayton PL, Albany, NY 12209 Shop and Mail Order PH: (518) 482-6272</p>	<p>HEISEY PUBLICATIONS Box 102, Plymouth, Ohio 44865 All Vogel Heisey Books I, II, III, IV And Quarterly Newscasters available</p>
<p>FOREVER HEISEY Jan & Norm Thran Mail Order, Shows, Appraisal Service 1663 Londondale Pkwy., Newark, OH 43055 PH: (614) 344-5955</p>	<p>MOUND BUILDERS ANTIQUES Heisey & Animals, General Antiques Irene Rauck 1138 Moundview, Newark, OH 43055 PH: (614) 344-6043</p>	<p>WILLEY'S ANTIQUES & MUSEUM Specializing in Heisey 11110 Cannon Rd., Frazeytsburg, OH 43822 16 miles east of Newark, OH PH: (614) 828-2557</p>
<p>GERT'S GLASS Heisey & Duncan Gertrude & Russell Swetnam 1926 Saratoga Dr., Adelphi, MD 20783 PH: (301) 434-5113</p>	<p>THE MUTED SWAN ANTIQUES 5486 Peachtree Rd., Chamblee, GA 30341 Heart of Chamblee Antique Row Specializing in Heisey & Cambridge Bill & Pat Miller PH: (404) 451-7620</p>	<p>YOUR AD COULD BE HERE</p>
<p>GLASS 'N' GLASS Virginia & Odell Johnson Rt. 1, Box 1324 Hayward, WI 54843 PH: (715) 462-3753</p>	<p>NANCY'S ANTIQUES Heisey, Cambridge, Fostoria, Fenton Mail Order 906 44th St. NW, Canton, OH 44709 216-492-2595. Shop Union Station Antiques 12622 Cleveland Ave., Uniontown, OH Daily</p>	<p>TALL OAKS ANTIQUES 565 N. Nichols St., Lowell, IN 46356 Elegant & Dep Glass Specializing in Heisey. Shows - Mail Order - 219-696-0147 Mike & Barb Rosenberger</p>



*Heisey Presents
Christmas
In
June*

EIGHTEENTH ANNUAL CONVENTION

JUNE 15, 16, 17 & 18, 1989

**CONVENTION HEADQUARTERS
BEST WESTERN INN
SECOND AND CHURCH STREETS**

THE Museum will be open at 9 A.M. daily except Sunday when it will open at 12 P.M. The lounge will open for refreshments at 1 P.M. on Wednesday, June 14. The Museum and lounge will close at the same time as the Show and Display except Thursday when it will close at 4 P.M. Hours during which the warehouse will be open will be posted at convention time.

CALENDAR OF EVENTS:

WEDNESDAY, JUNE 14

1. REGISTRATION: EVERYONE MUST REGISTER. Packets may be picked up at the Museum beginning on June 14. Remember that registration badges are required for all events; they permit unlimited admission to the SHOW AND DISPLAY AND TO ALL FREE ACTIVITIES. Children under 12 will be admitted free except where food is served.

PRE-ORDERED OSCARS may be picked up at the Museum. Remaining Oscars (if any) will be sold at the Museum.

THURSDAY, JUNE 15

1. REGISTRATION CONTINUES
2. "T'WAS THE NIGHT BEFORE CHRISTMAS"



H.C.A. MUSEUM 9 A.M. to 1 P.M.

Adena Hall, OSU - COTC. Show Preview includes a Turkey and Ham Dinner under a tent from 5 to 7 P.M. Show hours are from 6 to 9 P.M. Hopewell Hall Display hours are 7 to 9 P.M.

FRIDAY, JUNE 16

1. REGISTRATION CONTINUES
2. "THE WISE MEN"
3. ANTIQUE SHOW - "SANTA'S WORKSHOP"
4. DISPLAY - "WINDOW SHOPPING"
5. "SANTA'S ELVES"
6. "HOLIDAY FEAST"

H.C.A. MUSEUM 11 A.M. to 4 P.M.

Best Western - 8:30 A.M. Bring FINDS AND QUESTIONABLE HEISEY for identification. A panel of knowledgeable individuals will assist. A continental breakfast will be served. Introduction of candidates for Board of Directors.

Adena Hall 12 to 5 P.M.

Hopewell Hall 12 to 5 P.M.

Reception for HCA MEMBERS & FORMER HEISEY WORKERS. Buckingham House (two doors from Museum) 1 to 3 P.M.

Convention banquet at the Best Western Inn. Social Hour begins at 6:30 P.M. and Dinner at 7 P.M. Study Club Reports will be given. PROGRAM: Christmas Bell Choir and introduction of candidates.

SATURDAY, JUNE 17

1. FLEA MARKET
2. REGISTRATION CONTINUES
3. ANTIQUE SHOW



On the square at daylight.

HCA MUSEUM 10 A.M. to 12 P.M.

Adena Hall 11 A.M. to 6 P.M.

- 4. DISPLAY
- 5. SEMINARS*



Hopewall Hall at 11 A.M. to 6 P.M.

All at the Best Western Inn.

1:30 to 2:30 P.M.

"The Color Moongleam" by Walter Ludwig
An in-depth discussion on Heisey's Moongleam color. Examples from the speaker's collection will be on display.

2:30 to 3:30 P.M.

"Heisey Favor Vases" by Glen & Joyce Rohde
A look at the design and colors of favor vases produced by Heisey. Examples from the speaker's collection will be on display.

3:30 to 4:30 P.M.

"Insurance on Glassware & Other Antiques" by Mike Thompson from Baker-Schnaidt Fairfax Insurance Agency

- 6. SWAP - "RETURNS & EXCHANGES"

7:30 P.M. at the Best Western Inn for members only. A trading post for Heisey Glass will be set up. Bring your duplicates or other Heisey to trade for Heisey of your choice. Each family will be permitted a maximum of 12 items on the table at any one time. These items will be for trade only. Absolutely no money will be involved in the exchange.

YOU WILL NOT BE ADMITTED WITHOUT YOUR BADGE.

A SILENT AUCTION WILL ALSO BE HELD.



SUNDAY, JUNE 18

- 1. FLEA MARKET
- 2. "HEADIN' HOME FROM THE HOLIDAYS"
- 3. ANTIQUE SHOW
- 4. DISPLAY

On the square at daylight.

Buffet Breakfast - 8:00 A.M. Best Western Inn
H.C.A. Annual Meeting and election of Directors

Adena Hall - 12 to 5 P.M.

Hopewall Hall - 12 to 4 P.M.

DEADLINE FOR REGISTRATION - MUST BE POSTMARKED BY JUNE 8

<u>EVENTS:</u>	<u>COST</u>	<u>NO. ATTENDING</u>	<u>TOTAL PER ITEM</u>
REGISTRATION	\$ 7.00 **	_____	_____
TWAS THE NIGHT BEFORE CHRISTMAS	7.00 ***	_____	_____
THE WISE MEN	4.00	_____	_____
SANTA'S ELVES	2.00	_____	_____
HOLIDAY FEAST	11.50	_____	_____
HEADIN' HOME FROM THE HOLIDAYS	5.00	_____	_____
TOTAL COST OF ALL EVENTS	\$36.50	_____	_____

Make check payable to Heisey Collectors of America, Inc.

MAIL TO:

- * No pre-registration needed for seminars.
- ** \$10.00 if not pre-registered.
- *** Dealer Registration Fee is included in your booth rent. Dealers must check, and pay for, any other event which they plan to attend. (2 people per booth.)

MRS. ROBERT MCCLAIN, REGISTRATION
336 Meadowbrook CHAIRMAN
Newark, OH 43055
PH: 614-366-7087

Please list EACH NAME as you wish it to appear on EACH BADGE. Check all events you plan to attend.

NAME(S) _____

STREET _____ CITY _____ STATE _____ ZIP _____



YOU ARE CORDIALLY INVITED TO ATTEND OUR

"CHRISTMAS EVE SNEAK PEAK"

PREVIEW AT APPLE TREE AUCTION CENTER
ON FRIDAY JUNE 16TH AFTER THE H C A
BANQUET. DOORS WILL OPEN AT 9:00 P M
PLEASE COME JOIN US
FOR SOME YULETIDE CHEER!



SATURDAY AUCTION STARTS AT 8:00 A M - DOORS WILL OPEN AT 7:00 A M

ONE OF THE "HIGHLIGHTS" OF OUR JUNE AUCTION WILL BE A PR OF BEAUTIFUL RARE ZIRCON DOLPHIN CANDLESTICKS; RARE PROVINCIAL BOWL IN SAHARA; MANY NICE PIECES IN SAHARA EMPRESS, SEV WITH OLD COLONY ETCH; ITEMS IN CRYSTOLITE, COLONIAL & MANY OTHER PATTERNS; COBALT GASCONY GOBLETS, COBALT BALL VASE; AN EXCELLENT SELECTION OF SMALL ITEMS INCLS APPROX 30 TOOTHPICK HOLDERS IN EMERALD, RUBY STAIN, OPAL & CUSTARD; APPROX 25 PCS OF PLANTATION; ITEMS IN ORCHID ETCH, DEEP PLATES ETC.. ALSO OFFERED WILL BE HEISEY ANIMALS AND A GREAT SELECTION OF DESIRABLE AND SCARCE HEISEY BY IMPERIAL ANIMALS ETC., IN MANY COLORS. SOME OF THESE ARE - AMBER FLYING MARE, FILLYS, CLYDESDALE, TIGER PAPERWEIGHT, SOW, ASIATIC PHEASANT, GIRAFFE & OTHERS; MANY CARAMEL SLAG INCLUDING THE HARD TO FIND ONES; THERE ARE PINK, DARK GREEN, LIGHT GREEN, DARK BLUE, LIGHT BLUE (MOTHER RABBIT), CHARCOAL, YELLOW, NUT BROWN ETC.. SOME ARE PLAIN, SOME FROSTED, SOME IRIDIZED - YOU MUST COME AND SEE THE VARIETY. THERE IS MUCH MORE - SOME TO COME YET - SEVERAL PIECES IN TANGERINE.

APPLE TREE AUCTION CENTER
1616 W CHURCH STREET
NEWARK, OHIO 43055

SAM SCHNAIDT & TIM HUGHES - AUCTIONEERS
(614) 344 - 4282
FRANK FRYE - MANAGER

CATALOGS AVAILABLE FROM AUCTIONEERS FOR \$1.50

**National Heisey
Glass Museum**

*Eight rooms and
complete lower level
displaying the beautiful
hand made glass*

*produced in Newark by the A.H. Heisey and Co. from
1896-1957.*



Corner of West Church & North Sixth Streets
Newark, Ohio 43055

Phone: (614) 345-2932

Hours: Daily 1pm-4pm Closed Holidays

OHIO
the heart of it all! SM

Membership Renewal Notice

The date above your name and address
is your renewal date. This is your last
issue of the Heisey News if it reads
6-30-89

PLEASE DISREGARD THIS NOTICE IF YOU HAVE
RECENTLY PAID YOUR DUES.

POSTMASTER SEND FORM 3579 TO:



SECOND CLASS