

HEISEY *news*

OFFICIAL PUBLICATION HEISEY COLLECTORS OF AMERICA

©Heisey Collectors of America, Inc. 1981
All Rights Reserved

VOLUME X NO. 1 JANUARY, 1981

ONE DOLLAR



No. 1489 PURITAN OIL & VINEGAR and BITTERS BOTTLE

INCREASE IN ADVERTISING RATES

Due to greatly increased costs, we find it necessary to increase the advertising rates in HEISEY NEWS. Our old rates have been in effect since July, 1975. Five and a half years is a long time to hold down the cost of advertising. During this time our membership has grown from 1700+ to over 5000, so your ads are also reaching many more people.

EFFECTIVE IMMEDIATELY the new rates will be as follow:

Display Ads:	Member:	Non-Member:
1/8 page - 9 items	\$12.00	\$20.00
1/4 page - 20 items	20.00	30.00
1/2 page - 20 items (horizontal ONLY)	35.00	45.00
1 page - 50 items	60.00	75.00

Classified Ads:

10¢ a word; \$1.00 minimum.

Dealers' Directory:

Due to the extra work involved, subscriptions will only be accepted for 1 year intervals. The rate is increased to \$18.00 per year for 5 lines/month. Any changes during the year require payment of an extra \$1.00 per line.

- Neila Bredehoff, Advertising

HEISEY NEWS---P.O. BOX 27---NEWARK, OHIO 43055

EDITOR-LOUISE REAM, Box 27, Newark, Oh. 43055
 ASS'T EDITOR-NEILA BREDEHOFT, Box 27, Newark, Oh. 43055
 PUBLISHED MONTHLY-\$12.00/year-\$1.00/copy
 BACK ISSUES AVAILABLE AT \$8.00/year-\$1.00/copy

PRESIDENT	LOUISE REAM	(614) 344-2377
VICE PRESIDENT	JACK METCALF	(614) 892-2664
SECRETARY	MARY McWILLIAMS	(614) 345-4380
TREASURER	DICK MARSH	(614) 366-5608

Heisey Collectors of America, Inc. is a non-profit corporation with tax exempt status. Owners and operators of National Heisey Glass Museum, 6th. & Church Streets, Newark, Ohio. Open Daily 1-4p.m. March through December except Mondays and Holidays. January & February-Wednesday, Saturday, Sunday 1-4p.m. Other times by appointment. Members admitted free.

PHONE (614) 345-2932. Club membership (Includes 12 issues of Heisey News and participation in all club activities) \$12.00/year plus \$2.00 each for additional family members in same household who wish a membership card. For VOTING MEMBERSHIP add \$25.00, one time only fee, or write for information.

FOR MEMBERSHIP-HCA MEMBERSHIP, BOX 27, NEWARK, OH. 43055. Notify immediately of any change of address.

.....
 The opinions expressed in articles in Heisey News are those of the authors and not necessarily those of the organization. The Editorial Staff reserves the right to edit or refuse any material submitted for publication. When requesting information, please enclose a self addressed stamped envelope(SASE).

ADVERTISING- Send all ads to:
 Neila Bredehoff, Advertising
 Box 27
 Newark, Ohio 43055
 DEALERS' DIRECTORY-5 lines - \$18.00/year.

CLASSIFIED-10¢/word. \$1.00 minimum.
 Abbreviations and initials count as words.

DISPLAY:	MEMBER	NON-MEMBERS
1/8 pg (9 items)	\$12.00	\$20.00
1/4 pg (20 items)	20.00	30.00
1/2 pg (20 items)	35.00	45.00
1 pg (50 items)	60.00	75.00

We will not double-column ads. No VERTICAL 1/2 page ads. ALL ADS MUST BE PREPAID. Ad copy must be received by the 5th. of the month to be included in that month's NEWS. ads containing reproductions will not knowingly be accepted unless clearly stated (i.e. Heisey by Imperial, etc.) HEISEY NEWS assumes no responsibility for false advertising or misleading information. In the event of typographical error, the incorrect portion of the ad will be run in the following issue, but HEISEY NEWS assumes no further liability.

.....
 Send all letters and articles to be published to the EDITOR. Letters to columnists should be sent to the club address and will be forwarded.

FROM THE DESK OF YOUR PRESIDENT

We have now embarked on our tenth year with the Actual Founding date being October 15, 1981. We plan to celebrate all year long. This is the 109th issue of Heisey News which has been printed. Very few things have ever been repeated, except for updating, so you can imagine the amount of Heisey information in 108 issues. We would not have believed in 1971 that this would be possible but knowing the amount of material which we have, I suppose we can keep on writing forever (?). We still have extra copies of Heisey News printed every month and at present, eight volumes are available (all but 1974) and are only \$8.00 per set. New members are amazed at the wealth of information in these.

We are rapidly approaching 5200 members and with a little help from all of you perhaps we can make it by Convention time. We remain the largest handmade glass club, and by far the most active, in America today.

The Golden Gate Heisey Collectors Club will be chartered in June as #33. This is the second study club in California and promises to be another large and active club. We welcome all of you, and Congratulations! We look forward to meeting many of you and to presenting your Charter in June.

After a little over three years of working for HCA, Debbie Delaney has resigned to take another job in Columbus, Ohio, where she plans to move. We wish her the best of luck in her new position. Merrell Strawn, who was doing our shipping, has taken over Debbie's job and will be keeping your memberships. We have hired another woman, Margaret Weber, to do the shipping.

Merrell asks that you be patient with her until she learns the ropes. There was a backlog of December renewals since that is our biggest month but as of today, January 15th, she is caught up and you should have all received your membership cards. If you have any problems, just write to us. A few people may have received blue cards instead of red, if so, let us know. (Red cards are for Voting members).

Many of you apparently have not read the notice in the last three of four newsletters to the effect that dues, as of January 1, are \$12.00 for the first member and \$2.00, each additional household member. It would help us all very much if from now on you would send the proper amounts.

1980 was our biggest year to date in the Gift Shop and Mail Order Sales, over \$18,000. It was a year of expansion in terms of membership and, of course, we went from one full time paid employee to a paid staff of three, including Wanda Lybarger, our bookkeeper. And the part time help seems to be expanding to near full time for at least one of them.

In corresponding with HCA, please be sure to look at the updated masthead and many of your questions may be answered. Take special note of the new Advertising rates! The same price for $\frac{1}{2}$ and $\frac{1}{2}$ page ads may be confusing but you will be able to put much more description in the horizontal half page. The $\frac{1}{4}$ is not large enough for so much added information. PLEASE send PAYMENT with your ads.

We advertise a 24 page newsletter, and so it is, but this month's issue has the 1980 index which caused us to cut the rest of it to 22 pages to stay within 28¢ Postage.

There is a lot of Auction Glass on hand, but more here to be unpacked, so we don't know what we have nor if it is enough for a 2 day affair but judging from the amount of boxes there must be. We will be sending out a separate mailing on the Auction in plenty of time for you.

We've heard of an 1150 8" plate in Alexandrite, a real goodie, the seldom seen 3334 Sexton goblet with a cutting, a 1637A Town & Country plate in experimental black, and 110 Dolphins in Flamingo. You'll be reading all of this in your list when it arrives. It is sure to be a good Auction and will be worth attending. See the rules for mail bidding in this issue. Bob Johnson, Mailman #1, has agreed to do the bidding again this year. Auction Co-Chairmen are Ray Ziegler and John Eshelman.

The Oscars are in and are beautiful. We have started sending out those already ordered as we need to get them out of the shipping room to make more space. The "March" Cygnet, which was made early this year, has already arrived so we will be selling them now as well. They are light blue and the cost is \$13.25 plus 10% Shipping and 5½% Sales Tax in Ohio. Tax went up 1% and Newark already had 4½% tax. Exact counts cannot be given on these animals as we don't have the complete orders, but Oscars should be 2600 or less, and Cygnets 1500 or less.

George Long of Dayton, Ohio sent us the Article about Wilson Heisey's Cabin. There were newspaper pictures with it but we are afraid they would not copy well. Later we may be able to find some original pictures of this fabulous Cabin (?).

Thank you for all of the Christmas Cards and letters. Eventually when we get settled down again I'll get them all answered.

We have had cold and snow here but the Office has been open every day. You can also come to the Museum Gift Shop any day by coming first to 169 W. Church, our Office Building. Beginning March 1st we will start our Spring and Summer schedule for the museum rather than waiting until April.

Happy Collecting!

Louis Bean

- 5002 SWEET ADELINE CARVING
- 5004 SCOTCH CARVING
- 5005 BOURBON CARVING
- 5006 GIN CARVING
- 5007 RYE CARVING

Heisey's new type of decoration for glass and the Repeal of Prohibition resulted in the production of many new giftware items aimed at the now legally drinking public. It was now chic to have attractive glass bar accessories. The frosty look of Heisey's carved designs seemed tailor-made to decorate barware. Also the resulting silhouette-style designs lent themselves to a masculine style of interpretation - an advantage for barware. The hostess had her lovely glass tableware. The host was provided with sturdy, attractive drinking accessories.

Sweet Adeline (5002) is the most comic of the Heisey carved series. It features three very happy imbibers returning (?) from a night on the town. They are well-dressed - all sporting top hats, two still with cocktail glasses held aloft. In this imaginative caricature all appear to be singing lustily - singing "Sweet Adeline" no doubt. How well they could sing in their obvious condition is a matter of conjecture. The main portion of the glass surrounding the figures is frosted while the figures remain clear. An unusual cocktail shaker has been seen on which the 3 figures were etched and filled with a pale yellow-green enamel (almost iridescent).

Sweet Adeline was introduced in 1934 and had been discontinued by 1937, thus being scarce. It is found only on crystal with most items unmarked.

Found on:

- 500 OCTAGON ice tub
- 2052 bar
- 2401 sodas, old fashion
- 3405 ALIBI cocktail
- 3417 bitters bottle
- 4002 AQUA CALIENTE cocktail
- 4035 decanter
- 4225 COBEL cocktail shakers

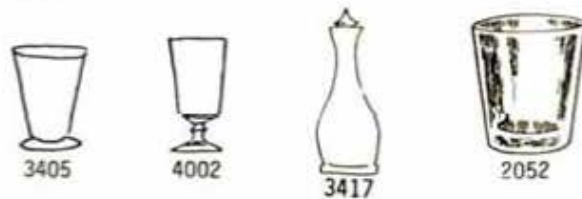

The following four carvings are quite interesting and were specifically made for bar bottles for various liquors. Unfortunately, catalogs and price lists only illustrate one design - the Rye. We had always felt that each liquor had its own design. While we still cannot illustrate all the designs for you, we can at least describe them all.

5004 Scotch Carving was the last I had to document. It is still known to me only by a description in an old trade journal article dated September, 1934, being "a highlander and his bagpipes."

5005 Bourbon carving proved to be what you might expect. A representation of a Kentucky Colonel, elegantly dressed, enjoying a glass of his favorite drink.

5006 Gin carving shows a portly black bartender or waiter. Here much of the design is left clear and the background frosted, but it is possible that the design could also be reversed.

5007 Rye Carving is the one known catalog illustration, showing a farmer with a 3 tined pitchfork.

All of these carvings are hard to find. They were new in 1934 and discontinued before 1937. All are found on the #4033 bar bottle. #5006 Gin has also been found on a #4044 New Era rye bottle, so it is possible that the others might be also.

#5007 RYE

#5002 SWEET ADELINE CARVING

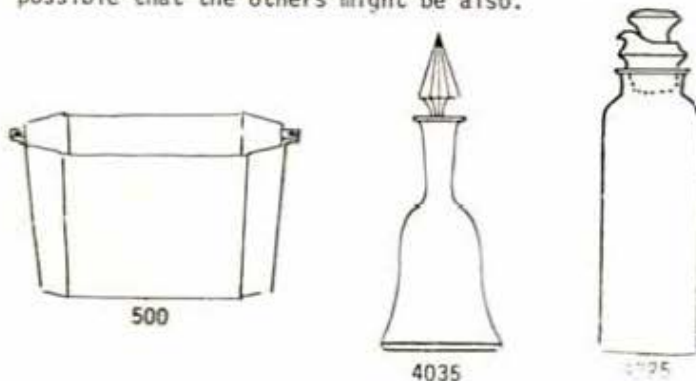

#9 HEAVY OCTAGON*

This is one of Heisey's earliest shakers. Heavy Octagon is not an original Heisey name but one I have chosen to give this shaker. It's shape is basically square (in fact at least one Heisey price list describes it as "square") with each corner having a rather large chamfer causing it's shape to become an octagon with four wide panels and four narrow panels. The glass is very thick in this shaker and it weighs much more than it appears to - hence "heavy" in the applied name.

This simple shape is not exclusive to Heisey. Just the opposite, in fact. The shape seems to be one of the many shapes of early glassware which was in the public domain. Many companies made this shaker, Fostoria and Duncan to name only two. It was also made by companies producing a lower grade of glass as I have seen some in lime glass containing many ripples and bubbles.

Heavy Octagon was made only in crystal and was made from circa 1900 to 1929. It was available with several different style metal tops and #1 and #3 sanitary tops.

When it comes to dimensions and description of the Heisey version of this shaker, I have some problems. I have two of these shakers in my collection - bought at different times - both from what I would consider "unimpeachable" sources. The first I cannot question as Heisey since it is marked on the inside bottom; the second was dug from the Heisey dump. It is not marked. Each shaker is of excellent quality glass with the possibility that the one from the dump is slightly better.

The following is a table comparing the two:

	Marked:	Unmarked (from dump):
Height:	3 1/16"	just under 3"
Width:	1 1/2"	1 7/16"
Base:	16 point indented star	12 point indented star
Quality:	Excellent	Excellent - more rounded on top of broad panels.

When I first compared these two, I felt that knowing the number of points on the base stars might help collectors distinguish Heisey shakers from those of other companies. However, I still believe both of these shakers to be Heisey, but the points on the stars vary in number. Even though the shaker from the dump is not marked, I feel it is of Heisey manufacture. The design of the shaker is so common I don't feel Heisey would have kept a competitor's shaker on hand for study. As a final note, the bases on the non-Heisey lime glass shakers I saw were plain (no star).

+++++

WHAT'S IN A NAME ? . .

By Neila Bredehoft

KIMBERLEY

A principal city of South Africa noted for its diamond mining.

It was founded in 1870. Originally there were three mines: one at Dutoitspan, one at DeBeers, and one at Colesberg Kopje. In 1873 the Colesberg Kopje mine was renamed the Kimberley in honor of John Wodehouse Kimberley who was the current secretary of state for the British colonies.

The DeBeers Group purchased the Kimberley mine in 1880 and thus controlled all production from the Kimberley fields.

Heisey used the name Kimberly for their 4091 stemware line which had a diamond motif at the base of the stem. It differs from Kohinoor in that it has a flared bowl while Kohinoor has a straight sided bowl. It was new in June, 1937.



No. 9 SALT OR PEPPER WITH NO. 42 TOP



1472 PARALLEL QUARTER Unknown Cutting

#8047 DAYTON

If you get a birthday greeting on Christmas day it's for one of two reasons. The first is that you were born on Christmas or, secondly, you were not born on Christmas but everybody celebrates your birthday then because your name is Jesus. I received a birthday greeting on Christmas day and I wasn't even born in December! It was a most humbling experience. I began bestowing blessings all around until my wife, Helen, brought me back to earth with one of my Christmas presents. A goblet (one of those covered in this month's column) was to be a birthday present and Bob Ryan, who used to be known as the "Heisey Hunter" but I like him anyway, knew this so he inserted a birthday greeting in the bowl. Then Helen, ever practical, decided that the leaf blower she had planned to give me for Christmas would make more sense for my October birthday so the gifts were switched. That's how my Christmas goblet came to say "Happy Birthday" and, since I've been deflated and no one seems to care anyway, I'll get on with the column.

No. 6010 Finesse was one of the last new designs to be distributed by Heisey and like most of the late offerings it was designed by Horace King. My weak memory has been telling me that I've covered Finesse already - if not on these pages then in "Another Club's Newsletter". Bear with me and I promise something new.

Finesse has a square stem which tapers slightly as it rises towards a bowl which is shaped almost like a hemisphere. At first glance the bowl seems to be too large for the stem. After studying the elements of the design for awhile you realize that though you definitely wouldn't want the bowl to be any bigger it would surely lose its character if it had been made smaller.

Finesse was not made in color and was never etched. The only choices for the buyer seem to have been plain or with either the 980 Moonglo or 1094 Ultronic cuttings and both look good on Finesse. A cordial, cocktail, claret, soda, sherbet, champagne, goblet, ice tea and wine were made and they are all hard to find. Finesse was never signed so you have to be particularly sharp if you hope to find it.

The goblet sketched life size here came out of a group of Heisey samples. The stem is identical to 6010 Finesse but the bowl, obviously, is different. Heisey has many lines which share stems but vary in their bowl shapes. Perhaps this was the intention here or it could quite possibly have been the loser when a decision had to be made as to which bowl would be used for Finesse. Either way it is fascinating and probably one of a kind. Let's call this one # Dayton.

Since this is our first stem column for the new year we are going to start things right by confessing that the risque story I've insisted was edited out of this column awhile back was really never in it. Louise is not sure that the readers of the Heisey News understand my sense of humor and she's probably right. With that out of the way we'll have to think of something else to keep the pot boiling in the future. In the meantime, before I was brought down to earth there was something I was going to do, I'll do it anyway. Bless you all.

Ed. Note: Bob Johnson also has a Dayton goblet and has had it on loan to the Museum for several months.

Since this whole page has been reduced approximately 15%, the goblet is shown that much less than full size.



6010 Finesse

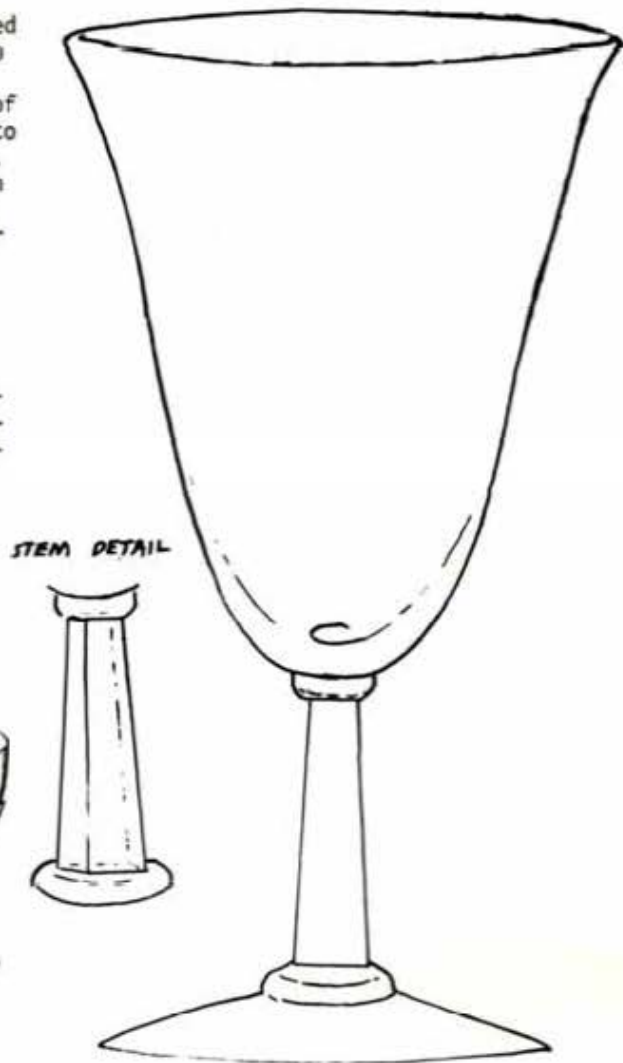

PUNCH CUPS IN THE #341 PATTERN

BY JOSEPH D. LOKAY

Let's first look at the names that were used with the 341 pattern. Items were produced under the number 341 from 1903 till the plant closed in 1957. In Heisey catalog 50, circa 1905, pattern 341 was named Puritan. This was the name assigned to the pattern by the Heisey Company. The name Puritan was dropped by the Heisey Company sometime around 1909. Price list 150, circa 1910, referred to pattern 341 as Colonial. The name Colonial continued till about 1937. Then the name Old Williamsburg was assigned to 341. This name continued till the plant closed in 1957.

There were five styles of punch cups in the 341 pattern. The five cups which are pictured with this article are:

- A. 3 oz., straight, pressed handle
- B. 4½ oz., straight, pressed handle
- C. 4 oz., flared, stuck handle
- D. 3 oz., tall, pressed handle (341½)
- E. 4½ oz., shallow, pressed handle

From here on, I will refer to the punch cups by one of the letters A through E corresponding to the above list. This should simplify discussion. Note that punch cup D was given pattern number 341½. I believe the ½ was used for ease of order form identification between the 3 oz. punch cup A (341) and the 3 oz. tall punch cup D (341½).

All five cups have ground bottoms, and all are signed with a diamond H on the inside bottom. I cannot say that the five cups always have typical Heisey stars in the bottom as I have a cup A with a star and a second one without a star. One may think that the star was ground away when the bottom was polished. This is not the case, as the cup without the star has a polished bottom rim. So far I have seen all five with a star and only the one style without a star. If you are a punch cup collector, what is your experience with stars in the bottoms of these five punch cups?

Price list 104, circa 2/15/1904, and catalog 50, circa 1905, are the first references to show the five punch cups. Therefore it is my estimate that production of the five cups started in about 1903.

Punch cup E has been identified by Heisey in two different ways. In catalog 50 (Vogel I, p 23), it is pictured with the handled custards with the sub title handled water ice shallow. In catalog 75, circa 2/1/13, it is pictured with the pressed handled custards with the sub title colonial shallow. Other catalogs refer to cup E as colonial, shallow. Thus, I included cup E in the punch cup category.

Production of the punch cups ended at various times. Based on examination of the catalogs and price lists available in the HCA Library, my estimates for when production ended are: Cup C in about 1915, cups D & E in about 1920 and cup A in about 1925. Punch cup B was still in production when the plant closed in 1957. Thus, the estimated production periods are: Cup A-22 years, Cup B-53 years, Cup C-12 years, and Cups D & E-17 years.

The five punch cups were made in crystal only. The references in the HCA Library showed no information to indicate otherwise.

Price list 142, circa 1908, lists punch cup C available with a #1 or #2 shaped handle. Since cup C was made using a stuck handle, different handle styles are possible. I could not find anything in the price list that described the shape of the two handles nor have I seen the two different handles on cup C. So, I can't define the two shapes at this time. Has anyone seen or detected two different shaped handles on cup C? The picture of cup C must show one style of handle. Price list 142 was the only reference that mentioned two shapes of handles.

Imperial made the Type B punch cups from 5-15-58 - 1-1-62.



No. 341-3 Oz.
COLONIAL

A



No. 341-4½ Oz.
COLONIAL

B



No. 341-4 Oz.
COLONIAL

C



No. 341½-3 Oz.
COLONIAL

D



No. 341-4½ Oz.
COLONIAL SHALLOW

E

From the Newark ADVOCATE, Newark, O., Thursday, January 1, 1981...

"WILL ANDERSON CELEBRATES 105TH BIRTHDAY

BY GLORIA C. HOOVER

Will Anderson, rejected by the army in 1898 because he had varicose veins and told by his wife to quit smoking in 1970 because it wasn't good for his health, is celebrating his 105th birthday today.

Though Will walked all of his life - he never owned an automobile - he now spends most of his time in a wheelchair at LPN Health Care Facility on Price Road.

His hearing is impaired and eyesight failing, but age hasn't dimmed his appetite.

"He still loves sweets and eats very well," Meg Nabors, director of nursing, said.

And she added that his family is "very good to him."

Will's family - his son, Willis, granddaughter, Patricia Deardurff, her husband, John and son, Matthew, age 9 - agree that Will is a special person.

Patricia said she has fond memories of the companionship Will gave her when she lived with him and her grandmother.

"My grandfather walked me everywhere - to the Pennsylvania station to meet trains, shopping and the movies. He'd take me to the courthouse square where I'd roller skate or ride my tri-cycle."

Patricia said she remembers her grandmother, Will's wife, as a hard-working woman who had a flair for life and cooked everything in heavy fat.

But the high cholesterol diet must have agreed with Will. Last year on his 104th birthday, a visitor said to him, "You'll probably live to be 200."

Will replied, "I'd like that."

Photo Caption: "Meg Nabors talks to Will Anderson who celebrates his 105th birthday today. Mrs. Nabors, director of nursing at LPN Health Care Facility, Price Road, sees Will at least once each day. "He's a very enjoyable man and still very amazing" she said. Will is also the oldest living retired employee of the Heisey Company. A fourth-generation glass worker, Will began at Heisey in 1902 and retired in 1948 at age 72."

* * * * *

Ed. Note: HCA honored Mr. Anderson with a reception in the Museum on the occasion of his 100th birthday on Jan. 1, 1976. He was in relatively good health at the time and was living alone, but shortly afterward he went to the health care facility where he still lives today. He is one of the gentlest and sweetest persons one could hope to meet and everyone who knows him speaks of him with affection. We sent him a card and a basket of fruit for his birthday. L. R. See HEISEY NEWS, January, 1976, p. 10 for a picture of Mr. Anderson.

+++++

DID YOU KNOW THAT . . . BY LOUISE REAM

The cutting shown on a plate in Vogel's 1979 summer issue was called Crysanthemum by him. He said that 679 has no name. It was named 679 WINDSOR by Heisey and so listed in catalogs. Much of this pattern was cut through the years on Heisey and other glass.

1295 BEAD SWAG - We have a listing for the 2" rose bowl which was probably made from the toothpick mold. The lamps in this pattern are made from the little molasses jug by putting a kerosene lamp burner instead of the usual top. The same thing has been made from molasses jugs of other patterns. The Museum has the rose bowl in opal and the lamp in crystal.

The 1183 REVERE candlestick and the 1511 TOUJOURS candle vase are the same with the exception of the top rim.

Thousands of 337½ goblets and sherbets were made in Harvey Amber in 1948. Where are they now? They were made by J. Maurer, W. Reinbeau and H Loughman.

William Hartman and William Fairall, G. Hartman and H. Foreman made most of the animals being made in 1948-49. W. Lavelle and Mr. Klein made the 1 HORSEHEADS during 1948.

F. Gamble made hundreds of 1536 MILITARY CAP ash trays in 1948.

In 1948 and 1949 Authur Kessmier was making hundreds of puff boxes for Hope Glass Co. There is no way to identify these boxes at this time. Heisey made many puff boxes for this company.

Did you know that the 353 Medium Flat Panel vase was actually made in Hawthorne?

REPRINTED FROM "DIAMOND DUST" (ANOTHER CLUB'S NEWSLETTER)

" DAVE CURLEY . . . 007½

It was traumatic, a choice had to be made, an exciting James Bond movie had just eased into its thundering finale as the program "Antiques" began on Public Broadcasting's Channel 21. Normally there'd be no problem. Just stick with the picture in which you've already invested an hour and forty-five minutes. But things were different this time. "Antiques" listed "Heisey Glass" as its subject and with the vagaries of PBS scheduling, who knew when we'd ever see it offered again. So it was goodbye James Bond and hello Heisey.

How Dave Curley, that dedicated Heisey booster from Albany, New York, is no James Bond. But as guest expert on "Antiques" he certainly rivaled 007's aplomb. George Michael, the show's weekly host, is far from a Bikini-clad Bondian helpmate but he too functioned in exemplary fashion. After a brief but very interesting discussion of Heisey history, Dave took a chronological path through the Heisey patterns, colors and decorations. The first piece presented was a Fandango rose bowl. It showed up all glittery and magnificent on our cable-fed TV screen. This was followed by other unsigned pieces in the early patterns and colors. The first marked piece was a brilliant Peerless compote which was followed by a soap dish, hair receiver and a beautifully cut 3-light candelabra.

There was some very informative give and take on Heisey and Sandwich glass and those patterns that Heisey "adapted" from that pioneer manufacturer. (W. Boland would have flipped over the dolphin candlestick). Dave also charted a course through all of Heisey's production colors which gave him the opportunity to show off some very fine examples. The more popular etchings like Rose and Orchid were shown and even the rare and unusual, such as Heisey/Verlys, a frosted Grape Leaf plate and an Amber and Zircon cane whimsey, came in for some intelligent discussion. The program closed on a very attractive necklace made from the handle of a Zircon Fern dish.

It was an excellent show, one that could make the advanced collector swell with pride and bolster the novice's enthusiasm. But more important it let the uninitiated know what our great glass collectible is all about. Hopefully, the program will make a lot of converts and that, dear reader, will benefit all of us.

Thanks, Dave, I may never learn how 007 thwarted the villains but you proved to be an even more enjoyable substitute.

- Vince Sparacio "

+++++



ORIGINAL "FLAMINGO" LABEL . . .

The label appears to be 1" tall by ½" wide. Gold color, pink flamingo, black lettering.

This is a good drawing of the original Flamingo sticker used by the Heisey Company on much of its Flamingo colored glassware during the late '20's. These are sometimes found today but not often.

This drawing was sent to us by a member.

We have at least 2 pieces with this label in the Museum.



Thought you would like to see this. This sign was taken from the "Ladies Rest Room" out of the old Heisey Factory. (So I was told by the woman who had it. Came from a friend of hers who worked there.) Has some names & phone numbers on it.

- D. B., N. Carolina

DOWN THE HEISEY TRAIL

BY JIM JORDAN

Happy New Year! Here we are going into our tenth year and Heisey is not only still sought after and craved, but is showing signs of unabated frenetic popularity as a collectible. The grabbing, devious maneuvering, and occasional stampeding at flea markets and shows for that elusive "one of a kind - unseen - ultra rare" gem is still occurring at an unrelenting pace. Case in point -- that Wicked Witch of Chester, PA recently waved her wand at a local auction and immobilized all bidders for a pair of #112 candlesticks. Why, you ask, would anyone go to such extremes over a lousy pair of #112 sticks? Well, first of all, no Heisey is lousy, and especially not these sticks!! They are the most gorgeous alexandrite color I have ever seen - bar none!!

Rumors (actually grumbling) are still coming through the lines about the Bay State Club. Seems they're doing more than sitting around drinking tea and plotting ways to get the Indians in trouble. (Beware, this here writer's grandma was a Cherokee.) Mr. Lloyd and Mz. Janet found a 6" pickle boat (pickle boat??) in #473 Narrow Flute with Rim in - flamingo - a Victorian champagne in sahara (grumble, grumble) a Plantation sandwich plate, and another 6" pickle in #365 Old Queen Ann. Nice goin' New Englanders.

This next report should strike right to the heart of every Heisey collector. Seems this guy from South Jersey was watching an old movie on television aptly named "Never Give A Sucker An Even Break" (Love it) and spots a pair of Heisey Horse Head Bookends. Seeing that Heisey and keeping the movie title in mind, this couple (hereafter coined as "Even Break") go out the next day and "steal" a sugar bowl in - vaseline - 6 #350 Pinwheel & Fan punch cups in moongleam, and 6 more in Old Queen Ann. Those old movies get the adrenalin pumping. THE candlestick boys from Virginia were at it again. (If you can't guess who they are, I hope you land on either Boardwalk or Park Place). Their latest additions are - a pair of #105 5" candelabra - read and weep - a Petticoat Dolphin in moongleam (super) and a pair of #116 Oakleaf sticks in (O-migosh!) hawthorne. Breaking stride, they stopped long enough to liberate a #3480 pitcher in - what else - hawthorne, checker optic. These guys are dangerous.

Hey, those ding dong Donovans are up to their old tricks again. Seems they found a #133 Swan bowl, a pair of Dolphin footed candlesticks and bowl in sahara, and an 11" cut basket. These are all great finds but they didn't steal em, and petrol costing what it does, it takes a big bite out of the ol left rear pocket, dontcha know. Little Big Man (Art Hartman's protegee) from Newark, Ohio (Thats some little town somewhere between Pittsburgh and WKRP) has been findin some REAL winners folks. Hang on, here we go. A Gascony goblet in Dawn, a #21 electro portable lamp in Flamingo (I'm gonna be sick) a #3359 rose bowl in flamingo and - a #338 vase in - moongleam. This guy's getting dangerous too.

Hey, remember those #4206 Optic Tooth sodas in hawthorne-moongleam reported some time back. Well, where there's tumblers, you expect to find a pitcher, right? Well, expecting is over. Seems some guy that lives less than a mile from me found one. I honestly don't know who this guy is, I just keep hearing about him. I've gotten to calling him The Phantom. Phantom, if you're reading this here column, show yourself man so I can get a bead on ya.

To "Mom" Belber in Florida: Keep on truckin, and keep Arty away from those cookies. Love ya all, and see ya down the trail.

+++++

THE NATIONAL CAPITAL HEISEY COLLECTORS CLUB
Presents the Ninth Annual
"ALL-HEISEY GLASS SHOW AND SALE"
For the benefit of the HEISEY MUSEUM

Sat, Mar 21, 1981 11 AM to 9 PM	Sun, Mar 22, 1981 11 AM to 5 PM
HOLIDAY INN (One block from Washington Beltway)	Alexandria, Virginia (Use Telegraph Road Exit 2N)
FREE DOOR PRIZE Admission \$2.00	FREE DOOR PRIZE With This Ad \$1.75

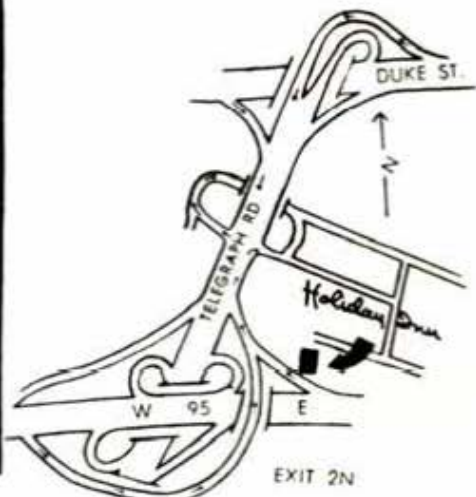

You may Xerox this ad in order to get your 25¢ discount.

CLUB NEWS

LAND OF HEISEY SOCIETY

The Land of Heisey Society Study Club will meet at the National Heisey Museum March 4, 1981 at 7:30 pm. Anyone interested in learning about Heisey glass is invited to attend. The study club is open for new members. A brief outline of the Club's activities will be discussed, prospective members questions will be answered. Circle March 4 on your calendar.

-Vera Bagent, membership

- - - - -

GATEWAY HEISEY CLUB OF PITTSBURGH, PA

On the beautiful clear evening of December 6, 1980, members of the Gateway Heisey Club traveled from near and far to the home of Rick and Mary Alice Stoll for the December meeting. Delicious and "fattening" goodies were served by Mary Alice.

Our President, Carlene Masson conducted her last business meeting of the year. At the end of the meeting she turned the presidency over to Laverne Lokay. Since we believe in Women's Lib, all our new officers are women. Edie Van Dyke is vice president; Phyllis Freier is secretary; Phyllis Goldstein is treasurer.

Laverne Lokay, our president for 1981, announced the new chair persons. Bob Cook is Program chairman. Hobie and Frances Chivers are in charge of social activities. Margaret Reed will keep us in the public's eye with publicity. Edie Van Dyke and Harry Freier will help our financial status as Ways & Means chairpersons.

Sally Mohlford joined our club - bringing our membership to 18.

Our thoughts and best wishes go to Meredith Hogner, who is recovering from surgery.

Charles Van Dyke increased our knowledge of Heisey with his program on Rococo and Normandie etch. He showed several examples including a Rococo footed tumbler, Rococo candlesticks and a 5 piece Buttress pattern centerpiece with the Normandie Etch.

Many Heisey "goodies" were shown at the "Show & Tell" portion of the evening - a Spanish stem goblet with a "Nail-like" cutting, and a dawn Lodestar ash tray were the finds of the evening.

The meeting was adjourned with the wish of Happy Holidays and a Prosperous New Year for everyone. The next meeting will be the 1st Saturday in February at Bob Cook's.

- Phyllis Freier

- - - - -

DOOR KNOBS BY HEISEY

- NEILA BREDEHOFT

Recently while doing other research in the old turn ledgers now belonging to HCA, I kept finding numbers for doorknobs. It has been known for many years that Heisey made knobs but I was fascinated by the apparently large numbers in which they were produced and also the apparent variety.

Unfortunately, we can't show you pictures of these knobs - we do not have any and we would have no way of matching the numbers found with the correct style of knob anyway. If you are able to visit the Museum, a great many of these knobs are on display in the lower level. Several styles are also pictured in Viola Cudd's book "Heisey Glassware."

For of whatever interest it may be, the following numbers were used by the Heisey Co. from as early as 1911 to as late as 1946 for doorknobs.

No.	Size	No. in Move
1	2 1/2"	650
2	2 1/2"	650
3	2 1/2"	650
4	2 1/2"	650
5	2 1/2"	650
6		
10	1 1/2"	900
11	2 1/2"	600
13	2 1/2"	600
13 1/2	2 1/2"	600
14	1 3/4"	850
15	1 3/4"	675
16	1 1/2"	900
42	1 1/2"	900
43	2 1/2"	650
50	2 1/2"	650
59 *	2 1/2"	
253	1 3/4"	850
352		
353		
502		
507*	2"	
510	1 1/4"	950
512		
602	1 3/4"	850
612	1 3/4"	850
642	1 3/4"	850
715	1 1/2"	845
716	1 1/2"	810
717	1 3/4"	810
718	2 1/2"	650
2011		
2018	2 1/2"	650
2052	2 3/4"	550

* Possibly done as a special order or an outside job.

Most dimensions were found in a list probably used for repricing dated 1/1/38. Other dates on the page were 1945 and 1946.

LETTERS, WE GET LETTERS , , ,

I have been an avid Heisey collector since I bought my first piece in 1962. I am an active member of the Heisey club and enjoy receiving the newsletter and the information it provides. Your staff does an excellent job of publishing. My purpose for writing is to enquire as to whether the Heisey Museum would be interested in becoming the beneficiary of my collection. I am in the process of drawing up a new will and would like to see my collection kept together as a collection. I feel my efforts should benefit someone besides myself and know Heisey enthusiasts would enjoy the opportunity to see these pieces in our Museum.

- L. S., Ohio

President's Note: How wonderful this is! We hope that other people feel this way as well. If so the Museum's future is assured.

+ + + + +

The Heisey News is "tops". I can hardly wait for the next issue. You are doing an excellent job. There is so much to be learned (if I could remember it all) from each issue.

I get positively ill when I think of the questionable pieces I have passed up.

- V. Adams, MO

+ + + + +

Words can't express my feelings for our vacation in Heiseyland during the cordial dinner. The people who had a part in the gala affair can surely stand tall - the food, the entertainment and most of all the wonderful people, combined made a trip Frantz and I will long remember.

It was also a thrill to have a part in breaking the cordials with flaws - if breaking a piece of glass Heisey or otherwise can be a thrill, anyway everyone was great and wonderful - and I truly hope Lord willing it will happen to us again.

- Frantz & Maxine Hertrick, CA

+ + + + +

HCA has to be the best bargain in the US!

- J. Gillette, NY

+ + + + +

Renewal for the 4 Parkers for 1981-members since the start-wouldn't have missed it.

Ten years of Heisey hunting has not dimmed our enthusiasm. It's as exciting and challenging today as it was in the beginning.

Your competence and dedication have served us well and you have our gratitude.

- Bob Parker, CA

QUESTIONS AND ANSWERS , , ,

Q. Did Heisey make napkin rings?

A. No, Heisey did not make any napkin rings. You often see the glass ferrule for lamps being offered as a napkin ring.

Q. Did Heisey make two color glassware which gradually blend?

A. No, Heisey made very few items in combinations of two colors and they didn't gradually blend.

Q. What is meant by "ground bottom"?

A. "Ground" is done by grinding wheels which cut the surface very flat and smooth. This made the glass gray. Polishing restored the shiny surface. "Polishing" was done by hand, usually with cork wheels. Glass "fire polished" was put back into the "glory hole", a very hot flame, which melted off mold marks and other roughness. Often bottom rims, or entire bottoms were "ground", then polished to make them shiny again. A "punky" is usually an oval indentation (or possibly a round one) such as on Punky Band or Old Sandwich. (A punkied bottom is usually a polished indentation such as on the bottom of a blown pitcher or on candlesticks.) On a pitcher the punky kept the pitcher from sticking to the table when damp.

HCA CHRISTMAS DINNER 1980

Season's greetings once again -
Peace on earth, Goodwill to men
I've done this now for many years
But I am practically in tears

Because I've nothing else to write.
Now you can understand my plight,
I've extolled Santa and his elves,
I've talked of Heisey on your shelves;

Suggested gifts of cobalt blue
And animals (all Heisey) too.
Of using Heisey for decor
And urging you to buy some more.

There's not a nicer sight to see
Than Alexandrite 'neath your tree.
Or punch bowl filled with Christmas cheer
For those of you who don't like beer.

A lovely piece of Tangerine
Sent by an aunt, or some Marine
I could go on ad infinitum
And mention item after item,

But you have heard all this before
And I don't want to be a bore.
I finally got these verses done
So MERRY CHRISTMAS everyone!

- Liz

TIPS FOR MAIL BIDDERS - MARCH AUCTION

BY BOB JOHNSON

With the approach of March and the Annual Auction, it's time again to review the procedures for mail bids. Although primarily aimed at the first-time bidder, this can also be a refresher course for the "repeaters" (present company NOT excepted)! With the use of mail bids we are able to extend the opportunity to participate in the Auction to all members, whether or not they are able to attend. A review of auction results the last few years shows that mail bids have won on a significant number of items, so you DO have a good chance.

Each mail bid is handled competitively; that is, we start at a reasonable level and bid only as high as necessary to buy the item or lot. Of course, each bid has to have a limit - set by you, the bidder - and we can't bid above that limit. Sometimes, due to the sequence of bidding, a competing bidder will hit the exact amount of the limit and win the bid. This is always frustrating, but an unavoidable part of the game!

To anyone who would like to submit one or more mail bids for the coming March Auction, we would like to suggest the following tips:

1. Lots containing multiple items (such as cream and sugar, set of goblets, pair of anything, console sets, etc.) are usually sold as "so much a piece, the set (pair, lot, etc.) to go". Therefore the final lot price will be a dollar multiple of the number of items in the lot, and a bid limit should be set accordingly. (example: a pair of candlesticks at \$20.00 each make a lot price of \$40.00).
2. There are minimum limits to raises that will be accepted in the bidding, depending on the price level of the item. These limits range from \$1.00 possible on an item under \$10.00 to \$25.00 or higher on items over \$100. Therefore a limit of \$10.25 is no better than one of \$10.00.
3. Multiple item lots are not normally split up, but sold as a lot to one bidder.
4. A separate check may be sent for each lot to be bid, or one check may be enclosed for the total of the maximum bids for several lots, but in either case, include a sufficient amount for shipping. Be sure to stipulate how much is the maximum bid for each lot and how much is for shipping. Any surplus from the bidding and/or shipping will be refunded.
5. Since HCA can accept BancAmericard/Visa or Mastercharge, we'll try something new this year. If you have either card, you may just send a list of maximum limits for each lot you wish to bid for, along with your card type, number, and expiration date. Then the total cost, including shipping can be charged to your account.
6. An "SASE" is requested to return unused funds and your letter giving the results of your bids.
7. The glass for all successful mail bids will be packed and shipped by UPS from the Administration Building. Therefore a complete street address is required. (No P. O. Box addresses, please).

Due to the large volume of mail bids, we will be unable to comply with special requests, such as calls to give results.

Only mint items will be bid on - if damage is noted on an item before it is put up for auction, we will not bid on it. However, if any mail bids are received for items noted with an "X" in the original list as imperfect, we will bid on an "as is" basis.

In case of duplicate mail bids, the one with the earliest postmark will be given preference. All mail bids must be received by Thursday, March 12, at the following address in order to be prepared for the Auction:

HCA Auction
PO Box 42
Dayton, OH 45420

If you have any questions, you may call me at (513) 299-4364 evenings or weekends (NOT collect!)

DATES TO REMEMBER . . .

- | | |
|-------------|--|
| MARCH 13-14 | EIGHTH ANNUAL ALL-HEISEY BENEFIT AUCTION, OSU NEWARK
CAMPUS, COUNTRY CLUB DRIVE |
| MARCH 15 | FLEA MARKET, STARLIGHT SCHOOL 9 AM - 4 PM |
| MARCH 21-22 | NATIONAL CAPITAL HEISEY COLLECTORS ALL-HEISEY SHOW
& SALE |
| JUNE 18-21 | TENTH ANNUAL CONVENTION, NEWARK, OH |

The following is reprinted from The Columbus Dispatch

"A LOG CABIN WITH A PAST AND A FUTURE"

BY GORDON KUSTER

"Everything in the realm of objects with age, from the old-time, home-fashioned meat block to the highly-polished and impressive highboys, have interested Wilson Heisey for the past 30 years. In that time he has acquired probably the most comprehensive collection in central Ohio.

Scarcely an object used in the past 100 years but that it has found its way into his possession. Even vehicles that have long since passed from existence or utility are among his souvenirs of the past.

And the motivation for collecting he has found in a desire to preserve these objects so that future generations might not lose sight of the fine old things which pioneer Americans used in fighting the frontier and conquering new lands for the present generation to enjoy.

That's what makes Mr. Heisey's collection so interesting. He is head of the Heisey Glass Co., at Newark, and one entire portion of the factory is devoted as storage space for his old vehicles and other antiques, which are not yet restored to their original utility. However, thousands of them have been restored.

To see the results of his untiring efforts to preserve America's past history in the form of these old vehicles, implements and household furnishings is a revelation even to one accustomed to visiting museums and the homes of antique collectors.

Among Mr. Heisey's acquisitions, the old vehicles are perhaps the most unusual, although the scores of various kinds of stirrups, saddles, oxen yoke and harness all appreciably to its value. (sic)

As a suitable setting for his antique furnishings, he also reverted to the past. He scoured the countryside and finally purchased seven log cabins, representing more than 700 years in age. These he dismantled and transported to a beautifully wooded site about 15 miles east of Newark and a mile north of Route No. 16, where huge boulders are jutting out of the grassy hillside to form a picturesque background for the "composite" cabin.

Taking the road to Baughman park, heading north from Route No. 16, the motorist climbs a steep hill and at the top finds the Baughman park road cutting back to the right. At the left is a lane which leads to the Heisey cabin. It is located on a level spot in the hillside, the front porch overlooking a magnificent view of the rolling countryside and the back, a spacious and well-kept yard with benches and jars and two dog houses made from huge hollowed-out stumps set endwise and with the door scrolled out of the side. In the back also, and at the right of the lane entering the grounds, is a spring flowing from the natural rock. Here Mr. Heisey has built a protecting arch for this spring and a rock wall and stepping stones leading to it.

The main cabin required two years for building. Stones for the terraces were taken from the old canal locks at Trinway.

There also is another cabin, a smaller one, located farther up the hillside. The larger one is used by Mr. Heisey for a country home and for entertaining guests and the smaller one for additional sleeping quarters and smaller parties.

There are five large fireplaces in the main cabin, two upstairs and three down, the one in the downstairs living room being extra large. On either side of it are double Dutch ovens and on all five are sufficient antique ladles and other kitchen utensils of the bygone ages to cook an ample meal for a large number of guests.

A novel feature of the cabin is the treatment of the lights. In each room, electric lights have been wired into the center of the loops in oxen yokes and the entire yoke suspended from the ceiling.

One of the most unusual pieces in Mr. Heisey's possession is a solid iron sea chest which is in the upstairs hall. The lid remains open, revealing the intricate mechanism of 13 different locks, all of which are operated by a huge key fitting into the keyhole secluded by a false covering. Built about 1700, the chest was purchased by Mr. Heisey in Baltimore.

In this same hall is his collections of stirrups numbering nearly 100. Doors from this hallway lead to two bedrooms, one at the west, equipped with a fireplace, and the master bedroom at the south. To the east is the upstairs living room and in the east wing a dormitory with a half-dozen four-poster double beds, each with its antique quilt.

The upstairs living room is equipped with settee before the fireplace, a reading table, 12-der back chairs, old time rockers, spinning wheel and hooked rugs - a cozy place for an afternoon with your favorite book or magazine.

The beamed ceiling in the downstairs living room adds an intriguing touch to the general atmosphere. Beside the fireplace are two large candle moulds and on top of the mantle reposes an old coffee grinder, numerous pewter pieces and earthenware.

The dining room is located at the east end downstairs and at the west end is a den, or writing room, furnished with antique desks and an unusual type of bookkeeper's stool used a century ago.

The stairway to the second floor in the cabin is made of solid hewn logs, while the stairway to the cool basement is made of stones.

(continued)

"The cabin itself is a veritable museum, containing as it does, samples of early American life in such an array it dazzles the visitor. Antiques run the full gamut of types, including Sheraton, Chippendale, Duncan-Phyfe, Hepplewhite, early American and others. Pictures, also are antique and give a touch of quaintness which has a distinct allure.

Such is the cabin which is visited weekly by numerous persons who have heard of Mr. Heisey's collection and have come perhaps a thousand miles to see it.

At his factory in Newark, Mr. Heisey has a window taken from an old post office. It shows a pony express rider etched in the glass.

"I found it in Elizabethtown, Ky., in a saloon operated by a man known as 'Jake,'" Mr. Heisey told me. "They claim that Jake was the only man who ever socked Carrie Nation when she was crusading against saloons. She came in to tear his up and he hit her squarely on the jaw."

Another piece in his collection is a stove from the old Marianne furnace east of Newark, one of the few remaining ones turned out by his establishment.

Everything with age and history behind it interests Mr. Heisey. He has traveled extensively and is always on the alert for objects of value. He explains his hobby with a convincing argument:

"There have to be so many people," he said, "who are jackasses. If we didn't have them, then we wouldn't have any pure-bred horses, or cattle or any of the original strains preserved. It's the same with these things (pointing to his collection) if someone didn't save them, they'd be destroyed and no one in the future would have them."

Following this principle, his collection stands as a rare exemplification of one man's devotion to a purpose.



WHAT'S IN A NAME ?

481 LANCASTER

Lancaster Silhouette Etching was named for the Heisey's horse trainer - William Lancaster Smith, who was always known as Willie Lancaster. He did not work exclusively for the Heisey's, but did come to Newark to train their horses.

463 EQUESTRIAN

This Etching featured one of the Heisey horses, Rexanna H. Peavine.

From the Crockery & Glass Journal
May, 1932:

"Heisey Horse Wins Top
Honors

Rexanna H. Peavine, the bay mare owned by T. Clarence Heisey, president of A. H. Heisey & Co., Newark, O., scored an upset at the Atlantic City Horse Show April 16 when she walked off with the \$1,000 championship stake under the nose of Rhododendron, long the reigning eastern queen. A sensation was created in the presence of 14,000 spectators when Rex Peavine was crowned queen in the five-gaited saddle horse grouping and her rival went down to defeat. The mare is eight years old, stands 15.2 hands and the show was her first. "



481 LANCASTER



463 EQUESTRIAN

A. H. HEISEY & CO.

NEWARK, OHIO.

No. 1225 WARE.

Heisey's Third Pattern

First Ad, Jan. 16, 1897



REPRESENTATIVES.

West, W. B. Lindsay.

East A. A. Graeger. New Eng and and Penna. Jos. Tomkinson. New York Office, Marter & Parmelee.
Baltimore Office, Green & Seaman, Pacific Coast, C. D. Helwig.

Bob & Fran's
ANTIQUES
 2007 Broadway
 VANCOUVER, WASHINGTON 98663

We Specialize in
Glass — China
Silver Flatware
Collectibles — Furniture

HEISEY — Rib & Panel (Clear)
 — 115-Piece Unit Sale —
For complete list, send us self-addressed stamped envelope.
We invite you to come in and browse

MONDAY—SATURDAY—10 a.m. to 5 p.m.
2007 Broadway—(206) 693-7972
 — *We Like to Buy Old Things* —

H & R DIAMOND H
Helen - Bob Rarey
1450 White Ash Drive
Columbus, OH 43204
(614)279-0390 after 5:30

- + 134 TRIDENT 2 lite w/497 ROSALIE etch...\$ 22.50
- + 339 CONTINENTAL ftd. egg cup *..(2)..ea. 10.00
- + 351 PRISCILLA 13" relish * 20.00
- + 352 FLAT PANEL hotel cream & sugar *... 30.00
- + 406 COARSE RIB finger bowl & 4" plate *. 22.50
- + 1055 ASTOR 7½ oz. Hiball*, NO..... 22.50
- + 451 CROSS LINED FLUTE vase *..... 32.50
- + 1184 YEOMAN cream & sugar * cut..... 50.00
- + 1229 OCTAGON 5" may. w/ cutting..... 27.50
- + 1255 PINEAPPLE & FAN 4½" nappy (4)...ea. 12.50
- + 1255 PINEAPPLE & FAN 12" oval bowl..... 32.50
- + 1405 IPSWICH 10 oz. soda..... 10.00
- + 1509 QUEEN ANN 12" hld. sand. plate*..... 30.00
- + 1511 TOUJOURS 12" relish*, cut..... 20.00
- + 4220 Spiral Optic 6" vase..... 27.50
- + 4045 Ball Vase, 6" Saturn Optic..... 27.50
- + 5019 WAVERLY ice tea *, ftd. 13 oz.
 (7).....ea. 12.50
- + 5089 COMET soda, monogram SJS..... 27.50

... * Signed
 ... SASE Please
 ... Shipping & Insurance Extra

13th Annual Antiques Show and Sale

Sponsored by
Beta Sigma Phi Sorority of Reynoldsburg, Ohio
 Saturday, March 7, 1981 11 a.m. - 9 p.m.
 Sunday, March 8, 1981 12 Noon - 6 p.m.

Arts and Crafts Building—Ohio State Fairgrounds
 Exit 17th Ave. I-71 Columbus, Ohio

Show Chairman
 Mrs. Murray Youtz
 1519 Leedale Drive
 Reynoldsburg, Ohio 43068

Show Manager
 George Hoffman
 129 S. Fourth Street
 Newark, Ohio

*Benefit: Truro Township Fire Dept.
 Pickerington Police Department*

Donation: \$1.50



Classified Ads

- + - FOR SALE: One 341 Puritan nappy \$35;
- + #150 Banded Flute nappy (two chips on
- + base) \$25; PAT OLSEN, Star Route 3, Box
- + 10980, Dos Rios, CA 95429.
- + - WANTED: Tops for one pound Recessed
- + Panel candy jars-two in crystal, one
- + alexandrite. Two saucers Empress,
- + Crystolite. F. H. HILLEBRAND, 12 Illi-
- + nois, Pontiac Mich 48053 Phone 1-313-
- + 332-0838.
- + - WANTED: Buying Depression Glass,
- + Heisey, Cambridge, Fostoria, Akro Agate,
- + glass figurals & unusual glass "cuties".
- + NADINE PANKOW, 207 S. Oakwood, Willow
- + Springs, ILL 60480. Phone 312-839-
- + 5231.
- + - WANTED: Heisey baskets and punch
- + bowls. DAVID JORDAN, Box 387, North
- + Salem, IND 46165



VIRGINIA & ODELL JOHNSON +
 GLASS 'N' GLASS +
 6909 - 10TH AVE. WEST +
 BRADENTON, FL 33529 +
 PHONE 813-792-0604 * MARKED +

POSTAGE & HANDLING EXTRA

462 NAIL 8" nappy*(rare).....\$ 50.00 +
 RIDGELEIGH REIS blown goblet MARIEMONT
 cut (1)..... 50.00 +
 RIDGELEIGH REIS blown champagne MARIE-
 MONT cut (1)..... 35.00 +
 3380 OLD DOMINION champagnes, EMPRESS
 etch (4" stem) 7 ea 12.00 +
 3380 OLD DOMINION goblets EMPRESS etch
 6-8", 3-8 1/2" *.....ea. 14.00 +
 1469 RIDGELEIGH 8 1/2" plate, 6 1/2" plate,
 c/s * each place set..... 25.00 +
 1469 RIDGELEIGH 8" vase SAHARA *..... 80.00 +
 1469 RIDGELEIGH 8" vase ZIRCON* - mini-
 ute chip at bottom..... 50.00 +
 1509 QUEEN ANN mustard..... 20.00 +
 1401 EMPRESS 7" candlestick (135).pr.. 70.00 +
 29 candlesticks 7" *.....pr.. 65.00 +
 32 candlesticks 5" *.....pr.. 45.00 +
 1488 KOHINOOR 2 lt. candlesticks.pr.. 60.00 +
 1428 WARWICK 1 lt. candle, *.....pr.. 40.00 +
 4044 NEW ERA cocktails, COBALT bowl(3) 95.00 +
 4044 NEW ERA champ. COBALT bowl (6) ea 60.00 +
 1428 WARWICK 1 lt. candle * SAHARA..pr 50.00 +
 473 NARROW FL W/ RIM stack cr/sug *
 (no butter)..... 25.00 +
 300 PEERLESS indiv. cream/sugar *.... 22.00 +
 393 NARROW FLUTE indiv cream/sugar*.. 22.00 +

HAVE YOUR HEISEY NEWS
 PERMANENTLY BOUND . . .

BLUE HARD COVERS WITH GOLD EMBOSING
 Binding \$10.00 per volume, plus \$1.50 post-
 age and insurance.

Volume I, HEISEY NEWS 1972-74
 Volume II, HEISEY NEWS 1975-76
 Volume III, HEISEY NEWS 1977-78
 Volume IV, HEISEY NEWS 1979-80

BROWN HARD COVERS WITH GOLD EMBOSING
 Vogel's Newscasters (1971-76) - (1977-78)
 (1979-80)
 Binding costs same as HEISEY NEWS per
 volume.

Bind all FOUR of Vogel's Heisey Books into
 ONE Brown Hard Cover Volume - \$12.00 plus
 \$1.50 postage & insurance

Mail YOUR Material for Binding to:
 CLIFF HARRALSON, COM. CTR.
 Northeastern Illinois University
 5500 N. St. Louis Ave.
 Chicago, Ill. 60625 UPS is OK

+++++

614-873-5622

PLAIN CITY AUCTION
 145 E. MAIN ST.
 PLAIN CITY, OHIO

614-876-5207

FRIDAY NIGHT FEBRUARY 27TH 5:00 PM
 APPROXIMATELY 12 MILES NW OF COLUMBUS, OHIO

Included in this large and interesting sale will be over 100 pieces of Heisey several of which are unusual and hard to find items. Tangerine cane made for the Labor Day Parade of the early '30's; Deep Plate Etching including 2 Tally Ho 10 oz. tumblers, 5-12 oz. beer mugs - Tally Ho, Equestrian, Fox Chase, Sportsman, Club Drinking Scene, all marked. Fox Chase 1 qt. cocktail shaker and 6 matching cocktails; Plantation covered compote ftd. H, also cruet; Antarctic including covered candy dish d. f., cream & sugar, d. f.; Orchid Waverly cigarette holder & cover H; Flamingo 2 pc. duck flower block; Twist Sesquicentennial platter; Pied Piper tankard with cut neck, 12 wines H, 6 saucer champagnes H, 8 goblets H; Ivorina Verde Winged Scroll 4 1/2" nappy; pair Queen Ann etched candelabra w/A prisms; Cut 11" floral bowl w/ matching #142 candlesticks; Goose stem cordial; Victorian Belles 1 clear, 1 frosted; 2 Flamingo 1 oz. colognes d/o H; Sahara including Empress ash tray H, ftd. 9" etched vase, 7" spiral optic vase; Greek Key 1/2 gal. jug; Moongleam 4 1/2" vase, d/o; small after dinner cup; much more plus a lot of other good glass, china and furniture.

DOORS OPEN AT 2:00 PM FOR INSPECTION

Sale Conducted by Auctioneer J. Robert Sweeney,

Plain City Auction Service

ROUTE 202 - P. O. Box 242
LAHASKA, PA 18931
215-794-7800

LYNNE



ART'S

GLASS-HOUSE
INC.

P.O. BOX 54-6014
MIAMI BEACH, FL 33154
(305) 861-7700
(305) 895-5666

*Dear Heisey Collector and Dealer,
We're heading your way! Heisey animals,
lovely old patterns, and a rainbow of colors, will
be coming along with us.*

We'll be at the following shows.

FT. LAUDERDALE, FL	WAR MEMORIAL AUDITORIUM	JAN 29-FEB 1
MIAMI BEACH, FL	CONVENTION CENTER	FEB 6-11
MIAMI, FL	MIAMI EXPO CENTER	FEB 7-10
WEST PALM BEACH, FL	WEST PALM BEACH AUDITORIUM	FEB 20-22
PALM BEACH SHORES, FL	COLONNADES HOTEL	FEB 27-MAR 1

ED HAS OUR SHOP IN LAHASKA OPEN BY APPOINTMENT ALL THE
TIME.

Lynne and Art

9TH ANNUAL

STARLIGHT FLEA MARKET
SUNDAY, MARCH 15, 1981

STARLIGHT SCHOOL
116 North 22nd Street
North of West Main Street
Newark, Ohio

9:00 a.m. - 4:00 p.m. (firm times)

FOR FURTHER INFORMATION CALL:
614-366-5163

- Antiques
- Heisey Glass
- Pottery
- Crafts
- Something for Everyone

Managed by: Land of Legend Heisey Study Club
(Affiliate of HCA)

Food Available Donation 50¢

NEW CLUB FORMING IN CONNECTICUT -

If you are from the Connecticut
area and wish to join a new club now
forming contact:

Clare Nelson
c/o Gagne
6 Perron Rd.
Plainville, CT 06062
Phone: 203-747-9307

352 Flat Panel

Bedroom Set



We assume no responsibility for errors in these ads after the first printing Editor
For changes in ads during the year, please send \$1.00 per line.

- MOSTLY HEISEY**
RHODA CURLEY
16 Clayton Place
Albany, New York 12209
By Appointment (518)482-6272
- LAST CHANCE ANTIQUES**
42 N. Federal Hwy., Dania, Fl. 33004
(Between Miami & Ft. Lauderdale)
Large HEISEY Inventory & other Glass
Mail Orders (305)467-6356 (home)
- GOLDSBERRY'S ANTIQUES**
KALAMAZOO, Michigan
Shows Only -- Buy & Sell
HEISEY A Speciality
Phone: (616)381-3013
- SCHWAN'S ANTIQUES**
Route 1, Box 175B
John Tyler Highway
WILLIAMSBURG, VA. 23185
(804)229-7873 Shop and Shows
- GREEN ACRES FARM**
Antiques, Crystal Glass & Collectibles
2678 Hazelton Etna Road, S.W.
(S.R. 310 N.) Pataskala, Oh. 43062
Sat. & Sun. P.M. or Call (614)927-1882
- BERT'S BUDGET SHOP**
General Line Antiques
403 W. Main St., Newark, Oh. 43055
Phone: (614)349-8045
- THE WOODEN SHOE**
Antiques & Collectibles-Buy & Sell
Glass, Furniture, Estates
Jim & Sheri Vanes, By Appointment
Hemdon, Va. 22070 Phone: 435-9045
- CURIOSITY NOOK**
"Where Friends Meet To Antique"
3300 S. 8th. Ave. Westward Village
Yuma, Ar. 85364 (602)726-6730 or 726-8070
Barney & Jody Barnicle
- CURIO CORNER**
Accent Antiques of Kensington
3742 Howard Ave.
Kensington, Md. 20795
Phone: (301)933-3750
- ANTIQUES BOUGHT**
BOB SHULTZ SOLD
206-208 E. Main St., Route 419
Newmanstown, Pa. 17073
15 Mi. West of Reading, Pa.
Phone: (717)589-2819
- T & S ANTIQUES**
TOM MARTIN STEVE RODERICK
Specializing in Heisey
New Rochelle, N.Y.
(914) 235-9632
- C&J ANTIQUES**
COLE & JEAN MIESNER
BOX 45, 72WHIG ST.
NEWARK VALLEY, N.Y. 13811
(607) 642-9905
- OLDE LOVED THINGS**
ANTIQUES & COLLECTIBLES
Daris 'ed' Lacroix - Donald Mousseau
900 Ridgewood Avenue (Holly Hill)
Daytona Beach, Fl. 32017
HEISEY, CAMBRIDGE, Mail Order (904)252-7960
- OFF-BROADWAY ANTIQUES**
HEISEY GLASS & GENERAL ANTIQUES
121 S. Prospect St., Granville, Oh. 43023
Open 7 Days A Week 12-5 P.M.
Shop (614)587-2083 Sam 587-0052
- LYNNE & ART'S GLASS HOUSE, INC.**
'HEISEY OUR SPECIALTY'
Miami Beach, Fl. 33154
P.O. Box 54-6014
(305)861-7700 (305)895-5666
- HEISEY HEAVEN & other collectables**
Box 78 Rt. 1
Mansfield, Il. 61854
Ph: (217)489-4071
Hours by appointment or chance, Closed Fridays.
- WICKFORD ANTIQUE ARCADE**
RON & BEV WOOD Booths 6 & 7
650 Ten Rod Rd., N. Kingstown, R.I. 02852
Heisey, Primitives, Glass, Etc.
Home Phone: (401)295-0823
- DIAMOND H PLUS**
George & EILEEN SCHAMEL
Rt. 3 Box 419 Boonsboro, Md. 21713
Appointment or Mail Order
Phone: (301)432-6285
- HEIDI-HO ANTIQUES, INC.**
HEISEY and GENERAL ANTIQUES
838 S. High St., Columbus, Oh. 43206
Phone: (614)444-5774
Hours: Wed. - Sat. 11-5, Sun. 1-5
- BOB & FRAN'S ANTIQUES**
CHINA - HEISEY - GLASSWARE
SILVER FLATWARE
2007 Broadway Vancouver, Wa. 98663
Phone: (206)693-7972
- ANN'S GIFTS & ANTIQUES**
105 W. Main St., Hebron, Oh. 43025
Intersection Rt's 40 & 79
Next Door to Daisy Queen
Daily 11:30 A.M. to 5:30 P.M. Closed Thursday
- SUM OF LIFE**
ELAINE & FRANK HUSTED
P.O. Box 102
Phoenixville, Pa. 19460
Phone: (215)935-2962
- RECOLLECTIONS**
THERESA WERT
Lahaska Antique Center
Route 202 Lahaska, Pa.
Phone: (215)794-8667
- DEBBIE DELANEY**
Spec. in HEISEY and HUMMELS
BUY - ANYTIME
SELL - SHOWS and MAIL ORDERS
Newark (614) 366-3741 evenings
- THE "FINDERS" ANTIQUES**
DAVID & SHIRLEY ROSE
513 E. Main Street
Newark, Oh. 43055
Phone: (614)349-7934
- MOUNDBUILDERS ANTIQUES**
IRENE RAUCK
1138 Moundview, Newark, Oh. 43055
Phone: (614)344-6043
Heisey & Animals General Antiques
- HAPPY HAVEN ANTIQUES**
MARY DUMKE
14319 Rattlesnake Road
Grass Valley, Ca. 95945
Phone: (916)273-9450
- CHARLES A. SHAW**
Glenwood Gardens - Rip Van Winkle
Yonkers, N.Y. 10701 Ph: (914)476-5175
American Glass
Shows and Mail Order
- THE SLEEPING FOX**
EVELYN & JAMES JORDAN
P.O. Box 583
Lansdale, Pa. 19446
Phone: (215)855-2480
- GEORGE HOFFMAN ANTIQUES**
G.W. HOFFMAN - J.H. DENNIS
129 South 4th. Street
Newark, Oh. 43055
Phone: (614)345-8021
- CHARLES & MILDRED FISHER**
Antiques & Collectibles, General Line
HEISEY, DEGENHART, IMPERIAL
991 Idlewild, Newark, Oh. 43055
Phone: (614)522-5398
- HARRISON'S ANTIQUES**
HEISEY, CAMBRIDGE, DUNCAN
26 Johnston's Lane
Mercersburg, Pa. 17236
Shows, Mail, By Appt. (717) 328-2451
- THE CONNECTICUT YANKEE**
'HEISEY OUR SPECIALTY'
707 S. Washington
Fredericksburg, Tx. 78624
(512) 997-4992
- H and R DIAMOND H**
HELEN & ROBERT RAREY
1450 WHITE ASH DRIVE
Columbus, Oh. 43204
(614) 279-0390 after 5:30
- RAMBLING LANE ANTIQUES**
KEITH & EVELYN HOOVER
Featuring HEISEY and Other Fine Glass
Rt. 4 Box 1005 Rineland, Wi. 54501
Phone: (715)282-5019
- RENATTA'S RELICS**
515 North st., Utica, Oh.
Antiques & Collectibles
Open Thurs-Sat 12-6 or by App't
Phone (614) 892-2488

MAKE YOUR RESERVATIONS NOW...CONVENTION 1981--JUNE 18-19-20-21, 1981

The SHERATON INN will once again be our convention headquarters for 1981, and they have given a special room rate for all H. C. A. members. All activities will be held there with the exception of the SHOW AND DISPLAY. Please make your reservations early because last year they were all taken by the first of March.

The rate given us is ONE PERSON - \$32.00 - TWO PEOPLE - \$37.00 Queen size ONE PERSON - \$35.00 - TWO PEOPLE - \$38.00. The queen size rooms all have steam baths. NO ADDITIONAL CHARGE FOR CHILDREN UNDER 18 YEARS OF AGE AND NO ADVANCE DEPOSIT IS NEEDED. There is a \$5.00 charge per night for a rollaway bed.

SHERATON INN RESERVATION REQUEST

Name _____
 Address _____
 City _____ State _____ Zip _____
 Phone _____ All rooms have two double beds.
 Arrive _____ Single room requested (one person) \$32.00 _____
 Depart _____ Double room requested (two people) \$37.00 _____
 Please make your reservation by clipping the attached form Queen size requested (one person) \$35.00 _____
 Queen size requested (two people) \$38.00 _____
 Rollaway bed _____ \$ 5.00 _____

Mail to: ROBERT McCLAIN
 156 W. SHIELDS ST.
 NEWARK, OHIO 43055
 Phone: (614)345-8061

1981 SOUVENIR OSCAR FORM

PLEASE READ VERY CAREFULLY BEFORE FILLING OUT

Oscars are Light Blue, marked HCA '81' and IG. A limited edition of approximately 2600 to be offered to members at \$19.00 until May 31st. None will be sold between that date and the first day of the Convention, June 18, when they will be sold for \$22.00 if any are left. You may order ONE per member. This means ANY member who has a membership card regardless of class of membership. Please list all names as they WILL be checked. Everyone living in Ohio ordering for pick-up in Ohio, must pay 86¢ Sales Tax per Oscar. Shipping charges will be \$1.30 each. The Oscars will be shipped as soon as they are received.

DO NOT SEND DUES, BOOK ORDERS, ETC. WITH YOUR OSCAR ORDER. NO ORDERS WILL BE ACCEPTED WHICH ARE NOT ON YOUR ORIGINAL FORM FROM THE NEWSLETTER. See 'Desk of' in December newsletter for more information. Please keep this part for a reference and clip and mail the form below the line. Be sure your dues are currently paid. This is the fifth of a series of souvenir Oscars.





_____ Number of OSCARS AT \$19.00 _____ Only one per member
 Sales Tax \$1.05 _____ All Ohio Residents and Pick-Ups in Newark
 Postage \$1.30 each _____
 TOTAL sent with order _____

Check one: _____ Please mail my Oscar(s)
 _____ I will pick up my Oscar(s)
 at Convention or Museum after
 the Convention.

NAME(s) _____
 List all names _____
 ADDRESS _____
 CITY _____ STATE _____ ZIP _____

Make check payable to HCA, Inc.
 and mail to.....HCA OSCAR SALES
 P.O. BOX 27
 NEWARK, OHIO 43055

CHARGE MY
 Mastercharge Credit Card No. _____
 
 Expiration date required _____
 Mo. _____ Yr. _____

Monthly Heisey column
by Clarence Vogel!

glass REVIEW

80 PAGE ALL GLASS MAGAZINE
since 1971

\$9.50 per year - 12 Issues
Or, recent sample - \$1

The GLASS REVIEW is a handy 8½" x 5½" monthly magazine devoted to "Keeping Glass Collectors Informed" on both old & new glass. Printed on glossy stock and filled with large, clear photos, articles by nationally respected authors and writers, price reports, trends, research and reproduction information, previously unpublished catalog reprints, reviews of the latest glass books (and where to buy them), Questions & Answers, trademark info, large variety of glass ads on both old and new glass, up-to-date happenings in glass and MORE!

Enclose payment; send to: GLASS REVIEW,

Box 542
Marietta, Ohio 45750

HEISEY'S GLASSWARE of DISTINCTION

by Mary Louise Burns



COMPLETELY REVISED!

Now includes additional patterns, new illustrations, many new listings and is now perfect bound for sturdiness!

This comprehensive reference book is not a catalog reprint but a collection of all major patterns of tableware, stemware, cuttings, etchings, animals and Verlys produced through Heisey's 60 years of glassmaking.

Details of each pattern clearly shown by photo or illustrations for easy identification. Two indexes for easy reference: one by pattern name and one by pattern number.

All this for only \$11.95 pp.

.....
ALSO NEW: Completely revised price guide supplement to the above, listing each item and UPDATED price trends. Patterns are listed alphabetically for easy reference. Only \$5.95 pp!
.....

"ORDER NOW" Send check or money order to:
MARY LOUISE BURNS
P.O. Box 1931
Grants Pass, Or 97526

6 Books or more 40%



return to:
HEISEY NEWS
Box 27
Newark, OH 43055



FIRST CLASS MAIL
U.S. POSTAGE
PAID
PERMIT 34
Reynoldsburg, Ohio 43068

MUSEUM HOURS ARE NOW 1-4P.M. Wednesday, Saturday & Sunday until March

H INDICATES MARKED
X INDICATES IMPERFECTION OR DAMAGE

ALL ITEMS CRYSTAL UNLESS COLOR IS INDICATED

1	1404	OLD SANDWICH Oval Cr & Sugar H	49	4044	NEW ERA 2 Lt Candle, Pr
2	500	OCTAGON Cr & Sugar, Crystal, Moongleam Handle H	50	134	TRIDENT 2 Lt Candle, Pr, Sahara H
3	1519	WAVERLY Cr & Sugar H X	51	1540	LARIAT 2 Lt Candle, Pr
4	479	PETAL (Hotel) Cr & Sugar, Flamingo H	52	1541	ATHENA 2 Lt Candle, Pr
5	1020	Cr & Sugar H	53	4044	NEW ERA 2 Lt Candle, Pr, Bobeches, Frosted
6	1401	EMPRESS Cr & Sugar, Flamingo H	54	1428	WARWICK 5" Vase & 1 Lt Candle, Pr H
7	353	MED FLAT PANEL, Cr & Sugar H	55	1503	CRYSTOLITE 10" Flared Bowl & 3 Lt Candle
8	1540	LARIAT Cr & Sugar & Tray H	56	150	BANDED FLUTE Hd1 Chamberstick H X
9	350	PINWHEEL & FAN Creamer H X	57	16	7 1/2" Candle, Pr
10	1401	EMPRESS Creamer, Sahara H	58	1503	CRYSTOLITE Single Candle, Pr
11	1447	ROCOOCO Cr & Sugar H	59	110	DOLPHIN 1 Lt Candle, Pr
12	1170	PLEAT & PANEL Cr & Sugar, Flamingo H	60	1503	CRYSTOLITE 3 Lt Candle
13	1483	STANHOPE (Blk Knobs) Cr & Sugar H	61	1509	QUEEN ANN 1 Lt Candle w/ Prisms, Pr
14	1295	BEADED SWAG Cr & Sugar H (Cr X)	62	113	MARS 3 1/2" Candle, Pr, Flamingo
15	355	QUATOR Ind Creamer H X	63	1252	TWIST 1 Lt Candle, Pr, Marigold H
16	473	NARROW FLUTE W/RIM 6 1/2" Ftd Cov Preserve, Gold & Blue Dec H	64	1591	Cabochoon Nappy Candle H
17	1485	SATURN Tumbler in Metal Holder - Marmalade Jar H	65	1485	SATURN 4" Violet Vase (Rose Bowl), Zircon (Minor chip on base) H
18	352	FLAT PANEL 2 oz Oil (Wrong Stopper) H	66	4224	IVY Vase (Minor roughness on throat), Tangerine
19	1506	WHIRLPOOL Pansy Vase H & 1503 CRYSTOLITE Syrup (Incomplete Hd1)	67	1401	EMPRESS DF Floral Bowl & Candle, Pr, Unk Cut, Sahara (Minor chip on 1 base)
20	1252	TWIST Oil & Vinegar Bottle, Sahara	68	3359	PLATEAU 6" Rose Bowl DO, Moongleam
21	1469	RIDGELEIGH Cruet	69	1252	TWIST Ice Bucket, Marigold, Crazed H
22	1567	PLANTATION Cov Marmalade (1) & Tray H	70	1184	YEOMAN 6 1/2" Hd1 Bon Bon, Hawthorne
23	1519	WAVERLY Tall Ftd Candy Box & Cov, Seahorse Handle, BPOE Etch	71	1183	REVERE 6" Comport, Swirl, Flamingo H
24	465	RECESSED PANEL 1/2" Candy Jar & Cov Yellow Iridized H	72	1509	QUEEN ANN Ice Bucket, No Hd1
25	1540	LARIAT Round Oil Bottle (Cologne)	73	1255	PINEAPPLE & FAN 6" Vase
26	300	PEERLESS Bitter Bottle H X	74	411	RIB & PANEL 7 3/4" Vase
27	352	FLAT PANEL Oil Bottle H	75	440	Pressed Floral Vase H
28	1183	REVERE Sugar Shaker, Insert-X	76	1205	FANCY LOOP 8" Vase
29	1201	FANDANGO Sugar Shaker (Not orig top)	77	1469	RIDGELEIGH 8" Vase, Sahara H
30	416	HERRINGBONE Soup H	78	1428	WARWICK 7" Vase, Pr
31	439	RAISED LOOP 8 1/2" Nappy H	79	1540	LARIAT 7" Vase
32	1235	BEADED PANEL & SUNBURST 9" Nappy, Gold Dec	80	1540	LARIAT 7" Vase
33	1632	LODESTAR 8" Bowl, Dawn	81	1540	LARIAT 5 1/2" Vase
34	1519	WAVERLY 9" Bowl, Crimped, Shallow	82	1413	CATHEDRAL vase, sahara H
35	1201	FANDANGO 10" Shallow Nappy	83	1205	FANCY LOOP 7" Nappy, Gold Dec, in Metal DF Mounting
36	V8636	THISTLE Bowl, Verlys by Heisey, Limelight X	84	1503	CRYSTOLITE Pitcher
37	357	PRISON STRIPE 8 1/2" Flared Nappy H X	85	341 1/2	PURITAN 3 Pt Pitcher H X
38	1170	PLEAT & PANEL 8 1/2" Nappy, Flamingo H	86	393	NARROW FLUTE 3 Pt Jug H
39	1540	LARIAT 14" Gardenia Bowl	87	1201	FANDANGO Water Bottle
40	1252	TWIST 8" Low Ftd Bowl, Flamingo H	88	339	CONTINENTAL Water Bottle (Heavily Used)
41	1472	PARALLEL QUARTER 11" Floral Bowl w/#492 King House Etch H	89	4225	COBEL 1 Qt Cocktail Shaker, Arctic Etch
42	1401	EMPRESS 10" Oval Vegetable Bowl H	90	4225	COBEL 2 Qt Cocktail Shaker, cut
43	1401	EMPRESS 8" Bowl, Flamingo H	91	4225	COBEL 1 Qt Cocktail Shaker, Stopper-X
44	1519	WAVERLY 11" Oval Bowl H X	92	3355	FAIRACRE Ftd Sherbet, 1 ea & Champagne, 4 ea 1-X
45	1540	LARIAT Mayo & Underplate w/Ladle H	93	3355	FAIRACRE Goblet, 4 ea H 3-X
46	1503	CRYSTOLITE 11 1/2" Floral Bowl	94	3368	ALBEMARLE 8 oz ftd soda DO, 8 ea X
47	4054	CORONATION 13" Ice Lip Tankard & Slim Jim, 6 ea	95	1540	LARIAT Ftd Sherbet & Champagne
48	1503	CRYSTOLITE Sq Hurricane Bases, Pr, No Globes H	96	1540	LARIAT Goblets, 7 ea
			97	1540	LARIAT Goblets, w/Moonglo Cut, 8 ea

___ 98	1485 SATURN Goblets, Zircon, 2 ea H	___ 150	407 COARSE RIB 7½" Plate, Hawthorne, 6 ea H
___ 99	3366 TROJAN Goblet DO, Hawthorne	___ 151	407 COARSE RIB 7" Plates, Flamingo, 3 ea H
___ 100	3389 DUQUESNE Cocktail, Tangerine Bowl	___ 152	1252 TWIST Ohio Sesquicentennial Platter
___ 101	1506 WHIRLPOOL 12 oz Ftd Ice Tea, Limelight H	___ 153	1236 EAGLE 8" Plate, Moongleam
___ 102	3380 OLD DOMINION Goblet, Sahara	___ 154	1559 COLUMBIA 14" Torte Plate
___ 103	3380 OLD DOMINION Goblet X	___ 155	1509 QUEEN ANN 15" Torte Plate w/#913 Everglade Cut
___ 104	3376 ADAM Goblet, #169 Biltmore Etch, Flamingo	___ 156	1238 BEEHIVE 14" Plate X
___ 105	4091 KIMBERLY Goblets, Unk Cut, 6 ea H	___ 157	1401 EMPRESS 12" Sq Sandwich Plate, Center Handle
___ 106	3368 ALBEMARLE Goblet, #867 Chateau Cut	___ 158	1485 SATURN 8" Plate, Zircon, 3 ea
___ 107	451 CROSS-LINE FLUTE Goblet H	___ 159	1401 EMPRESS 8" Sq Plate, Sahara, 8 ea H
___ 108	4091 KIMBERLY Goblet, #944 Courtship Cut	___ 160	1183 YEOMAN 8" Plate DO, Flamingo, 8 ea
___ 109	5013 SHASTA Goblet H	___ 161	393 NARROW FLUTE 5½" Plate, 6 ea H
___ 110	1540 LARIAT Goblet	___ 162	1401 EMPRESS 7" Sq Plate w/#450½ Formal Chintz Etch H
___ 111	3350 WABASH Goblet, Unk Etch, Gold Dec H	___ 163	1401 EMPRESS 7" Rd Plate, Sahara, 3 ea H
___ 112	1469 RIDGELEIGH Goblet X	___ 164	1401 EMPRESS 7½" Rd Plate, Sahara, 4 ea H
___ 113	5003 CRYSTOLITE Goblet, 5 ea & Sherbet, 5 ea 1-X	___ 165	1495 FERN 6" Cheese Plate
___ 114	1170 PLEAT & PANEL Goblet, Unk Cut, Flamingo	___ 166	4182 8½" Plate w/#5020 Lily Carving
___ 115	395 COLONIAL Goblet, 2 ea H	___ 167	1512 STIPPLED ROCOCO 8" Plate
___ 116	1183 YEOMAN Goblet DO, 2 ea	___ 168	1183 YEOMAN 10½" Plate DO, Hawthorne, 4 ea
___ 117	1567 PLANTATION Sugar, Goblet, 2 ea, Sherbet, 3 ea, & Oyster Cocktail, 2 ea All H	___ 169	1540 LARIAT 12" Gardenia Bowl
___ 118	5024 OXFORD Champagne, 4 ea H	___ 170	473 NARROW FLUTE W/RIM Ind Strawberry & Sugar
___ 119	5057 SUEZ Champagne, Unk Cut H	___ 171	1185 YEOMAN Center Handled Sandwich, Signed "Sinclair"
___ 120	1540 LARIAT Champagne, 4 ea	___ 172	7000 SUNFLOWER 8" Rd 3 Part Relish H X
___ 121	3324 DELAWARE Saucer Champagne, Flamingo	___ 173	1401 EMPRESS 7" Triplex Relish, #448 Old Colony Etch, Stained Yellow
___ 122	5003 CRYSTOLITE Sherbet	___ 174	1401 EMPRESS 10" Triplex Relish, Frosted, Silver Dec H
___ 123	351 PRISCILLA Saucer Champagne, 3 ea H	___ 175	1503 CRYSTOLITE 8" 3 Part Relish
___ 124	393 NARROW FLUTE 3 oz Cocktail H	___ 176	1951 CABOCHON 3 Part Relish
___ 125	1425 VICTORIAN 2 oz Wine, 9 ea H	___ 177	1503 CRYSTOLITE 7" Bon Bon, 2 Hd1
___ 126	3408 JAMESTOWN Sherry, #965 Narcissus Cut H	___ 178	1503 CRYSTOLITE 3 Part Relish, 5½" Ftd Cheese, 5" Breakfast Preserve
___ 127	1252 TWIST Sherbet, 3 ea H	___ 179	1229 OCTAGON Bon Bon w/Unk Cut, & Mint Dish, Hawthorne
___ 128	3318 WALDORF Cocktails, #467 Tally Ho Etch, 2 ea	___ 180	1252 TWIST Bon Bon, Moongleam
___ 129	3357 KING ARTHUR Cocktail, #442 Diana Etch	___ 181	1229 OCTAGON Bon Bon, Flamingo
___ 130	4002 AQUA CALIENTE Cocktail, Unk Cut	___ 182	1229 OCTAGON Bon Bon, Moongleam
___ 131	341 OLD WILLIAMSBURG 3 oz Cocktail H	___ 183	1229 OCTAGON Mayo DO, Flamingo
___ 132	3381 CREOLE Sherbet DO, Sahara Bowl	___ 184	1229 OCTAGON Mayo, Hawthorne
___ 133	3381 CREOLE Sherbet DO, Sahara Bowl	___ 185	1229 OCTAGON Mayo, Moongleam
___ 134	3390 CARCASSONNE Sherbet, Sahara H	___ 186	1229 OCTAGON 6" Handled Mint DO
___ 135	3333 OLD GLORY Goblet, Renaissance Etch, Gold Filled, 6 ea H	___ 187	1229 OCTAGON 6" Hd1 Mint, Hawthorne
___ 136	3308 BOB WHITE Goblet, Peacock Etch	___ 188	1229 OCTAGON 6" Hd1 Mint, Marigold
___ 137	3404 SPANISH Goblet, #461 Concord Etch	___ 189	1252 TWIST Cheese Plate, Flamingo H
___ 138	339 CONTINENTAL Goblet	___ 190	411 RIB & PANEL 6" Cheese Plate, Moongleam
___ 139	1540 LARIAT Ftd Ice Tea, 9 ea H	___ 191	1485 SATURN 5" Nappy, Zircon H
___ 140	1540 LARIAT Cocktail, 12 ea	___ 192	1485 SATURN Baked Apple, Zircon H
___ 141	411 TUDOR Parfait, 2 ea H	___ 193	315 paneled cane 5" Ftd Jelly H
___ 142	4091 KIMBERLY Goblet, #1015 Dolly Madison Cut H	___ 194	407 COARSE RIB 5" Ftd Jelly H
___ 143	3390 CARCASSONNE Sherbet, Sahara H	___ 195	1201 FANDANGO One Hd1 Jelly
___ 144	1243 STEPPED OCTAGON 7" Plate, Moongleam, 5 ea H	___ 196	315 paneled cane Hd1 Jelly H
___ 145	1404 OLD SANDWICH 8" Plate, 9 ea H	___ 197	1205 FANCY LOOP Hd1 Jelly
___ 146	1223 FLUTED BORDER 8" Plate, 6 ea H	___ 198	1205 FANCY LOOP 4½" Shallow Nappy
___ 147	1223 FLUTED BORDER 7" Plate, 10 ea H	___ 199	1428 WARWICK 9" Vase, Pr H
___ 148	407 COARSE RIB 7" Plate, 7 ea		
___ 149	407 COARSE RIB 6" Plate, Hawthorne, 6 ea H		

200	1401	EMPRESS 9" DF Vase, Sahara H X	249	433	GRECIAN BORDER Ftd Banana Split
201	1205	FANCY LOOP 8" Vase X	250	433	GRECIAN BORDER Ftd Banana Split H
202	305	PUNTY & DIAMOND POINT 8" Vase	251	1189	YEOMAN 13" 2 Part Pickle & Olive, Flamingo
203	451	CROSS-LINE FLUTE Vase H	252	1189	YEOMAN 13" Celery, Flamingo H
204	1555	CORNUCOPIA Vase	253	341	PURITAN Pickle Dish, 2 ea H
205	1205	FANCY LOOP 9" Comport, Tall	254	1252	TWIST 3 Part Relish, Flamingo H
206	350	PINWHEEL & FAN 8" Nappy H X	255	1252	TWIST 6" Pickle, Moongleam H
207	394	NARROW FLUTE Dr Johnson Punch Bowl H	256	468	12" Celery, Flamingo H
208	350	PINWHEEL & FAN Punch Bowl Base H	257	1228	SWIRL 6" Baked Apple, Moongleam H
209	1235	BEADED PANEL & SUNBURST Punch Bowl Base H	258	1223	PRESSED DIAMOND Cereal Bowl, Hawthorne H
210	335	PRINCE OF WALES Sm Punch Bowl Base	259	1401	EMPRESS Triplex Relish, Moongleam H
211	1401	EMPRESS 12" Rd Hd1 Sandwich Tray, Moongleam & 8" Rd Salad Plate, Moongleam, 6 ea H	260	1183	REVERE 4" Cov Lemon Dish, Unk Cut H
212	1184	YEOMAN 9½" Oyster Cocktail Plate, Vaseline H	261	427	DAISY & LEAVES 5" Nappy (Flowers Frosted) H
213	1184	YEOMAN 9" Oval Baker, Moongleam H	262	393	NARROW FLUTE 5" Shallow Nappy, Enam Dec H
214	1540	LARIAT 7" Nappy X	263	407	COARSE RIB 12" Celery H
215	1540	LARIAT 15" Oval Platter X	264	466	PANEL & DOUBLE PLEAT 8" Nappy H
216	1540	LARIAT 13" Celery	265	1401	EMPRESS Oval Nappy, 2 ea H
217	341	OLD WILLIAMSBURG Punch Cup, 6 ea H	266	1519	WAVERLY 6" 2 Part Relish
218	341	OLD WILLIAMSBURG Punch Cup, 5 ea (Some Cloudy) H	267	1469	RIDGELEIGH Bon Bon H
219	1503	CRYSTOLITE Punch Cup, 14 ea H	268	1401	EMPRESS 4" Nappy & Underplate, Flamingo H
220	1540	LARIAT Cup & Saucer, 4 sets (1 Cup-X)	269	1401	EMPRESS 7" Triplex Relish, Center Hd1 H
221	1201	FANDANGO Punch Cup, 8 ea	270	1401	EMPRESS 6" Ftd Mint, Silver Overlay
222	339	CONTINENTAL Punch Cup, 2 ea	271	1509	QUEEN ANN 6" Ftd Jelly H X
223	1231	RIBBED OCTAGON Cup & Saucer, 5 sets, (1 Extra Saucer) Flamingo H	272	1519	WAVERLY 6½" 2 Part Relish
224	1485	SATURN Cup & Saucer, Zircon H	273	1401	EMPRESS 5½" Mayo DF, Sahara H
225	1252	TWIST Kraft Cheese Plate	274	1401	EMPRESS 5½" Mayo DF
226	407	COARSE RIB Goblet, 6 ea	275	1401	EMPRESS 4" Nappy, 3 ea H 1-X
227	3368	ALBEMARLE Goblet, #867 Chateau Cut	276	355	QUATOR Sugar, Unk Cut H
228	3368	ALBEMARLE Cocktail, #867 Chateau Cut	277	7025	HALF CIRCLE Ind Cr & Sugar, Sahara H
229	3389	DUQUESNE Champagne, #848 Botticelli Cut	278	1519	WAVERLY Cr & Sugar H
230	5024	OXFORD Goblet H	279	1506	PROVINCIAL Cr & Sugar H
231	5024	OXFORD Claret H	280	479	PETAL Cr & Sugar H
232	1205	FANCY LOOP Punch Glass	281	1023	Cr & Cov Sugar, Flamingo H
233	3350	WABASH Parfait, Pied Piper Etch, 3 ea H	282	1519	WAVERLY Cr & Sugar H
234	2930	PLAIN & FANCY Tumbler, #166 Mayflower Etch, 8 ea	283	1951	CABOCHON Sugar, Moonglo Cut H
235	1590	ZODIAC Ice Tea, 2 ea	284	1540	LARIAT Sugar H
236	3370	AFRICAN Champagne, Moongleam Stem	285	1503	CRYSTOLITE Sugar H
237	1118	INDIAN HILL 6½" Tall Grapefruit	286	1540	LARIAT Cr & Sugar H
238	3404	SPANISH 6 oz Saucer Champagne	287	150	POINTED OVAL IN DIAMOND POINT Sugar, no Lid
239	1483	STANHOPE Champagne	288	1540	LARIAT Cr & Sugar & Tray
240	4055	PARK LANE Ice Tea, #842 Singapore Cut	289	1401	EMPRESS Ind Cr & Sugar, Sahara H
241	818	FIFTH AVENUE 10 oz Goblet, 2 ea H	290	1425	VICTORIAN Cr & Sugar H
242	4054	CORONATION Slim Jim, 4 ea	291	354	WIDE FLAT PANEL Cr & Sugar, Flamingo H
243	1540	LARIAT Goblet, 6 ea	292	1280	WINGED SCROLL Spoon, Emerald, Gold Dec H
244	2351	10 oz Soda, #166 Mayflower Etch, 6 ea	293	1503	CRYSTOLITE 7" Candy Box, Brass Lid H
245	4044	NEW ERA Cocktail, Monogram G, 6 ea	294	1020	Cr & Sugar, Vaseline Cr-X
246	4044	NEW ERA Juice, Monogram G, 6 ea	295	1401	EMPRESS Ind Cr & Sugar H
247	1252	TWIST 5 oz Saucer Champagne, Marigold	296	1201	FANDANGO Cr & Sugar, Gold Dec X
248	1252	TWIST Ftd Juice, Marigold, 2 ea H	297	7000	SUNFLOWER Cr & Sugar H
			298	355	QUATOR Cr & Sugar H
			299	412	RIB & PANEL Sugar, Hotel H
			300	1503	CRYSTOLITE 7" Candy Box H
			301	465	RECESSED PANEL 1# Candy H
			302	1184	YEOMAN 7" Candy Box, Unk Cut H

303	1559	COLUMBIA 1 Lt Candle, Crimped, Pr	350	Ringneck Pheasant, 2 ea
304	1503	CRYSTOLITE Single Candle, Pr	351	Ringneck Pheasant
305	1541	ATHENA 2 Lt Candle, Pr	352	Ringneck Pheasant, Enam Paint
306	103	3" Candle, Saucerfooted	353	Fish Candlestick, Enam Paint, 2 ea
307	1565	LEAF Candle, Pr X	353A	Fish Candlestick, 2 ea
308	112	9" Candle, Pr, Moongleam H	354	Standing Colt
309	4044	NEW ERA 2 Lt Candelabra w/Bo- beches & Prisms, Frosted X	354A	Standing Colt, Cobalt
310	301	2 Lt Candelabra, Pr, Sahara H X	354B	Standing Colt, Cobalt
311	135	Candle, Pr, Arctic Etch	355	Fish Bookend, 2 ea
312	100	9" Candle, Pr H	355A	Fish Bookend, 2 ea
313	140	2 Lt Candle, Unk Cut	355B	Fish Bookend, 2 ea
314	4044	NEW ERA 2 Lt Candelabra, w/Bobeches & Prisms, Pr	356	Scotty
315	1	9" Candle, Pr	356A	Scotty
316	1405	IPSWICH Candle Inserts, Pr, Sahara H	356B	Scotty
317	107	10" Candle, Pr, Flamingo, H	357	Rooster Vase
318	1509	QUEEN ANN 1 Lt Candelabra w/Prisms, Pr	357A	Small Elephant
319	1504	REGENCY 2 Lt Candle w/#341 Old Williamsburg Epergnettes	357B	Small Elephant
320	1469	RIDGELEIGH 6" Candle Vase, Sahara H	358	Fighting Rooster X
321	367	PRISM BAND Decanter, Moongleam, Frosted, Crystal Stopper, (Dec-Cloudy, Stopper-X)	358A	Clydesdale
322	325	PILLOWS Water Bottle	358B	Clydesdale
323	1235	BEADED PANEL & SUNBURST Water Bottle	359	Sparrow
324	339	CONTINENTAL Water Bottle	360	Sparrow
325	343	SUNBURST Water Bottle	360A	Horsehead Bookend, 2 ea 1-X
326	367	PRISM BAND Decanter	361	14 Kingfisher Floral Block, Moongleam H
327	6060	COUNTRY CLUB Cocktail Shaker, Rooster Stopper	361A	13 12" Floral Bowl, Moongleam H
328	4225	COBEL Cocktail Shaker, Sportsman Etch	362	1 Madonna
329	4225	COBEL 1 Qt Cocktail Shaker, #1066 Debutante Cut, Silver Base & Top of Stopper	362A	1591 Child's Mug, Elephant Hd1 H
330	4225	COBEL 2 Qt Cocktail Shaker, Unk Cut	363	5058 Penguin 1 Qt Decanter X
331	433	GRECIAN BORDER 3 Pt Jug H	364	5038 Rooster Stem Cocktail
332	1404	OLD SANDWICH Pitcher & 12 oz Soda, 4 ea H	365	15 Duck on Pedestal, Frosted X
333	341	1/2 PURITAN 2 Qt Pitcher H	366	1489 PURITAN Horsehead 4" Cigarette Box, Frosted Head
334	411	RIB & PANEL 1 1/2 Qt Jug	367	Horsehead Stem from 5066 Sherry
335	1295	BEADED SWAG Tankard, 8 oz Tumbler 2 ea (1-X) Ruby Stain Souvenir	368	4035 3/4 Cologne, #77 Duck Stopper, Iridized
336	341	PURITAN 1 Pt Pitcher H	369	407/109 PETTICOAT DOLPHIN Comport, Flamingo
337	341	1/2 OLD WILLIAMSBURG 3 Qt Squat Jug H	370	109 PETTICOAT DOLPHIN Candle, Pr, Flamingo X
338	1503	CRYSTOLITE Pitcher	371	110 SANDWICH DOLPHIN Candle, Pr, Flamingo
339	1295	BEADED SWAG Tankard, Opal, Pink Daisy Dec	372	110 SANDWICH DOLPHIN Candle, Pr
340	150	POINTED OVAL & DIAMOND POINT Jug	373	1210 FROG Hd1 Plate
341	350	PINWHEEL & FAN 2 Qt Jug H	374	1519 WAVERLY 11" Seahorse Ftd Floral Bowl H
342	341	1/2 OLD WILLIAMSBURG 3 Qt Squat Jug H X	375	3405 ALIBI Cocktail, Chicken Chase Etch, Moongleam Ft
343	385	GRID & SQUARE Tankard, Sterling Silver Overlay	376	3405 ALIBI Cocktail, #460 Club Drinking Scene Etch, 2 ea
344	1250	GROOVE & SLASH 1/2 Gal Tankard, Metal Top	377	3397 GASCONY 2 oz Wine, #455 Sports- man Etch, 4 ea
345	150	BANDED FLUTE Beer Mug H	378	2401 8 oz Old Fashion, #495 Polo Player Etch
346	150	BANDED FLUTE Beer Mug H	379	2401 8 oz Old Fashion, 467 Tally Ho
347	1404	OLD SANDWICH Beer Mug, Sahara H X	380	2401 6 oz Soda, #496 Skier Etch
348	1220	PUNTY BAND Mug, Custard	381	2401 6 oz Soda, #463 Equestrian Etch
349	3407	Beer Mug, Cobalt, Crystal Hd1	382	2401 5 oz Soda, #467 Tally Ho Etch
			383	2401 8 oz Soda, #467 Tally Ho Etch
			384	2401 8 oz Soda, #462 Fox Chase Etch
			385	6060 COUNTRY CLUB Soda, #517 Winchester '73 Etch
			386	4163 Beer Mug, #462 Fox Chase Etch
			387	3355 FAIR/CRE Sherbet, Unk Optic H
			388	3381 CREOLE 7 oz Sherbet, Sahara Bowl
			389	3317 DRAKE Saucer Champagne MO, Tatting Needle Etch, 2 ea

___ 390	5082	MID CENTURY Sherbet, 6 ea H	___ 443	52	Short Ind Salt & Pepper, Hawthorne, Cloudy H
___ 391	3308	BOB WHITE Sherbet, Peacock Etch, 4 ea	___ 444	52	Short Ind Salt & Pepper, Flamingo H
___ 392	3390	CARCASSONNE Sherbet, Sahara, 5 ea	___ 445	52	Short Ind Salt & Pepper H
___ 393	1485	SATURN Sherbet, Zircon	___ 24	PANELED CONE Salt H	
___ 394	1485	SATURN Sherbet, Zircon, 2 ea	___ 447	1121	OCTAGON Salt Dip
___ 395	1252	TWIST Sherbet, Flamingo, 4 ea H	___ 448	1183	REVERE Ind Salt, Moongleam
___ 396	1226	COLONIAL Sherbet, 10 ea H	___ 449	1205	FANCY LOOP Celery Salt, 2 ea X
___ 397	347	COLONIAL 4 oz Sherbet, 2 ea	___ 450	1509	QUEEN ANN Nut Dish
___ 398	1776	KALONYAL Sherbet, 6 ea 2-X	___ 451	1401	EMPRESS Nut Dish, Sahara H
___ 399	339	CONTINENTAL Ftd Sherbet H	___ 452	1401	EMPRESS Nut Dish, Flamingo, 6 ea H X
___ 400	393	NARROW FLUTE 4 oz Low Ftd Sherbet, 4 1/2" Underplate, 4 sets 1-X	___ 453	353	MED FLAT PANEL Ind Almond, Flamingo
___ 401	349	COLONIAL 4 1/2 oz High Ftd Sherbet H	___ 454	353	MED FLAT PANEL Ind Almond, Flamingo
___ 402	1540	LARIAT Punch Bowl Underplate	___ 455	353	MED FLAT PANEL Ind Almond, 4 Crystal, 2 Flamingo H 2 2 5/2
___ 403	1401	EMPRESS 6" Rd Plate, Alexandrite H	___ 456	3316	BILTMORE Almond DO, Moongleam, Ftd, 3 ea, 1-X
___ 404	1401	EMPRESS 7" Rd Plate, Alexandrite H	___ 457	1229	OCTAGON Ind Almond, Flamingo, 4 ea H
___ 405	1150	COLONIAL STAR Plate, Alexandrite H	___ 458	353	MED FLAT PANEL Ind Almond, 6 ea 1-X H
___ 406	1401	EMPRESS 6" Saucer, Tangerine H	___ 459	1483	STANHOPE Ind Nut, Cut, Red Knob
___ 407	1183	REVERE 11" Oval Platter, Sq Trellis Cut, Gold Rim H	___ 460	1404	OLD SANDWICH Ind Ash Tray, 2 Sahara, 2 Crystal 1-X H
___ 408	353	MED FLAT PANEL Humidor, Zircon H	___ 461	1404	OLD SANDWICH Ind Ash Tray, 5 ea H 1-X
___ 409	352	FLAT PANEL 2 Qt Crushed Fruit H	___ 462	1503	CRYSTOLITE 3" Sq Ash Tray, Zircon H
___ 410	352	MED FLAT PANEL 16 oz Lavendar Jar H	___ 463	1503	CRYSTOLITE 3" Sq Ash Tray, Zircon H
___ 411	1250	GROOVE & SLASH Humidor w/Silver-plate Art Lid	___ 464	1503	CRYSTOLITE 3" Rd Ash Tray, Zircon H
___ 412	459	8" Basket, Butterfly Cut H	___ 465	441	GRAPE LEAF Sq Ash Tray, Frosted X
___ 413	480	DAISY & LEAVES 7 1/2" Basket H	___ 466	341	PURITAN toothpick, ftd H H
___ 414	461	BANDED PICKET 7" Basket H	___ 467	1454	DIAMOND POINT Top Hat Cig Holder
___ 415	417	DOUBLE RIB & PANEL Basket, Moongleam H	___ 468	411	TUDOR 2 1/2 oz Bar Tumbler H
___ 416	1223	FLUTED BORDER Candy, Chrome Holder, Marigold Stain H	___ 469	300	PEERLESS 2 1/2 oz Bar H
___ 417	4045	7" Ball Vase, Sat Optic, Zircon X	___ 470	1425	VICTORIAN Bar Glass H
___ 418	4045	4" Ball Vase, Sat Optic, Zircon	___ 471	3397	GASCONY 2 oz Wine, Sahara, 2 ea H
___ 419	4045	7" Ball Vase, Alexandrite X	___ 472	2323	NAVY 2 oz Bar, Cobalt Base
___ 420	4045	9" Ball Vase, Cobalt	___ 473	1485	SATURN 5 oz Juice, Zircon H
___ 421	4203	9" Bud Vase MO, Moongleam	___ 474	300	PEERLESS Cordial H
___ 422	4224	Ivy Vase, Tangerine	___ 475	4091	KIMBERLY Cordial, Courtship Cut
___ 423	4220	4 1/2" Vase, Swirl Optic, Sahara	___ 476	3408	JAMESTOWN Cordial, Narcissus Cut H
___ 424	4075	Finger Bowl DO, Alexandrite	___ 477	5010	SYMPHONE Cordial, Minuet Etch
___ 425	1509	QUEEN ANN Ice Bucket, #502 Crinoline Etch	___ 478	5010	SYMPHONE Cordial, Minuet Etch
___ 426	1252	TWIST Ice Bucket, Alexandrite H	___ 479	1225	PLAIN BAND Claret, Engraved D M Weippert
___ 427	1401	EMPRESS Ice Bucket DF, Frosted, Silver Overlay, Plastic Ball	___ 480	5079	PAN AMERICAN Bell H
___ 428	407	COARSE RIB Cov Mustard, Marigold Stain H	___ 481	1404	OLD SANDWICH Ind Ash Tray, Sahara H
___ 429	1205	FANCY LOOP Mustard, (wrg lid-X)	___ 482	1280	WINGED SCROLL 5 1/2" Pin Tray, Custard
___ 430	1469	RIDGELEIGH Cov Mustard w/Paddle H	___ 483	50	CABOCHON Adv Sign, Frosted
___ 431		CRYSTOLITE (?) Miniature Mustard	___ 484	30	Toy Candlestick, Pr H
___ 432	1401	EMPRESS Cov Mustard w/Spoon, Sahara H	___ 485	4231	Favor Vase DO
___ 433	417	DOUBLE RIB & PANEL Cov Mustard H	___ 486	6	Mayo Ladle, Sahara H
___ 434	351	PRISCILLA Cov Mustard H	___ 487	10	Muddler
___ 435	1200	CUT BLOCK Ind Sugar, Custard, Souvenir	___ 488	10	Muddler
___ 436	1225	PLAIN BAND Toy Sugar, no Lid H	___ 489	379	URN 4" Nappy H
___ 437	393	NARROW FLUTE Ind Cr, Moongleam H	___ 490	1225	PLAIN BAND Toy Butter Base H
___ 438	393	NARROW FLUTE Ind Cr & Sugar, Flamingo H	___ 491	1637	ATOWN & COUNTRY 6" Plate, Experimental Black
___ 439	393	NARROW FLUTE Ind Cr & Sugar H X			
___ 440	150	BANDED FLUTE Salt & Pepper H X			
___ 441	1401	EMPRESS Salt & Pepper, Alexandrite, 1 Cloudy			
___ 442	1401	EMPRESS Salt & Pepper, Sahara			

___ 492	1485	SATURN 5" Whp'd Dressing Bowl, Zircon H	___ 535	3370	AFRICAN Goblet, 3 ea, Flamingo
___ 493	1485	SATURN 5" Whp'd Dressing Bowl, Zircon H	___ 536	1485	SATURN Goblet, Zircon
___ 494	1506	WHIRLPOOL 10" 4 Part Relish, Limelight	___ 537	1485	SATURN Goblet, Zircon
___ 495	1495	FERN 3 Part Relish, Zircon	___ 538	1485	SATURN Goblet, Zircon
___ 496	3379	PYRAMID 5 oz Soda, Flamingo	___ 539	1485	SATURN Goblet, Zircon
___ 497	3404	SPANISH Goblet, Tangerine, Red Side	___ 540	3381	CREOLE 12 oz Ftd Soda, Alexandrite
___ 498	7047	COMET LEAF Goblet, Alexandrite H	___ 541	3389	DUQUESNE 8 oz Ftd Soda, Tangerine
___ 499	341	OLD WILLIAMSBURG Goblet, Alexandrite H	___ 542	4054	CORONATION Soda, Unk Cut
___ 500	1495	FERN Dbl Candle, Orchid Etch	___ 543	4206	OPTIC TOOTH 12 oz Soda, 2 ea Moongleam Ft
___ 501	134	TRIDENT Candle, Pr, Orchid Etch	___ 544		Bell
___ 502	4035	Cigarette Holder, Orchid Etch	___ 545	1637	ATOWN & COUNTRY 8 oz Soda, Dawn H
___ 503	1401	EMPRESS 7" Triplex Relish, Orchid Etch	___ 546	1951	CABOCHON Tumbler, Pussywillow Cut H
___ 504	1509	QUEEN ANN 6" Ftd Mint	___ 547	1447	ROCOCO Ftd Tumbler H
___ 505	1509	QUEEN ANN 6 1/2" 2 Part Dressing, Orchid Etch	___ 548	3366	TROJAN 12 oz Soda, Trojan Etch, Moongleam Ft
___ 506	1519	WAVERLY 12" Floral Bowl, Orchid Etch	___ 549	2351	10 oz Soda, Screen Optic
___ 507	1519	WAVERLY 14" Torte Plate, Orchid Etch	___ 550	3380	OLD DOMINION 12 oz Ftd Soda, Empress Etch, Sahara
___ 508	1540	LARIAT Fan Vase, Orchid Etch	___ 551	3390	CARCASSONNE Ftd Ice Tea, Cobalt
___ 509	1519	WAVERLY Tall Ftd Candy w/Cover, Orchid Etch	___ 552	3390	CARCASSONNE Ftd Ice Tea, Cobalt, 2 ea
___ 510	1519	WAVERLY Oval Comport, Orchid Etch	___ 553	5057	SUEZ Ice Tea, Amber Stem H
___ 511	1519	WAVERLY 12" Floral Bowl, Orchid Etch	___ 554	3370	AFRICAN, Champagne, Moongleam Ft
___ 512	1519	WAVERLY 11" Floral Bowl, Seahorse Ftd, Orchid Etch	___ 555	3389	DUQUESNE Champagne, Tangerine X
___ 513	1509	QUEEN ANN Cup & Saucer, 8 Sets, Orchid Etch	___ 556	3390	CARCASSONNE Champagne, Cobalt
___ 514	5025	TYROLEAN Goblets, 4 ea, Orchid Etch	___ 557	1415	20TH CENTURY 12 oz Ice Tea, Dawn H
___ 515	5025	TYROLEAN Goblets, 4 ea, Orchid Etch	___ 558	5023	CONTINENTAL Ftd Ice Tea
___ 516	5025	TYROLEAN Champagne, 9 ea, Orchid Etch 1-X	___ 559	150	BANDED FLUTE 12 oz Ice Tea H
___ 517	1519	WAVERLY Cr & Sugar, Orchid Etch	___ 560	3389	DUQUESNE Ice Tea, Continental Cut, 3 ea
___ 518	1509	QUEEN ANN 11" Floral Bowl, Barcelona Cut	___ 561	4054	CORONATION Bar Glass, Unk Cut, 2 ea
___ 519	1401	EMPRESS Floral Bowl D/F, Normandie Etch	___ 562	2517	TEAR DROP Pitcher, Flamingo
___ 520	1401	EMPRESS 11" Floral Bowl D/F, Flamingo H	___ 563		10 oz Tumbler, West Point Etch
___ 521	1401	EMPRESS 11" Floral Bowl D/F, Alexandrite	___ 564	1401	EMPRESS 13" Celery, Flamingo H
___ 522	1401	EMPRESS 11" Floral Bowl D/F, Cobalt	___ 565	1184	YEOMAN Ftd Comport DO, Flamingo H
___ 523	1401	EMPRESS 11" Floral Bowl D/F, Moongleam	___ 566	1184	YEOMAN 11" Celery DO, Marigold, Crazed
___ 524	1485	SATURN 8 1/2" Cylinder Vase H	___ 567	3368	ALBEMARLE Oyster Cocktail, Pairpoint Cut, 8 ea (Rough)
___ 525	4054	CORONATION Vase X	___ 568	3404	SPANISH Oyster Cocktail, Florentine Cut
___ 526	6003	TEMPO Goblet, Fern Cut H	___ 569	3368	ALBEMARLE Oyster Cocktail, Chateau Cut
___ 527	3334	SEXTON Goblet, Unk Cut H	___ 570	3350	WABASH Cocktail, Frontenac Etch H
___ 528	3389	DUQUESNE Goblet, Botticelli Cut	___ 571	3368	ALBEMARLE Cocktail, Unk Cut
___ 529	3411	MONTE CRISTO Goblets, 7 ea, Unk Cut, 1-X, Some repaired	___ 572	3404	SPANISH Cocktail, Florentine Cut
___ 530	3416	BARBARA FRITCHIE Goblet, Manhattan Cut	___ 573	5042	CORINTHIAN Cocktail
___ 531	1295	BEADED SWAG Goblet, Custard, Rose Dec, Souvenir	___ 574	3368	ALBEMARLE Cocktail, Unk Cut
___ 532	4092	KENILWORTH Goblet H	___ 575	3333	OLD GLORY Cocktail, Renaissance Etch, 4 ea H
___ 533	3370	AFRICAN Goblet, Moongleam Stem	___ 576	1415	20TH CENTURY 5 oz Juice, Dawn H
___ 534	3370	AFRICAN Goblet, Moongleam Stem	___ 577	1205	FANCY LOOP 8 oz Tumbler, Emerald, Gold Dec
			___ 578	3304	UNIVERSAL 2 1/2 oz Wine & Unk Tumbler, Tattling Etch
			___ 579	351	PRISCILLA 4 oz Ftd Ale, Flamingo
			___ 580	351	PRISCILLA Wine H
			___ 581	349	COLONIAL 2 oz Wine
			___ 582	1108	PENELOPE Saucer-Ftd Egg Cup
			___ 583	4054	CORONATION Old Fashion, Screen Optic, Dawn (Experimental)
			___ 584	1205	FANCY LOOP Punch Glass X
			___ 585	2516	CIRCLE PAIR 8 oz Soda, Marigold
			___ 586	1401	EMPRESS 12 oz Soda H
			___ 587	2516	CIRCLE PAIR Tumbler (Early)

588	1401	EMPRESS 8 oz Tumbler H	635	1469	RIDGELEIGH Rd Cigarette Holder & Sq Ash Tray, 4 ea H
589	1401	EMPRESS 8 oz Tumbler D/F H	636	1469	RIDGELEIGH Sq Ash Tray, 6 ea H X
590	4002	AQUA CALIENTE Cocktail, Old Colony Etch, Sahara	637	1489	PURITAN 6" Sq Ash Tray, Krall Engraved Monogram
591	4002	AQUA CALIENTE Cocktail, Sahara	638	9 3/4"	Coaster, 3 ea H
592	3381	CREOLE 5 oz Ftd Soda, Sahara	639	1540	LARIAT 4" Coaster, 8 ea 1-X
593	351	PRISCILLA Goblet, 2 ea H	640	10	OAK LEAF Coaster, 12 ea
594	1E92	OMEGA Goblet, Melody Cut	641	1503	CRYSTOLITE Ash Tray Match Holder, Cut H
595	3389	DUQUESNE Goblet, Chintz Etch, Sahara	642	341 1/2	PURITAN Butter Cover H
596	3312	GAYOSO Goblet, Cherry Etch, 2 ea	643	341	OLD WILLIAMSBURG 5 1/2" Epergnette, Pr, H
597	5010	SYMPHONIE Goblet, Minuet Etch	644	1519	WAVERLY 6" Epergnette, Deep, Pr H
598	3344	CAROLINA Goblet, Osage Etch H	645	1519	WAVERLY 6 1/2" Epergnette, Cupped, Pr H
599	3320	RITZ Goblet, Pantograph Etch, Moongleam Ft	646	353	MED FLAT PANEL Cemetery Vase, Sun Purpled H
600		Pulled Stem Goblet (Verified as Heisey by Emmett Olson)	647		5 Lids - 1519 WAVERLY Bow Tie, Rose Etch; 1503 CRYSTOLITE Shell Candy; 1590 ZODIAC Candy; 1519 WAVERLY Tall Candy, Amber; 1519 WAVERLY Oval Lemon
601	3312	GAYOSO Goblet, Trefoil Etch, 4 ea 1-X	648		5 Lids - 1519 WAVERLY Choc Box, Rose Etch; 1951 CABOCHON Candy, Rose Etch; 1183 REVERE, Rd Lemon; 1590 ZODIAC Tall Candy; 1506 WHIRLPOOL Tall Candy, Limelight
602	4004	IMPROMPTU Goblet	649	1238	BEEHIVE 8" Plate, Moongleam
603	3390	CARCASSONNE Low Goblet, Moon-geam Ft	650	1236	EAGLE 8" Plate, Moongleam
604	5010	SYMPHONIE Low Goblet, Minuet Etch, 4 ea	651	1236	EAGLE 8" Plate
605	3380	OLD DOMINION Goblet, Sahara, 7 ea 1-X	652	1404	OLD SANDWICH 8" Plate, 8 ea H
606	1425	VICTORIAN Goblet, 4 ea 1-X	653	1225	COARSE RIB 7" Plate, Flamingo, 6 ea H 1-X
607	2351	12 oz Soda, Pied Piper Etch X	654	4182	8" Plate, Sea Nymph Etch
608	3480	KOORS 12 oz Ftd Soda, Moongleam Ft, 4 ea	655	1401	EMPRESS 8" Sq Plate, 3390 CARCASSONNE Goblet & Ice Tea, All Lotus Classic Etch, Sahara H
609	353	MED FLAT PANEL 8 oz Tumbler, Ft Wm Henry Etch H & 1485 SATURN 8 oz Tumbler, ULC Etch H	656	1252	TWIST 6" Plate, Marigold, Crazed, 6 ea H
610	1503	CRYSTOLITE Punch Cup H	657	1252	TWIST 6" Plate, Flamingo, 8 ea H
611	341 1/2	PURITAN 8 oz Soda H	658	1404	OLD SANDWICH 7" Plate 7 ea
612	397	COLONIAL RING 5 oz Ice Tea H & 3480 KOORS Soda, Needle Etch	659	1184	YEOMAN 6" Plate, 8 ea
613	1184	YEOMAN 8 oz Tumbler DO, 5 ea H X	660	1401	EMPRESS 9" Plate, Flamingo, 2 ea H X
614	1486	COLEPORT 8 oz Tumber, 2 ea H & 5 oz Tumbler H & 1506 WHIRLPOOL Juice H	661	1519	WAVERLY 8" Plate, Narcissus Cut
615	153	8 oz Tumbler H & 341 1/2 8 oz Tumbler, 2 ea H	662	1229	OCTAGON 6" Cheese DO, Sahara
616	4044	NEW ERA 2 Lt Candle w/Bobeches & Prisms, Sea Glade Cut	663	1184	YEOMAN 8" Plate DO, 12 ea
617	1235	BEADED PANEL & SUNBURST 4 1/2" Nappy, Crimped, Gold Dec, 4 ea	664	407	COARSE RIB 7" Plates, 18 ea H
618	116	OAK LEAF Floral Bowl & Candlestick, Pr, Flamingo H	665	1401	EMPRESS 8" Sq Plate, Sahara H
619	1405	IPSWICH Ftd Floral Bowl, Candle-vase & Inserts w/Prisms, Pr H	666	1401	EMPRESS 11" Floral Bowl D/F
620	427	DAISY & LEAVES 9" Vase	667	1401	EMPRESS Floral Bowl D/F, Moongleam H
621	325	PILLOWS Punch Cups, 4 ea H 2-X	668	7000	SUNFLOWER Floral Bowl & Candlestick, Pr H
622	1205	FANCY LOOP Punch Cup	669	1202	12" Floral Bowl & Base, Moongleam H
623	1503	CRYSTOLITE Punch Cup, 9 ea	670	1231	RIBBED OCTAGON 13" Platter, Moongleam
624	1508	Card Case w/Cutting	671	1191	9" Hld 3 Part Spice Dish, Hawthorne, Gold Trim H
625	1519	WAVERLY 6" Deep Epergnette, 2 ea H	672	1191	9" Hld Spice Tray, Moongleam H
626	366	Ash Tray & Match Stand, Flamingo H	673	341	PURITAN 13 1/2" 5 Part Relish H
627	365	Ash Tray, Cut Monogram	674	500	OCTAGON Ice Tub, Flamingo H
628	1503	CRYSTOLITE Rd Cigarette Holder H	675	339	CONTINENTAL 8" Low Ftd Comport H
629	1540	LARIAT Cigarette Box	676	1231	RIBBED OCTAGON 10 1/2" Hld Sandwich Plate, Hawthorne H
630	1503	CRYSTOLITE 4" Cigarette Box H & 3" Sq Ash Tray, 4 ea H 2-X			
631	1503	CRYSTOLITE 4" Cigarette Box H			
632	1533	WAMPUM Ash Tray, 2 ea			
633	1186	Ind Ash Tray, HVC Monogram			
634	1469	RIDGELEIGH Rd Cigarette Holder & Sq Ash Tray, 4 ea H			

677	416	HERRINGBONE 8" Soup, Flamingo 8 ea H	699	393	NARROW FLUTE Champagne, Hollow Stem, Gold Dec
678	1185	YEOMAN Hld Cookie Tray, Unk Cut H	700	5042	CORINTHIAN Champagne
679	1184	YEOMAN 10" Low Ftd Salver, Iridized w/Black Rim H	701	5010	SYMPHONIE Champagne, Minuet Etch
680	1185	YEOMAN Hld Cookie Tray, Cut, Signed Hawkes H	702	341	PURITAN Champagne, 2 ea H
681	393	NARROW FLUTE 2 Pc Cheese & Cracker, Gold Trim H	703	5024	OXFORD Champagne, Maryland Cut
682	1519	WAVERLY 6" Deep Epergnette, 2 ea H	704	150	BANDED FLUTE Champagne, 3 ea H
683	1503	CRYSTOLITE 2 Lt Candle, Pr	705	1405	IPSWICH 4 oz Champagne, Moongleam H
684	1469	RIDGELEIGH 3 Part Rectangular Relish, 2 ea	706	3368	ALBERMARLE Champagne, Moongleam Ft
685	301	Low Candelabra Base w/Metal Fittings	707	5009	QUEEN ANN Champagne, Belle-Le- Rose Etch
686	1540	LARIAT 12" Floral Bowl & 12" Gardenia Bowl	708	V8621	PINE CONE Bowl, Verlys by Heisey
687	353	MED FLAT PANEL 10" Spice Tray X	709	V8621	PINE CONE Bowl, Verlys by Heisey
688	1541	ATHENA 12" Gardenia Bowl	710	352	MED FLAT PANEL Large Spooner, Patent Dtd H X
689	1205	FANCY LOOP Wine, Emerald w/Gold (Fair)	711	1184	YEOMAN 8½" Oyster Cocktail, (Soup) Engraved Rim, 7 ea H
690	3357	KING ARTHUR Wine, Moongleam Stem H	712	1540	LARIAT Sm Candy Box, No Cover H
691	3370	AFRICAN Wine, Moongleam Stem X	713	305	PUNTY & DIAMOND POINT Electric Light Shade
692	3380	OLD DOMINION 2½ oz Wine, Empress Etch	714	1235	BEADED PANEL & SUNBURST Spooner
693	3389	DUQUESNE Wine, Everglade Cut	715	487	HEXAGON STEM Cologne, Iridized Lavender H
694	3389	DUQUESNE Wine, Continental Cut	716	1183	YEOMAN 5" Comport, Moongleam
695	1235	BEADED PANEL & SUNBURST Wine, Gold Dec	717	353	MED FLAT PANEL Toothbrush Holder, Blue Enam Dec, H (Rough Bottom)
696	5024	OXFORD 2½ oz Wine	718	1205	FANCY LOOP Pickle
697	3308	BOB WHITE 2 oz Wine, Peacock Etch	719	1495	FERN Twin Mayo & Underplate, Rosalie Etch
698	3404	SPANISH Wine, Florentine Cut	720	2401	Handled Ice Tea, 3 ea

MAIL BIDS WHEN BIDDING BY MAIL PLEASE FOLLOW THESE PROCEDURES:

Each mail bid is handled competitively; that is, we start at a reasonable level and bid only as high as necessary to buy the item or lot. Of course, each bid has to have a limit-set by you, the bidder-and we can't bid above that limit. Sometimes, due to the sequence of bidding, a competing bidder will hit the exact amount of the limit and win the bid. This is always frustrating, but an unavoidable part of the game!

To anyone who would like to submit one or more mail bids for the coming March Auction, we would like to suggest the following tips:

1. Lots containing multiple items (such as cream & sugar, set of goblets, pair of anything, console sets, etc.) are usually sold as "so much a piece, the set (pair, lot, etc.) to go". Therefore the final lot price will be a dollar multiple of the number of items in the lot, and a bid limit should be set accordingly. (example: a pair of candlesticks at \$20.00 each make a lot price of \$40.00).

2. There are minimum limits to raises that will be accepted in the bidding, depending on the price level of the item. These limits range from \$1.00 possible on an item under \$10.00 to \$25.00 or higher on items over \$100. Therefore a limit of \$10.25 is no better than one of \$10.00.

3. Multiple item lots are not normally split up, but sold as a lot to one bidder.

4. A separate check may be sent for each lot to be bid, or one check may be enclosed for the total of the maximum bids for several lots, but in either case, include a sufficient amount for shipping. Be sure to stipulate how much is the maximum bid for each lot and how much is for shipping. Any surplus from the bidding and/or shipping will be refunded.

5. Since HCA can accept BancAmericard/Visa or Mastercharge, we'll try something new this year. If you have either card, you may just send a list of maximum limits for each lot you wish to bid for, along with your card type, number, and expiration date. Then the total cost, including shipping can be charged to your account.

6. An "SASE" is requested to return unused funds and your letter giving the results of your bids.

7. The glass for all successful mail bids will be packed and shipped by UPS from the Administration Building. Therefore a complete street address is required. (No PO Box addresses, please).

Due to the large volume of mail bids, we will be unable to comply with special requests, such as calls to give results.

Only mint items will be bid on-if damage is noted on an item before it is put up for auction, we will not bid on it. In case of duplicate mail bids, earliest postmark will be given preference. Bids must be received by March 12. Mail bids to: HCA Auction, PO Box 42, Dayton, OH 45420.

You may call me at 513-299-4364 evenings or weekends (NOT COLLECT!) BOB JOHNSON

MOTELS IN THE NEWARK AREA

FACILITY:	LOCATION:	# UNITS:	RATES:
Buxton Inn-1812	313 E. Broadway Granville, OH 43023 (614) 587-0001	3	S - \$20 D - \$25 Suite \$37.50 (4 persons)
Duke's Inn Motel	I-70 at St. Rt. 79 (Buckeye Lake Exit) P O Box 1206 Buckeye Lake, OH 43008 (614) 929-1015	95	S - \$17.95 D - \$22.95 3 - \$25.95 4 - \$28.95
Granville Inn	314 E. Broadway Granville, OH 43023 (614) 587-3333	28	S - \$33.00 D - \$38.00
Holiday Inn of Amer.	733 Hebron Road Rt. 79 Heath OH 43055 (614) 522-1165	107	S - \$28 to \$29 D - \$33 to \$35 \$5 each additional person over 19 years
Howard Johnson's Motor Lodge	755 Hebron Rd. Rt. 79 Heath, OH 43055 (614) 522-3191 1-800-654-2000	72	S - \$29 to \$32 D - \$32 to \$35 \$6 each additional person
Midtown Terrace Motel	Church & Seventh Streets Newark, OH, 43055 (614) 345-9721 1-800-447-4470	37	S - \$18 D - \$19 to \$20 \$4 each additional person
University Inn	1225 West Church Street Newark, OH 43055 (614) 344-2136	36	S - \$16.95 to \$18.95 D - \$20.95 to \$23.95 \$3 each additional person
Sheraton Inn	50 North Second Street Newark, OH 43055 (614) 349-8411	127	S - \$32 to \$35 D - \$37 to \$40 \$5 each additional person
Star Lite Motel	Route 79, South 1342 Hebron Road Heath OH 43055 (614) 522-3207	19	S - \$13.72 D - \$16.88

Heisey Collectors of America, Inc.

P.O. BOX 27
NEWARK, OH 43055

Additions and Corrections to Gift Shop Sales List

48. #1560 VICTORIAN GIRL BELLE, available in milk glass, rose pink, sunshine yellow, light blue and light green (plain)..... \$8.00
 Light blue frosted, rose pink frosted, sunshine yellow & lt. green frosted..... \$9.00
 Marked IG...made in original Heisey molds by Imperial Glass Corp. exclusively for Heisey Collectors of America, Inc. 4-1/4" high.
54. STANDING COLT - SOLD OUT
67. PLAYING CARDS, Heisey Museum, Single deck\$2.20
 Double deck in plastic box..... 4.50
 If ordered with other items.
 If ordering cards ONLY, the price including Shipping is Single \$3.45
 Double \$5.75.
71. CYGNET (baby swan) Light blue. Marked I.G. 1280 made.....\$13.25

The cup plates in Amethyst and Teal Blue are in short supply. We will soon have the Fandango Cup Plate, probably in yellow. Watch for the announcement in Heisey News.

SPECIAL PURCHASE

We have purchased an overstock of crystal elephant handled baby cups from Imperial and are offering them at \$7.00 each while they last. The usual discounts will apply. The regular price is \$8.50. Include 10% for shipping. Ohio residents must pay 5½% sales tax.

DATES TO REMEMBER . . .

- | | |
|-------------|--|
| MARCH 13-14 | EIGHTH ANNUAL ALL-HEISEY BENEFIT AUCTION, OSU NEWARK
CAMPUS, COUNTRY CLUB DRIVE |
| MARCH 15 | FLEA MARKET, STARLIGHT SCHOOL 9 AM - 4 PM |
| MARCH 21-22 | NATIONAL CAPITAL HEISEY COLLECTORS ALL-HEISEY SHOW
& SALE |
| JUNE 18-21 | TENTH ANNUAL CONVENTION, NEWARK, OH |

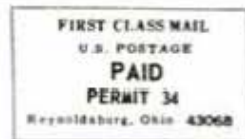

STARTING MARCH 1 MUSEUM HOURS ARE 1-4 PM DAILY EXCEPT SUNDAY AND HOLIDAYS