

HEISEY

NEWS

OFFICIAL PUBLICATION HEISEY COLLECTORS OF AMERICA

©Heisey Collectors of America, Inc. 1980
All Rights Reserved

VOL. IX NO. 7 JULY, 1980

ONE DOLLAR



*Arrangement
By Mrs. Dillon
for Heisey*

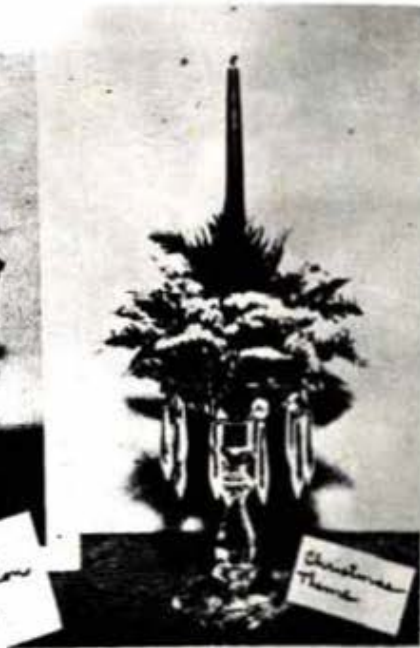

*Christmas
Theme*



*Flowers can be
fastened to candle
with straight pins*



*Lollipop and Candy for the kids!
(Looking they will love the candies)*

THE 1980 CONVENTION COMMITTEES

A great big thanks to everyone listed below for their outstanding contributions to the 1980 Convention. It certainly was one of our finest conventions so far and all of these people are responsible. Thanks also to all of those who helped in any way and who are not listed.

CONVENTION COMMITTEES

ROBERT G. McCLAIN.....GENERAL CHAIRMAN

SHOW

* Jack Metcalf
Virgil Hauser
Dick Spencer
Charles Wade

HOSPITALITY

* Miriam Balo
Vivian & Percy Moore
National Capital H.C.
Northern Illinois H.C.C.
The Heisey Hunters,
Newark, Ohio

PROGRAMS & TICKETS

* Robert G. McClain
Harley Bethel
Maureen Kovacs
Richard Marshall

DISPLAY

* Mary McWilliams
* Harley Bethel
Jean Johnson
Bill Johnson
Maureen Kovacs
Laverne Lokay
Virginia Yeakley

RESERVATIONS & REGISTRATIONS

Phyllis McClain
Robert G. McClain

'CAUCUS'

Heisey Heritage Society

SOUVENIR 'Oscars'

* Judy & Jerry Robinson
Virginia & O'Dell Johnson
Jay Barker
Bill Clifford

PUBLICITY

* Louise Ream
Robert Coyle
Debbie DeLaney
Helen Pallagi

'THE PARTY WORKERS'

* Helen Pallagi
Opal Blair
Frances Law
Christos Maskaleris

* Indicates Chairman

Thank you all!
Lrince

HEISEY NEWS — — — P.O. BOX 27 — — — NEWARK, OHIO 43055

EDITOR — LOUISE REAM, 1115 W. Main St., Newark, OH 43055
ASST. EDITOR — NEILA BREDEHOFT, Box 27, Newark, OH 43055
PUBLISHED MONTHLY — \$10.00/year — \$1.00/copy
BACK ISSUES AVAILABLE AT \$8.00/year — \$1.00/copy

PRESIDENT	LOUISE REAM	(614) 344-2377
VICE PRESIDENT	JACK METCALF	(614) 892-2664
SECRETARY	MARY McWILLIAMS	(614) 345-4380
TREASURER	LOREN YEAKLEY	(614) 522-5820

Heisey Collectors of America, Inc. is a non-profit corporation with tax exempt status. Owners and operators of National Heisey Glass Museum, 6th and Church Streets, Newark, Ohio. Open Daily 1-4 p.m., April through October except Monday and Holidays, November through March, Wednesday, Saturday, Sunday 1-4 p.m. Members admitted free.

Phone: (614) 345-2932. Club membership (includes 12 issues of Heisey News and participation in all club activities) \$10.00/Year plus \$1.00 each for additional family members in same household who wish a membership card. For voting membership add \$25.00, one time only fee, or write for information.

For Membership - HCA Membership, Box 27, Newark, OH 43055. Notify immediately of any change of address.

The opinions expressed in articles in Heisey News are those of the authors and not necessarily those of the organization. The Editorial Staff reserves the right to edit or refuse any material submitted for publication. When requesting information, please enclose a self addressed stamped envelope (SASE).

ADVERTISING — Send all ads to:
Neila Bredehoft, Advertising
Box 27
Newark, OH 43055

DEALER DIRECTOR ADVERTISING RATES — 5 line - \$6.00/6 issues

CLASSIFIED ADVERTISING — 5¢/word — \$1.00 Minimum. We cannot mix type sizes in Classified Ads. Abbreviations and initials count as words.

DISPLAY ADVERTISING	RATES	MEMBER	NON-MEMBER
	1/8 Page	\$ 8.00	\$15.00
	1/4 Page	\$15.00	\$25.00
	1/2 Page	\$25.00	\$40.00
	Full Page	\$45.00	\$60.00

PAYMENT IN FULL MUST ACCOMPANY ALL ADS.

Advertising copy reaching us by the 5th of the month will be in the next month's issue. Advertisements containing reproductions will not knowingly be accepted unless clearly stated (i.e. Heisey by Imperial, etc.) Heisey News assumes no responsibility for false advertising or misleading information. In the event of typographical error, the incorrect portion of the ad will be run in the following issue, but Heisey News assumes no further liability.

Send all letters and articles to be published to the Editor. Letters to columnists should be sent to the club address and will be forwarded.

FROM THE DESK OF LOUISE REAM

Well, it is all over for another year and we are trying to get back to normal, whatever passes for normal here. Visitors have been coming steadily since the Convention and everyone is amazed at the beauty of the Museum and the variety of the glass. We are fortunate that we have acquired two new docents this summer who are very faithful and give us a lot of help. One is Jane Brown of nearby Pataskala and the other, Roland Decker, a former employee, of Newark who comes often and helps in any way he can. We need an absolute minimum of two people every day and three or four is much better. We have made the tour self guiding by the use of a guide sheet and identification cards on almost everything so that volunteers do not need to stay away because they feel they do not know enough about the glass. We are in need of at least 2 people for the first Sunday of every month to help Dick Marsh who is in charge on that day. The job usually means taking care of the door or working in the gift shop.

We believe that most of the show dealers will be back next year but if you want to be on the waiting list please send your name to the HCA 1981 Show Committee, PO Box 27, Newark, OH 43055. I am pleased to tell you that the people at OSU were amazed at the professional manner that the show and display were done and are happy that we want to come back next year.

I have left the writing about the Convention events to Evelyn and Jim Jordan and you will find these accounts on pages 4, 5 and 6. Jim is a new member of the Board of Directors who lives in Lansdale, PA and is employed as a security engineer. He also is attending Temple University School of Business Administration, has served two years as president of the Heisey Heritage Society and writes a finds column for Diamond Dust, that club's newsletter. He is our new columnist for reporting your finds so please send your letters to him c/o the club address. He can't write the column without some input from the membership.

I must take this opportunity to thank Darrell Bratt, Charlie Wade and Virgil Hauser, retiring Board members, for their loyal support during the past four years. They have contributed greatly to HCA during that time. We also welcome the new members-Betty Wanser, Anaheim, CA; Jim Jordan, Lansdale, PA; Jim Kennon, Ohio and returnee Jack Metcalf. I was also reelected. The Board will meet on July 26 when officers will be elected.

As many of you know, Jerry Robinson was having problems with kidney stones all during Convention and we received word today (July 7) that he had undergone surgery in the past few days. Thanks, Jerry, for a job well done - and under great stress for the whole time you were in Newark. Hope you feel better real soon.

We mentioned in June's issue that the light blue Wings Up Mallard is in. Orders have been slow on this and it is really very nice. They are \$13.00 each with the usual 10% shipping and quantity discounts. See page 6 for this and other items for sale. Remember these help maintain your Museum. UPS rates have gone up and the shipping on small items is high for which we are sorry. We also have Oscars left for \$19.00 each plus postage. There is no discount on these. The Heather Oscar mistakes will likely be sold out before you get this and many of you may not get any. Your checks will be returned. The orders have just poured in. You do read your newsletter!

I'd like to mention that 1489 Puritan cigarette boxes are often marked under the rim of the lid and even sometimes in the center of the inside of the lid. I personally own two marked ones, one with Dolly Madison Rose cutting, the other decorated by Dorothy Thorpe. Remember, Never Say Never! And yes, Heisey did definitely make the Santa Fe etching and many more railroad etchings.

We were very pleased that Maureen Kovacs of Long Island, NY did the cover for our Convention program this year and also again made the beautiful and very professional posters for the display. Maureen is a commercial artist and we are glad to have her aboard. Bob Coyle made the poster which was the cover of last month's issue and it also generated a lot of favorable comment.

If any of you have any good black and white pictures of the Convention events we'd appreciate copies. We didn't have any back in time for this newsletter.

Ralph Riley, a professional organist who used to play for "Inner Sanctum" and who has made many appearances on Broadway was our organist for the Convention Banquet. We were surprised to learn that he had also worked at Heisey during his youth.

Christopher Ries of Columbus, Ohio, our banquet speaker is a very young and brilliant artist in contemporary glass. Several of his own works were on display and were outstandingly beautiful. Many people present felt that he is ahead of his time and were quite appreciative of the fact that, instead of merely copying earlier glass forms he has created an entirely different concept of his own. Made from absolutely perfect crystal his glass sculptures are prismatically ground and polished, with special effects created by etching, engraving or sandblasting or by carefully engineered fractures. The price of these ranged from \$700 to several thousand. It is impossible to describe them but much more will be heard from this talented young man, who already has sold many of his fine pieces to museums and elsewhere.

You will be getting your letter concerning the September 15 dinner as a separate mailing. Keep this date open.

Happy Collecting,

WATCH FOR YOUR LETTER ANNOUNCING THE DETAILS

Louise Ream

FOR THE SEPTEMBER SOUVENIR DINNER -3-

IN TRIBUTE

BY JIM JORDAN

If I have to choose one highlight of the Convention over all others, year after year it always remains the same: the Display. Granted, the sale floor is exciting with the fever pitch of the hunt, not to mention the flea markets and the swap meet, but they all pale in comparison to the Display. There, in that one room, voices are hushed, and many a lip forms silent "Ohs" and "Ahs" for it is there that the truly rare and beautiful are displayed in silent splendor.

Once a year, for a few magic moments, fellow collectors open their treasure chests for us all to see. How else (save at the Museum) can humble eyes ever hope to gaze upon a cobalt Victorian sherbet and goblet, or an alexandrite Colonial goblet and a Comet Leaf alexandrite goblet? Where else other than the Display have you ever seen a Mermaid etched ball vase in Alexandrite? How many of you have ever gazed upon a Touraine cake stand in opal, or four different sized custard bud vases in Winged Scroll? The sugar and creamer collection along with the tumbler collection were absolutely fabulous, and if you failed to see the magnificent candlestick collection, you denied yourself the opportunity to see something which does not pass your way too often.

The table settings in their kaleidoscope of colors brought envy to the mind, not because we personally didn't own them, but because they represent the way we were in days gone by. There was true beauty then, and perhaps that is what we are all trying to recapture in the present era of cheap substitutes.

For four wonderful days, the Display brought together buyer, seller, collector, and thirty-two Charter Clubs, all of whom left their separate identities at the door and entered a magic world where we were as one, looking upon that which binds us all together. It is a vision worth recalling from time to time.

Ed. Jim is a newly-elected member of the Board of Directors of HCA. Thanks, Jim, for the very nice tribute to our fabulous display.

* * * * *

CONVENTION 1980

BY EVELYN JORDAN

The sweet symphony of tires humming on long, white roads once again brought us to "Heisey Land." The Ninth Annual Heisey Convention was our objective and Newark, Ohio our destination. The Convention is held in conjunction with the Licking County "Land of Legend Festival" and spanned four wonderful days of buying Heisey, selling Heisey, talking Heisey, and meeting fellow Heisey enthusiasts (some of whom we never get to see any other time of the year) and reveling in the delightful experience of once again actually being on the spot where it all happened so many years ago. Nearly 5000 people attended the show, making it the largest gathering so far, 569 were registered for the Convention.

This year, the Antique Show and the Heisey Display were held on the Newark campus of the Ohio State University, an advantage which provided more than adequate parking and the ease of having the two great events at the same location. The grounds are lovely, and the buildings (Adena Hall used for the Show and Hopewell Hall for the Display) are air conditioned and comfortable.

The Show did not open until 12:00 noon on Thursday, giving HCA members ample time to make their first trip to see the Display and to pick up their souvenir Oscars for this year, the plug horse in a purple color (Heather) which made the fourth of the series being offered. Almost 2400 were pre-sold. Because it is a limited edition, only a few are left to be sold at the Museum and they are sure to go quickly. Jerry Robinson (and family) took the responsibility for handling the Oscars this year, and he said he had calculated that he had spent at least 551 hours on the project from February 7th to June 19th when the Convention opened. A tremendous job, well done.

This year's Convention theme was "For the Eighties - Elect Heisey Your Collectible" - there were no dissenting votes to be heard. Long, red, white and blue banners decorated the walls of both halls at the campus and of the banquet room of the Sheraton, which was used for several events, as well. Each booth at the Display added to the theme. As you entered the room, the first booth proclaimed "In Your Heart You Know Heisey's Right" which contained an unusual and diversified array of Heisey items from the "Land of Heisey Society" in Newark. There were thirteen booths in all and each seemed to outshine the others as you stood in front of it.

"Heisey's Colonial Candelite" a truly handsome collection of early candlesticks and candelabra was presented by Tom Felt and Bob O'Grady.

"Tumblers for any Party" were featured by Tom and Neila Bredehoft. A tumbler collector's dream, it contained all colors and patterns from all periods.

"Winged Scroll" was shown in crystal, custard and emerald. A lovely display by Linda and Huncie Hemberger.

"Blue Ribbon to the Winner" was presented by the Diamond H Study Club. It was done in cobalt and crystal and three Heisey elephants and three donkeys vied for the first place "blue ribbon" in the booth.

"Old Flames" turned out to be an exciting arrangement of ruby stained pieces. Never did I realize the variety and delicacy of some of the rare stained items that were shown by Mr. & Mrs. Al Miller.

"Orchids to the Winner" by the Newark Heisey Collector's Club contained examples of crystal Orchid etched pieces and alexandrite, a handsome combination with live orchids gracing the tables.

"For a New Twist, Support the Heisey Party" was the name chosen by the "Heisey 76'ers" depicted by the attractive Twist pattern in flamingo.

"Dawn of a New Era", the Bay State HCC's offering had the sleek New Era pattern, of course, in crystal, dawn and cobalt. Striking!

"Victory is Sweet" was the theme of the booth decorated by George and Eileen Schamel, and such a display of creamers and sugars has surely never been seen before. They marched across the front of the display floor in grand style.

"Cast a Vote for Your Favorite" was the most unique setting. The Dayton Area HCC used campaign slogans to effectively identify their booth. Among the slogans were, "A Chicken in Every Pot" demonstrated by a Heisey chick coming out of a tiny iron pot, and "Straw Votes" with a Heisey straw holder to collect them. Authentic campaign buttons, and a ballot box complete with pencils and paper ballots made voting easy.

"Red, White and Blue" the display put on by the "Heisey Hunters of Newark" was beautifully coordinated in those striking colors: red stained, opal and cobalt filled the bill. A straw hat and live flowers topped off the booth.

"We Toast the Victors" was depicted by decanter sets, wines, champagnes, and a Beaded Panel and Sunburst punch bowl and cups. Electoral posters, a straw hat and ample bunches of grapes were added to lend charm to the display. This effort was by the Reynoldsburg HCC.

Two glass cabinets of the rarest and dearest little miniatures was one of the main attractions in the room, entitled "Heisey's Little Things Get Our Vote" it was presented by the "Far East Heisey Club."

In the center of the Display floor were 13 tables set with services of Heisey in different patterns and colors. Each table was exquisitely arranged with a centerpiece of lovely flowers, individually picked to accent the color and style of glass being used. Greek Key in crystal was on the center table, and on the other tables around it were Creole and Empress in alexandrite; Spanish and Empress in Tangerine; Yeoman and Saturn in limelight; Spanish, Empress and Thumbprint & Panel in cobalt; Twist in Marigold; Pleat & Panel in flamingo; Lodestar, Saturn and 341 in Dawn; Carcassone and Empress in crystal with the Olympiad etch; Trojan and Yeoman in Hawthorne; Empress and Carcassone in Sahara with the Old Colony etch; Suez, Cabochon and Crystalite in Amber; and last, but certainly not least, Old Dominion and Yeoman in Moongleam with the Empress etch. For those of us who see and live Heisey every day it was superb, but for those new initiates and for visitors not at all familiar with Heisey, its excellence and variety, it was breathtaking.

The Museum hours were extended so that everyone had plenty of time to enjoy the treasures there, and partake of the punch and home-made cookies which were offered to all who visited. In addition to the Show and the Display, there were continuous events for the entertainment and education of Heisey lovers, from the newest to the most knowledgeable.

The "Great Debate" was a time for the experts to demonstrate their expertise. The morning was started with a continental breakfast after which the candidates for the 1980-81 Board members were introduced by Mary McWilliams, Chairman of the Nominating Committee. Bob McClain, the Convention Chairman then introduced our panel. In order of their appearance, they were Dick Marsh, Lynn Welker, Joe Lokay, Hank Pugliese, Louise Ream, Neila Bredehoft, Virginia Yeakley and Betty Wanser. Each piece of glassware brought by a curious spectator, was examined and identified as closely as possible. Although the maker of every piece could not be precisely pinned down, many questionable pieces were determined to be (or not to be) Heisey and somehow, that's what everyone really wants to know. The panel then had a question and answer period, and it's amazing what experts they really are.

The "Caucus" was held. It was actually a swap meet to which participants brought their duplicate Heisey items (or items they could bear to part with) to trade for something they wanted more. Over 200 people attended this event (the most ever) and many a good swap took place as trading was very active and faces were shining with big smiles as the traders left.

The HCA's own movie, "The Heisey Glass Story" was shown several times at the Sheraton telling the story of Heisey Glass, and the history of the HCA and the Museum. A "must" for every Heisey collector. There was a meeting of the Study Club Officers at the Sheraton and three fascinating seminars to add to our knowledge. They were: a lecture "The First Five Years of Heisey," and two slide shows, "Heisey by Imperial" and "Fakes and Reproductions of Heisey and Other Misleading Glass," subjects in which we are all extremely interested. There was "The Party Workers" get-together, a time when you could meet with former Heisey employees. "The Victory Party", the banquet, was held before the election of officers, but as our collectible, Heisey Glass, was definitely a winner all the way through, it was very appropriate. The Master of Ceremonies, Odell Johnson introduced our guest speaker, Christopher Ries who gave a very interesting slide lecture on the "History of Glass Through the Ages." Examples of very ancient and very rare glass were shown from the very beginning of glass-making through the ages right down to the speaker's own creations of today. It was surely an entertaining and enlightening affair.

(continued)

Although the Convention continued right on through till Sunday evening, the culmination for many of us was on Sunday morning, "Election Day" at the breakfast, Annual Business Meeting and election of the new Board members. The winners were Louise Ream, Betty Wanser, Jim Jordan, Jack Metcalf and Jim Kennon, a nominee from the floor. It was an exciting election and a rousing cheer followed the announcement that young Jim Kennon had taken the vote right there before our eyes. We offer congratulations to all the candidates, thanks to those who are retiring from the Board, and good luck to the new members and to the entire Board.

For me, it was the greatest Convention ever. Congeniality reigned, friendships were reaffirmed, the spirit of "working together" dominated the affair. Even the trip home seemed easy, and the next trip back too far away.

May, 1943, Crockery & Glass Journal

Here's how Heisey's "War Time Salesmen" save YOU time and trouble

REALIZING that war time conditions call for unusual solutions, Heisey developed four "War Time Salesmen."

Briefly, they are brochures, one each on the Crystolite and Lariat Patterns, Orchid Etching and Gift Items. There is a photograph of every item, each one is numbered, priced, and there is a column for checking the quantity needed.

All you need do is check your stock of each of these patterns, enter quantities needed in proper space, fill in your name and address, seal, stamp and mail to Newark. They are even self-addressed.

Then when the crystal arrives in your store, the "War Time Salesmen" enable you to identify and price each item correctly, even with "green" help. See how easy it is to keep up your stock?

Take a tip from the thousands of stores already using them—all enthusiastically, too. If you're not already using them, write TODAY for a complete set.

A. H. Heisey & Co., Newark, Ohio.

HEISEY'S
HAND-WROUGHT  CRYSTAL

DATES TO REMEMBER...

- SEPTEMBER 13 - Mini Show at Reynoldsburg, Ohio High School
- Annual Souvenir Dinner at Stoney Creek Country Club, Reynoldsburg, Ohio
- SEPTEMBER 27-28 - Bay State's All-Glass Show at Sturbridge, Massachusetts. See ad in this issue.

ITEMS NOW AVAILABLE

- WINGS-UP MALLARD, Light Blue
First of a series of three - \$13.00 each plus \$1.30 shipping.
 - PAIRPOINT CUP PLATE, Teal Blue HORSE & RIDER
\$5.50 plus 55¢ for shipping.
- Ohio residents please pay 4½% sales tax.
10% discount on \$50.00 and over,
25% discount \$250 and over.
MasterCharge and Visa accepted. Please include your number and date of expiration.

NEW FROM THE GIFT SHOP...

- PLAYING CARDS. Prices include shipping.
Single Deck - \$3.45
Double Deck - \$5.75 in plastic box.
Shipped UPS. Red or blue border - double decks have one of each.



INTERESTING LETTER TO THE SALESMEN

This letter gives some insight into the problems of the war years. L. R.

"January 15, 1943

Gentlemen:

The best Pittsburgh Show in its history has just been concluded. We are sorry that all of you salesmen were not in attendance so as to get a bird's eye view of what happened. All of the men were there with exception of four. This letter applies particularly to you four who were not there.

The buyers came to Pittsburgh with their order books and left orders. Some tremendous orders were placed and I am pretty sure that we got our share of them. Irrespective of inventory control and war conditions, we are going to have a big year, providing the government does not arbitrarily clamp down on our production.

Our plans for the coming year will continue to be placing all our efforts on Crystolite, Lariat, Orchid, our better figurines and table decorations. We expect to give you within a short time our Advertising Program and Publicity. This has been delayed until we found what the reaction at Pittsburgh would be, so we are now going ahead with our plans.

In order to promote these patterns, we have worked up a WAR TIME SALESMAN'S ORDERGRAM * in which is illustrated and identified every piece in the above mentioned patterns. Full particulars on these War Time Salesman's Ordergrams will go out to you just as soon as we receive the material from the printers. We expect to have this in your hands in ten days. I think you will find they will be one of the best business-getter ideas that have been put out by anyone. We showed this Ordergram to many buyers and they are all very enthused about it.

So that we can make the War Time Salesman Ordergram function properly it is imperative that each and every one of you make up a list of your customers who use Lariat, a list of those who use Crystolite and a list of those who use Orchid. Each list must be put on a separate sheet of paper. In other words, we want to have a complete list of every one using Lariat, Orchid and Crystolite. After these lists are compiled, it will not be necessary in the future to have you send us lists as we have in the past when we had advertising material and table cards to go out. However, YOU MUST BE SURE TO KEEP THESE LISTS UP TO DATE. All information and plans on this set-up will go out in another letter but we are anxious to get these lists as soon as possible.

On another letter which we are enclosing, we have given names to old patterns that were not named and have named all the new cuttings. We think you can do a constructive job by ordering all the patterns by name. In other words, when you write up an order for Crystolite, write it up as usual only put in the word "Crystolite" by the item. It will be billed this way to the customer. In this way, we will continue to keep these particular names before the customer.

We will also, have a new Lariat folder in the near future. It all depends on the printer. You can continue to order Crystolite and Orchid folders as needed. We still have quite a supply of the Gift Folder too. These are still good if used.

We had considerably good reaction on our new #5042 ** stemware line. This line is one of the nicest lines on the market. We have quite a few band cuttings that are all right but in a short time you will have some additional cuttings on this shape which we think will be salable.

We are also, flirting around with color in this line. We found considerable reaction towards color at the Pittsburgh Show. More information on this will be coming out soon. If any of you have some suggestions on color, we will be glad to have it. We are considering putting a light shade of Alexandrite in the foot of the Orchid stemware. Also, knobs, handles and a touch of color on the other flat pieces. All the boys at Pittsburgh thought this has big possibilities. A very light blue color was suggested. Also, our old Zircon. Comments and suggestions on these colors will be appreciated, and we would like to get your ideas on color as soon as possible--as to whether you want it or you don't want it.

After all our preaching and writing about keeping orders confined to items in your price list, we still note that many of you are putting old cuttings on new shapes and adding etchings to new items and vice-versa. This cannot be done in these times of labor and material shortages. Now if you do keep this up, we are going to return all orders that have these things on them to you to be re-written. This is the final word on this matter. We are always anxious to have your suggestions that we should have new items in our patterns and will do our utmost to supply those needs but you cannot get etched plates and other equipment *** so things like this only tend to clutter up our Shipping Department and cause a lot of grief and misunderstanding everywhere.

Our new #1559 Specials which have been named "Columbia" (The Gem of the Ocean) were liked by most everyone. Your samples are quite heavy and we are getting a new plunger to make them lighter in weight. Therefore, if your shipments are delayed a week or so, this is the reason. There will be TWO DIFFERENT SHAPED CANDLESTICKS in this Special. One with the STANDARD FOOT on it and the other with a SAUCER CUPPED foot. With these two sticks you can make up various combinations and work out sets that you can sell two in a town.

(continued)

We don't know how long these Specials will be in the line. It all depends on future business. They might have to be withdrawn any time. Therefore, all old Specials are withdrawn. We had hoped to make a new etched console set as a Special but it was impossible to get new plates. Hence, the only Special that we will have at present will be the new #1559 Columbia. A few orders were written in Pittsburgh for the old Etched Specials and these will be shipped, but we will not accept any more new orders for same.

The Columbia Specials will be sold in minimum quantities of 1 dozen of any one item. One dozen will be packed in a carton, so make your orders by dozens. Some of you fellows still send in orders for 1/3, 1/2 and 1/4 dozen #1553, after we broadcast at least one dozen times that one dozen was the minimum quantity. No orders for the Columbia Specials will be accepted in less than one dozen quantities of any one item.

We have a new cut prism which will be named "R" prism. This is a prism that has been used by Duncan's and Cambridge. It will be the same price as our "A" prism. This "R" prism is particularly good on our Colonial sticks and candelabra. We still have a few "A" prisms but we should confine all future orders for "A" prisms to our #4044 Candelabra as the "R" prism is a bit large for this stick. You can continue to sell the "H" and "P" prism on all candlesticks.

We also, have adopted a new plastic salt top. We do not have samples as yet, but they are on their way and the price of this plastic top will be the same as our #7 glass top. Samples of the "R" prism and the plastic Salt Top will be sent in the near future.

As I wrote you in the Fall, we cannot get a metal top for syrups, salts or what have you and the only way these can be provided is to have the customer give you a high priority rating.

We are enclosing a list of the recent Lariat Sales Contest Winners and have given consolation prizes to all who participated. Some of the salesmen requested that the prize checks be sent to them direct so they could present them to the winners and this is being done.

We do not have our final 1942 figures on your respective shipments. As you know, there was a Blind Bogey sales contest last year and the prizes will be awarded just as soon as the figures are completed. We may be forced to delay giving additional diamonds due to the terrific increase in the cost of these stones until after the war. There will not be many awarded, I can grant you that, but several will get them. Unless you hear from me, keep your pins.

As to 1943, this year is going to be most difficult to predict and it seems to me will be most unfair to a lot of you to set rigid quotas and carry on a contest that would be fair to all. However, something is going to be worked out that will be interesting and we will give you the dope soon.

Under the new WPB ruling for cardboard and carton manufacturing, our gift box situation is very uncertain but we will continue to pack those items we have packed last year in gift cartons at the same price until further notice. Don't ask for any new items to be packed in gift cartons. If conditions ease up, we may adopt some new ones for the Fall items.

We have quite a few nice things to be completed, but the mould situation is very difficult. Mould makers are as scarce as hen's teeth. As far as I can find out, I visited most of the important rooms in Pittsburgh, there is very little new to be offered. We had about as many new things as anyone.

I might suggest that some of you not overlook our #4004 Polka Dot stemware. Several salesmen have done very well with this line and placed it in the better high grade jewelry stores and china stores. It is not a particularly good department store line.

Many of you fellows are also overlooking our #4044 stemware. This line retails in most any type of store. It is the best modern line on the market. Our figurines and table decorations are still tops. So you can't go wrong on having your customers keep them in stock. Your new Ordergrams will be a great help in identifying and ordering these new figures.

Most of the fellows in Pittsburgh had a nice reaction on the #5042 Corinthian stemware line without decoration. The line is completed and the Saucer Champagne and Cocktail bowls are being worked. Without question, this is going to be a nice line.

There are several other new pieces in Orchid etching, such as, the #1540 Swing Vases, handled baskets, R. E. Mayonnaise, Crimped Vase and possibly the fan vase. Plates have been ordered for these items. We cannot promise you definitely when we will get them but we hope to within the next month.

Travelling is going to be difficult this year, and we are going to have to do a lot of direct mail and personal writing. If our customers will keep their best patterns stocked up, we are going to do about all we can handle. We have a lot of nice material to assist you in this work and we hope that you will take advantage of it and use this material constructively. There will be more information coming to you in the near future, but this is a synopsis or the highlights as things now stand.

The most important thing in this letter is to get your master War Time Salesman lists in on Orchid, Crystolite and Lariat patterns.

Rodney C. Irwin, Sales Manager

(continued)

P. S. Salesmen - January 15, 1943

On November 11, 1942 we advised you that cuttings #943 (Belfast), #944 (Courtship) and #945 (Virginia) were discontinued from that date on and that matchings would be taken care of until January 1st, 1943. Matching will be continued indefinitely but in doing so, it is distinctly understood that you will not accept any new accounts for these three patterns. No shipments will be made for these cuttings unless they are matchings for old customers.

R. C. I.

* See HEISEY NEWS 11/77, 12/77, 1/78
** 5042 Corinthian
*** Because of the War.

* * * * *

We're pressing to keep you from pressing us



(Ad from November, 1943 Crockery & Glass Journal)

WE could go ahead and tell you a long story about our manufacturing problems. Like everyone else in the industry, we have them—in abundance.

Shortage of help—shortage of some materials—oceans of orders . . . that about covers it. But it is mainly shortage of help.

This condition means that we are in a particularly bad spot on all types of blown ware, cut and etched ware, because that takes more time and work to produce. We might as well call a spade a spade and urge that you concentrate on pressed ware such as Crystolite and Lariat. We can make them faster and give you better service.

We are doing our best to fill your orders, but in times like this, we are all behind the eight ball.

A. H. Heisey & Co.



NEWARK, OHIO

A NEW INVENTION

In the past much conjecture on the way handles were attached on the 1229 Octagon pattern illustrated with the mold can now be put to rest. Included in the five notebooks full of copies of original Heisey patents obtained for the HCA by Tom Felt and Bob O'Grady, members of the Archives and Research Committee, is the patent for forming of handles as the glass vessel is being made.

One story I had heard about the handles, and certainly did not believe, was that when Heisey ran out of handles they jumped on the interurban to Cambridge and brought back a lot of handles from the Cambridge Glass Factory. The dealer had a light blue cheese plate and was trying to sell it for Heisey's experimental blue. It did look a little like 1229 but the handles were not right and he gave me the above explanation. I hope that no one fell for this. Anyone who knows anything about making glass knows that this would be impossible and that the handle had always been a part of the item and not attached after making.

It is interesting to learn that Heisey apparently was a forerunner in making this type of handle which apparently was used thereafter and was cheaper than having a highly skilled "Handler" attaching the handle after it was made. (While still hot and not yet firm, of course.)

Ray C. Cobel, the head of the mold shop must have been a genius in the methods of glassmaking as many patents were granted for his designs. He is generally known to have been one of the most valuable employees of the Heisey Company.

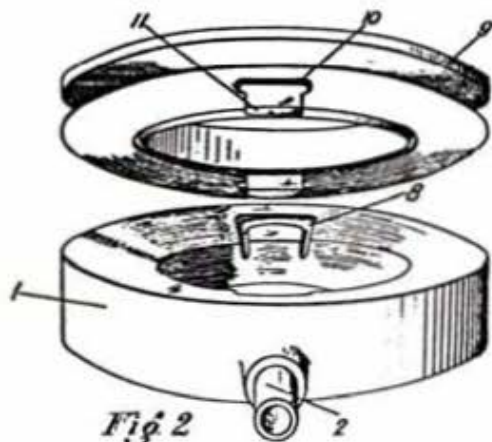
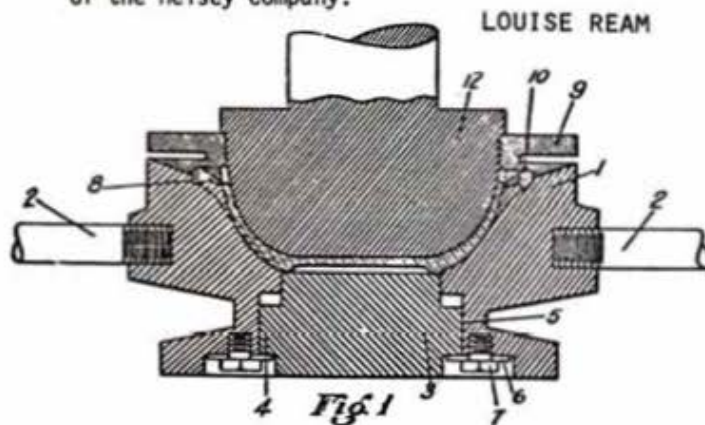

INVENTOR,
Ray C. Cobel.
BY
Edwin J. Cobel
ATTORNEYS.

1,774,871

My invention relates to method and apparatus for making articles of glassware and, more particularly, to method and apparatus for making articles of glassware, such as dishes or the like, that are provided with suitable handles.

Heretofore, it has been customary to make handled glassware, such as dishes or the like, by forming the article by any of the well-known methods, for instance pressing, and then attaching and shaping the handle by hand.

The attachment of handles to glass articles by the hand method is a slow, laborious and, consequently, expensive operation, requiring workmen of a high degree of skill. In addition to this, such method has practically precluded the idea of making glassware having handles thereon of such shape and designs as to add materially to the ornamental effect of the ware.

Making handled glassware, such as dishes or the like, by forming the body portion and then attaching and shaping the handle has had the added disadvantage which results from attaching two pieces of glass together when such pieces of glass are at different temperatures. A perfect weld is seldom, if ever, formed between the pieces of glass under such conditions and, in glassware having handles thereon, this has increased the possibility of the handles breaking away from the body portion of the article.

One object of my invention is to provide a method and apparatus for making glassware, such as dishes or the like, having handles thereon whereby the handles are formed integrally and simultaneously with the body of the article.

Other objects of my invention may be seen in the following description, and the preferred embodiment of my invention may be seen in the accompanying drawings wherein similar characters of reference designate corresponding parts and wherein:

Figure 1 is a vertical sectional view of a mold and plunger constructed in accordance with my invention.

Figure 2 is a perspective view of a part of the main body portion of the mold and the

(continued)

UNITED STATES PATENT OFFICE

RAY C. COBEL, OF NEWARK, OHIO, ASSIGNOR TO A. H. HEISEY & COMPANY, OF NEWARK, OHIO, A PARTNERSHIP

Sept. 2, 1930. APPARATUS FOR MAKING ARTICLES OF GLASSWARE

Application filed April 17, 1928. Serial No. 270,754.

mold ring which I employ, these parts being shown separated.

Figure 3 is a perspective view of a finished article that has been formed in my mold.

Figure 4 is a perspective view of a part of the article shown in Figure 3.

Figure 5 is a perspective view, partly in section, of a portion of the main body portion of my mold showing a mold ring assembled therewith.

Referring to the drawings, I have shown a press mold of the block type comprising a main body portion 1. This main body portion 1 is preferably provided with suitable handles 2 for convenience in moving the mold from place to place and for other reasons which will hereinafter appear.

Disposed in the lower part of the main body portion 1 is a valve 3, which valve preferably forms a substantial part of the bottom of the mold. Such valve has an annular flange 4 thereon fitting within a cutaway portion 5 in the base of the main body portion of the mold. The valve may be entirely removed from the main body portion 1 by removing the annular plate 6 which is secured to the main body portion by the screw bolts 7 or other suitable means and forms the lower wall of the annular groove 5. As will be seen by referring to Figure 1, the valve 3 is ordinarily in its lowermost position.

Referring to Figures 1, 2 and 3, it will be seen that the upper part of the main body portion 1 is provided with indentations 8 on its inner surface which are of the same general contour as the underside of the handle of the article which is to be formed in the mold. A mold ring 9 that is adapted to fit upon the top of the main body portion of the mold has indentations 10 in the surface thereof which are complementary to the indentations 8 in the main body portion when the two are in assembled relation. Lugs 11, depending from the mold ring 9, are designed to rest upon the inner surface of the main body portion adjacent the indentations 8. When in this position, they are complementary to the indentations 8 and 10.

In the operation of my device, a charge of molten glass is placed in the main body portion 1 of the mold and the mold ring 9 is positioned on the mold. When the mold ring 9 is in cooperative relation with the main body portion 1 of the mold, the indentations 8 and 10, together with the lugs 11, form a handle-shaping cavity into which glass is to be forced by the action of the plunger.

With the parts in this position, a plunger 12 is placed in the main body portion of the mold in the manner shown in Figure 1 and pressure exerted thereupon. Pressure on this plunger will cause the molten glass in the main body portion of the mold to flow upwardly around the plunger to form the body of the article and into the depressions 8 and 10 to form the handle. When the molten glass has become slightly cooled and has set sufficiently, the plunger may be removed,

the main body portion inverted and the valve 3 operated to push the article out of the main body portion of the mold. The article may then be subjected to the usual finishing operations, such as bending the handles to any desired angle.

Referring to the preceding description and the drawings attached hereto, it will be apparent that I have provided a method and apparatus for making articles of glassware having handles thereon wherein the handles will be formed simultaneously with the forming of the main body portion of the article and integrally therewith. Such method will not only permit the making of handled glassware wherein the handles may be of such shape and design as to add materially to the ornamental effect of the ware but will make possible the production of glassware wherein the handles have greater strength.

Having thus described my invention, what I claim is:

1. An apparatus for making an article of glassware with a handle thereon comprising a mold and a mold ring, said mold and mold ring having indentations therein designed to completely form a handle with an opening therein.

2. An apparatus for making an article of glassware with a handle thereon comprising a mold and a mold ring, said mold and mold ring having complementary indentations formed in the abutting surfaces thereof to form a handle, said abutting surfaces contacting with each other both outside of the handle and within the handle.

3. An apparatus for making articles of glassware with a handle thereon having an opening therethrough which comprises a mold and a mold ring having complementary indentations formed in the abutting surfaces thereof to form the handle with the opening therein, such abutting surfaces being free from interfitting projections.

4. An apparatus for making an article of glassware with a handle thereon comprising a mold and a mold ring, said mold and mold ring having complementary indentations formed in the abutting surfaces thereof to form a handle, each of said indentations forming substantially one-half of said handle.

5. An apparatus for making an article of glassware with a handle thereon comprising a mold and a mold ring, said mold and mold ring having complementary indentations formed in the abutting surfaces thereof to form a handle and such abutting surfaces being free from interfitting projections.

6. An apparatus for making an article of glassware with a handle thereon comprising a mold and a mold ring, said mold and mold ring having complementary indentations formed in the abutting surfaces thereof to form a handle with an opening therethrough, said indentations being of such form that the removal of the ring from the mold will leave the top and a portion of both the inner and outer sides of the handle exposed.

In testimony whereof I hereby affix my signature.

RAY C. COBEL



Fig. 4

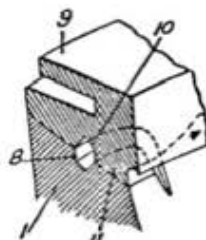

Fig. 5

AN ORIGINAL FACTORY PICTURE



TOP: Left to Right: 1951 Cabochon square relish and cake stand. 1458 snack plate with 5082 Mid Century cocktail. 1630 Stacking tumbler and 1951 ¼ lb. butter.

LOWER: Left to Right: 6000 Celestial 11 oz. Hiball and 4 oz. cocktail. 4004 Impromptu beverage, goblet and ball jug.

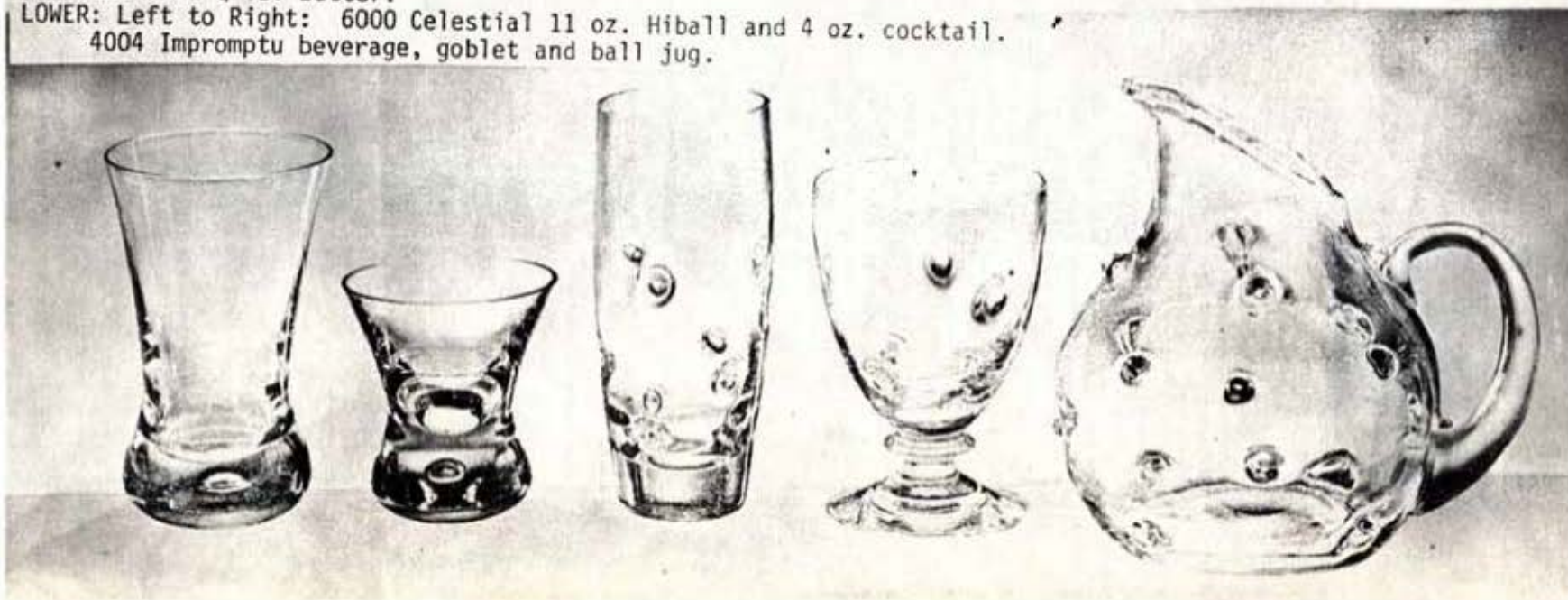

I have what I believe is a footed punch cup in the 1401½ Empress pattern. A photograph I took of it is shown with this article. Let's compare the design features of this footed punch cup with that which I will call the regular punch cup. On the regular 1401 punch cup, the four "Fleur de Lis" or lily designs are located at the edge of and equally spaced around the rim. Your lips will touch the lily design when taking a drink. In the case of the footed punch cup, there is a plain band about ½" wide around the top of the cup. The four lily designs are located at the lower edge of this band. Thus, in this case, your lips will not contact the lily design when a drink is taken. Note that the plain band flares in or as some call it, cups in, slightly. I have been told that if the rim (band) flares out rather than flares in, the item is then called a footed coffee or tea cup. There is a vertical row of glass dots under each lily on the regular punch cup while there are no dots on the footed punch cup. The handle design is the same for the regular and footed punch cups. The footed punch cup is about ¾" taller than the regular cup. The footed cup has a volume of 4½ oz. and the volume of the regular cup is 4 oz. The foot of the punch cup is circular and about 2¼" in diameter.

The regular punch cup was made in crystal, flamingo, moongleam and sahara. My footed punch cup is in crystal. There is no evidence that the footed punch cup was made in color.

My cup has a weak diamond H in the center of the bottom on the underside. It appears that the footed punch cup was only made for a few years in the early 1930's.

Ed. Note: There is one of these cups on display in the Museum, a recent acquisition. See the regular cup in the March issue of Heisey News.



EMPRESS 1401½ FOOTED PUNCH CUP

REFERENCE BOOK UPDATE

1421 HI-LO handled vase - Known cobalt crystal and sahara. Moongleam available. Marked.

1420 TULIP vase - Known sahara, flamingo, moongleam, cobalt, crystal. Marked.

21 ELECTRO PORTABLE known crystal, flamingo, moongleam (very dark, looks like emerald). Marked.

3440 stemline was named PORTSMOUTH by Heisey. Flamingo, moongleam, unmarked.

3386 DIAMOND ROSE comes in marigold, cobalt, crystal, moongleam and flamingo and possibly sahara. Marked.

Page 80, Burns blue book, the item in center is actually a 3389 DUQUESNE goblet. Made in crystal, sahara and tangerine. The information is wrong and belongs beside the picture at bottom of page 79. They have been reversed. L. R.

QUESTIONS & ANSWERS..

Q. I bought at a flea market a clear jar 6½" high, 2" opening, sides paneled with the following mark in the glass "Rennault". On the bottom is a mark - obviously Heisey in a circle. I have not seen it before. Can you tell me something about it?

- B. K., PA. 

A. This mark is not a Heisey trademark. The mark is currently used by the Owens-Illinois glass company of Toledo, OH, who make commercial glass containers.

Instead of a Diamond H, the mark is actually an I within a diamond. Close observation reveals that the "legs" on the letter are much too short to be an H. Also if it would be an H it would be placed 90° off the usual placement of the Heisey H in a Diamond.

Often the container bearing this mark also has the word "Duraglas" in script on it. The Diamond I was originally used by the Illinois Glass Co. of Alton Illinois from 1915. They also used it on bottles, fruit jars, etc.

Heisey did not make commercial bottles.



Illinois Glass Co., Alton, Illinois 1915 Blown

FOUND AFTER CONVENTION . . .

FOUND-A listing of ash trays on 4 sheets of yellow legal size paper. Write Att: L. Ream.

HAVE YOU THOUGHT THESE WERE MADE BY HEISEY?

BY LOUISE REAM

For years most of us had thought that these colognes were made by Heisey. A couple of years back we were privileged to see an early Duncan catalog (from the period the company was owned by A. H. Heisey and James E. Duncan) and there they were. This June we were able to get a copy of the catalog page showing the colognes. It is interesting to note that no other items in Pillows pattern appeared in this catalog. It is also interesting that there are no pictures of colognes in Heisey catalogs and no mention of them in Heisey Price Lists. Therefore we must assume that all of them were made at George Duncan Sons since we have no proof at all that they were ever made at Heisey. Thanks to George Fogg and Frank Maloney for the use of their catalog,

HEAVY PRESSED COLOGNE BOTTLES.



DUNCAN'S # 308

BY LOUISE REAM

Duncan also made a pattern very similar to Victorian. Many people mistake the oil bottles and the water bottle for Heisey. Victorian as a pattern came out long after the water bottle was out of vogue in glassware service. There are differences in the oil bottles. Note that the Duncan handle is rounded at the top while the Heisey one is nearly straight across. This is a poor copy of the Victorian oil but is the best I can find. Duncan made these oils in several sizes.



DUNCAN'S #308



No. 308-4 oz. OIL

HEISEY'S #1425
VICTORIAN



3 oz. Oil Bottle & No. 17 P. 5

"HEISEY'S POLO PLAYERS"

- #1 Sport Plate Etching
- #495 Polo Player Silhouette Etching
- #498 Modern Polo Player Silhouette Etching

Heisey produced 3 etchings using the game of polo as a motif. The idea was apparently popular and probably an attempt to capture a portion of the glassware market of the class of persons who indulged in the sport. None of the three are exactly common and thus all quite desirable to collectors.

The first polo etching was called simply #1 Sport. This seems to be a forerunner of the many sports-oriented etchings produced by Heisey in the next few years. As near as we can ascertain, Sport was first produced circa 1928 and was discontinued by 1933. If vases are not your thing, you will have to do without Sport in your collection. If you like polo and color in Heisey you will have only this polo player in your collection.

Found on:

4209 - 9" vase in crystal, moongleam, and flamingo

495 Polo Player is one of the series of silhouette etchings and thus highly desirable. It is found basically only on a barware set with a decanter or cocktail shaker and choice of 3 styles of cocktails and several sizes of sodas. It was designed by Carl Cobel who did so many of the silhouette etchings for Heisey. Polo Player is available only on crystal. Since publishing the etching book we have found more accurate dating for this etching. It was listed as new on 6/18/37 and was discontinued in 1942 - two years earlier than we had previously been able to document. This and many other etchings were casualties of World War II.

Found on:

1495 FERN torte & cheese & cracker
2401 sodas
3405 ALIBI, 4002 AQUA CALIENTE, 4091 KIMBERLY cocktails
4035 decanter
4225 COBEL 1 qt. cocktail shaker



4002

Please add to your list:

5011 YORKTOWN 10 oz. soda, double sham



1495 FERN

The last of the Polo etchings, #498 Modern Polo Player, really was not last, except numerically. It too was produced from 1937 to 1942. (note change in discontinue date) Modern Polo Player is just that - a modern, stylistic rendition of a polo player & horse. It too is available only on crystal.

Found on:

4054 CORONATION barware
4091 KIMBERLY cocktail
1495 FERN torte & cheese & cracker

Please add to your list:

4054 CORONATION 12 oz. Slim Jim



4054 Soda

498 MODERN POLO PLAYER
Silhouette Etching



4091 Kimberly Cocktail

495 POLO PLAYER
Silhouette Etching



1 SPORT
Plate Etching

CLUB NOTES

GATEWAY HEISEY CLUB OF PITTSBURGH, PA.

June seventh the thunder clapped and the rains
came down:
As the Gateway Heiseyer's made their way across
town:
To Chins Polynesian Gardens for culinary de-
light
With a taste of wine and chatter to mellow the
night.
Next to Joe and Laverne Lokay's for the meet-
ing site:
Carlene presided-no new business was brought
to light.
Joe presented his Gibson Girls with their bus-
tles tight.
Showed us cartoons, plates, pictures, informed
us right.
Of Charles Gibson's talent over which men did
fight.
The Heisey for Show and Tell was a glorious
sight.
Suddenly a thunderclap adjourned the meeting.
Winds blew: the rains came down as homeward we
were fleeting.
Remember August second, the picnic meeting,
And so Darlene Sanders will be graciously
treating.

- Phyllis Freier

* * * * *

LONG ISLAND HCC

Since March we have been back from Flori-
da and meeting with our favorite Heisey Stu-
dy Club. LIHCC continues to carry on beauti-
fully and constantly develops new leadership.
Several members, including our club reporter
were ill much of the winter (must be that
northern winter) which accounts for the ab-
sence of news from our part of New York.

Regular meetings were held each month
as the weather cooperated and the winter was
mild with little snow. Educational programs
were held and a club project undertaken to
earn funds to be donated to our HCA Museum
in Newark.

Buttons designed by our club artist,
Maureen Kovacs, were sold at convention and,
after paying for the badges, the profits and
the remainder of the badges were donated to
the Museum. A special thanks to Dave Curley,
an HCA member from Rochester, for his assist-
ance in purchase of the buttons.

As of now we have a lively second Heisey
study club on Long Island. Several members
were found as a result of showing the "Heisey
Glass Story" in October of 1978. You will
hear more from this newly chartered club from
its own reporter.

L. I. was well represented at the all-
Heisey show in Alexandria, Va. in March and
also at the National Convention in June.

(cont. next column)

* Maureen Kovacs of our club designed the conven-
tion program cover and the beautiful posters at
the Heisey Glass Display as she has for the last
three years.

* Our club continues to have delicious food at
all meetings and are looking forward to our two
day meeting at Colangelos' home in the Poconos.

- Ruth Perloff

* * * * *

LETTERS, WE GET LETTERS...

* Well, we've attended our first Heisey Convention
and not one unpleasant memory do we have. The ter-
rific amount of planning, organization, and just
plain elbow grease was obvious if one took the time
to look around and think about it a minute. We
thank everyone who was gracious enough to share
their own pieces of Heisey for all of us to appreci-
ate within the displays.

* We've been members of HCA for less than one year
so the total amount of Heisey was rather staggering
to us, and only made us more determined than ever to
see, appreciate (and own) a larger collection than
we now have. One turn around the "Square" Saturday
morning helped increase our share (as it did many
others if the number of shopping bags being carried
back to the Sheraton was any indication.)

* Again we say "well done" for the Convention and
thanks for the very cordial atmosphere surrounding
all the proceedings.

- Arlene & Terry, Cranston, MI

* * * * *

* What an Experience! Breathtaking! might de-
scribe it, of Fabulous or just plain beautiful,
of course, I'm trying to describe my first steps
into the Heisey Museum in Newark.

* I could immediately appreciate all the work &
effort that had gone into making the Museum the
magnificent place it is.

* It is truly a beautiful tribute to a collect-
able that does not let you down, the more you see
of Heisey Glass the more you are impressed with
the quality and rare workmanship that went into
making it the outstanding product it is.

* Everyone connected with the HCA Convention was
most gracious and hospitable (Lets not forget a-
bout those delicious cookies). They all helped
to make this a memorable vacation and productive
shopping spree for me and my family.

- Babs Kent, N. Y.

* * * * *

* Just a note to say how much we enjoyed seeing
the Heisey Glass Museum-it was so interesting to
see the many different colours and designs. We
so appreciated the gifts you gave us. The horses
and bell look perfect in our lounge.

* We have a very clear photograph of us sampl-
ing the delicious punch you served us. Quite the
best I have ever tasted!

* Our only regret is that we had not allowed our-
selves more time in your Newark. We intend to re-
turn one day with the children so we can stay
longer.

* Looking forward to the day we can visit your
collection again.

-F. & D. Payne, Newark-on-Trent, England

REPORTS & DONATIONS FROM CLUBS..

The following were given or announced during the call of the clubs at the annual meeting on June 22. HCA thanks each and every one of you for your support. Many of the area clubs help staff the Museum all year round.

CHARTER

- 1 Newark HCC - Preparing "Heisey by Imperial" booklet. *
- 2 Reynoldsburg HCC - donated miniature alexandrite candlesticks in memory of Marcella Bethel. *
- 4 Central Illinois HCC - \$100 and an original letter and brochure from the Newark Chamber of Commerce dated 1927 concerning Wilson Heisey's campaign for National Director. *
- 5 Bay State HC - #4045 12" ball vase with 469 Mermaids etch and pair of sahara #140 candlesticks. *
- 6 Long Island HCC - Badges designed by Maureen Kovacs. All profits to Museum. *
- 9 Land of Heisey Society - \$500 cash. *
- 10 Gateway Heisey CC - Preparing a perpetual calendar. *
- 13 Heisey Club of California - \$1000 for acquisitions. *
- 14 Northern Illinois -Baked cookies for Hospitality lounge. Helped staff lounge. *
- 15 HCC of Michigan - Donated glass for March Auction - \$360 value. *
- 19 HC of Rochester Area - 3381 Creole, sahara bowl-oyster cocktail & sherbet. *
- 20 Buckeye HCC - Volunteered to pack glass again for March auction. *
- 21 Diamond H HC - Purchased settee for Museum upstairs. *
- 23 Heisey Collectors of Columbus - selling Diamond H Badges. *
- 24 HC of West Massachusetts - 3411 Monte Cristo cordial with 899 Manhattan cutting. *
- 26 Southern Illinois - \$200 to purchase a copy of the movie and #500 Octagon variety tray in dawn. *
- 27 Land of Legend HCC - #1401 Flamingo Lion's Head flat bowl and 133 double Swan candlesticks in flamingo. *
- 28 Western Reserve - #500 Octagon creamer & sugar in sahara in memory of Betty Eglet. Baked cookies for lounge. *
- 29 Heiseyland Variant Society - \$60.00 for acquisitions. Club now defunct. *
- National Capital HCC - \$500 for acquisitions and a pair or #141 sahara U shaped candlesticks purchased at all Heisey Glass Show. Helped staff lounge. *
- 32 Dairyland Heisey Club, Wisconsin - Baked cookies and helped staff the lounge. *

LIZ'S ANNUAL CONVENTION POEM..

Welcome to our Ninth Convention!
To have a good time is our intention.
To greet old friends from far and near
Is such a pleasure every year.

Primaries are over; the die is cast.
Will Reagan take over? Will Carter last?
Will elephants trumpet or donkeys bray?
Until November, who can say?

With Heisey the choice is greater you know.
There's Ridgeleigh, Plantation, Queen
Ann, Fandango
Empress, and Ipswich, and Winged Scroll too
To mention but a very few.

And colors range from Cobalt Blue
To Crystal, Sahara, and Hawthorne too;
Tangerine, Moongleam, lovely Limelight,
Flamingo and beautiful Alexandrite.

Elect your collectible, come and have fun
At the Victory party-everyone's won!
Eat, drink, and be merry. Tomorrow we buy
And buy and buy and buy and buy!

- Liz King



These are the original Heisey names for these cuttings.

NANCY JONES
 926 DOUGLASS DRIVE
 MCLEAN, VIRGINIA 22101
 (703) 356-0206

H = Marked P & I Extra

- 4224 IVY VASE, tangerine.....\$200.00
- 4075 Finger bowl, alexandrite..... 59.00
- 4054 CORONATION, experimental spiral
optic old fashioned, Dawn..... 145.00
- 3389 DUQUESNE 3 oz. cocktail, tan-
gerine WO (3).....ea.. 165.00
- 3389 DUQUESNE 8 oz. soda, tangerine.. 135.00
- 419 SUSSEX finger bowl, cobalt H.... 80.00
- 3404 SPANISH stem, 5½ oz. Saucer
Champagne, cobalt (2).....ea. 86.00
- 3404 SPANISH stem, 5½ oz. Saucer
Champagne with #797 cut H..... 40.00
- 3404 SPANISH stem, #865 Florentine
cut; cocktail, 2½ oz. wine,
oyster cocktail, 1 each....set 250.00
- 3481 GLENFORD 8½ oz. soda, Moongleam
foot (8).....ea. 12.00
- 1252 TWIST 3 oz. oyster cocktail,
marigold (4) H.....ea. 25.00
- 1170 PLEAT & PANEL 3 oz. oil
flamingo..... 45.00
- 310 RING BAND nappy, ivory H..... 46.00
- 1295 BEAD SWAG nappy, custard,
souvenir..... 52.00
- 1220 PUNTY BAND crimped nappy, Ruby H 58.00
- 1295 BEAD SWAG 8" Berry Bowl, Ruby
souvenir..... 60.00
- 1295 BEAD SWAG ½ gal. tankard & 2
tumblers, Ruby, souvenir..... 200.00

ALSO: #507 Orchid Etch, 85 pieces; Heisey
 Ruby Stained, 29 pieces. SASE for one
 or both lists.

WANTED: Locket on Chain and Touraine tooth-
 pick holders or will buy collections.



Bob & Fran's
ANTIQUES
2007 Broadway
VANCOUVER, WASHINGTON 98663

We Specialize in
Glass — China
Silver Flatware
Collectibles — Furniture

**WE PAY CASH FOR ONE PIECE, OR A
 COMPLETE SET OR COLLECTION.**

We invite you to come in and browse
MONDAY—SATURDAY—10 a.m. to 5 p.m.
2007 Broadway—(206) 693-7972
— We Like to Buy Old Things —

* * * * *

**ERIE'S SECOND ANNUAL
 GLASS SHOW AND SALE**

Featuring
 Cambridge, Duncan & Miller, Heisey
 and including
 Glass of All Periods

AUGUST 23 & 24, 1980

* SAT. 1 P.M. - 9 P.M. - SUN. NOON - 6 P.M.

HILTON HOTEL ERIE, PA

10th & State Streets
 * I-90 Exit 6 6 Miles North on Peach Street

SPECIAL GUEST:
 * Heisey Collectors of America Representative

* Admission 1.75 25¢ Discount with this ad
 Children under 12-Free Door Prize Each Day

* Promotion by: Hank Pugliese (814) 456-7131
 2947 Zimmerman Rd.
 * Erie, PA

VARNER'S MATCHING SERVICE
 1439 N. E. 13TH AVENUE
 ROCHESTER, MINNESOTA 55901
 TELEPHONE 507-289-2938

SAHARA:

1401	11" D. F. Floral bowl and pair of 134 2 lite candles.....	3 pcs.....	\$162.50
1417	ARCH tumbler.....	6 ea.....	25.00
1404	OLD SANDWICH 12" oval footed floral bowl (H).....	1 ea.....	75.00
1401	EMPRESS D. F. Creamer with LAFAYETTE etch (H).....	1 ea.....	27.50
1401	EMPRESS 12" round plates with 448 OLD COLONY etch (H)....	6 ea.....	35.00
1401	EMPRESS 8" square plates with 449 POMPEII etch (H).....	4 ea.....	16.00
1401	EMPRESS 8" square plate with 452 AMBASSADOR etch (H).....	1 ea.....	16.00

MOONGLEAM:

1401	11" D. F. Floral bowl and pair or 134 2 lite candles.....	3 pcs.....	185.00
------	---	------------	--------

AMBER:

4049	OLD FITZ 4 oz. hot whiskey (H).....	7 ea.....	65.00
------	-------------------------------------	-----------	-------

COBALT:

1404	OLD SANDWICH individual ash tray (H).....	8 ea.....	30.00
------	---	-----------	-------

HAWTHORNE:

3366	5 oz. Champagne (H).....	9 ea.....	22.50
------	--------------------------	-----------	-------

ANIMALS:

	3 piece FISH console set (Fish bowl and pr. Fish candles).....	3 pcs.....	650.00
	LIONHEAD bowl 11" Flamingo (Slight roughness on one foot).....		435.00
	SPARROW.....	2 ea.....	70.00

ETCHINGS:

SPRINGTIME: #457 (See HCA News, January, 1980)

3333	OLD GLORY 9 oz. Goblet (H).....	1 ea.....	30.00
3333	OLD GLORY Champagne (H).....	5 ea.....	25.00
3404	SPANISH Champagne.....	1 ea.....	30.00
3404	SPANISH Oyster cocktail.....	4 ea.....	20.00
1401	EMPRESS individual sugar.....	1 ea.....	30.00

MINUET:

1401	EMPRESS 11" floral bowl and pr of 134 2 lite candles.....	3 pcs.....	175.00
5010	SYMPHONY short stem Goblets.....	2 ea.....	25.00
5010	SYMPHONY tall stem Goblets.....	2 ea.....	25.00
1511	TOUJOURS 1 1/2" relish.....	1 ea.....	32.50

CUTTINGS:

3408	JAMESTOWN 9 oz. Goblet with SHEFFIELD cut #985 (H).....	4 ea.....	25.00
3408	JAMESTOWN sherbets with SHEFFIELD cut #985 (H).....	8 ea.....	17.50
3408	JAMESTOWN 2 oz. wines with SHEFFIELD cut #985 (H).....	9 ea.....	30.00
1185	YEOMAN 8" plates with SHEFFIELD cut #985 (H).....	12 ea.....	15.00
5024	OXFORD 11 oz. Goblet with MARYLAND cut #964.....	2 ea.....	25.00
3408	JAMESTOWN 9 oz. Goblet with BARCELONA cut #941 (H).....	3 ea.....	25.00
1540	LARIAT 12 oz. Ice tea with MOONGLO cut #980.....	3 ea.....	22.50

CRYSTAL:

397	COLONIAL CUPPED SCALLOP (See HCA News, December, 1979)		
	Jug with very good gold trim.....	1 ea.....	110.00
	Tumblers with very worn gold.....	2 ea.....	22.50
	Candy Tray 5" x 8".....	1 ea.....	30.00
470	INTERCEPTED FLUTE 10" bowl, bottom ground with star cut (H)	1 ea.....	30.00
1219	Handled & footed punch cups (H).....	8 ea.....	25.00
1404	CRYSTOLITE (?) 3 oz. Oil bottle with stopper.....	1 ea.....	27.50
1469	RIDGELEIGH Claret wines.....	4 ea.....	20.00
1469	RIDGELEIGH Champagne (H).....	1 ea.....	17.50
1469	RIDGELEIGH 3 oz. Oil bottle with stopper.....	1 ea.....	37.50
1506	WHIRLPOOL custard cup (H).....	18 ea.....	7.50
1506	WHIRLPOOL individual sugar, cream and tray (H).....	3 pcs.....	42.50
1540	LARIAT 6 oz. oil bottle with stopper.....	1 ea.....	45.00
1540	LARIAT covered bonbon.....	1 ea.....	37.50

Packing and UPS charges are additional
 We also match Haviland China--send list of wants (SASE please)

CAT'S MEOW
 P.O. BOX 27001, DIMOND STATION
 OAKLAND, CA. 94602
 PH. 415-531-5197

- 10 Floral block, Flamingo.....\$25.00
- 33 Toy candlesticks, pr. (M)..... 65.00
- 50 CABOCHON sign..... 245.00
- 300 PEERLESS 1 oz cordials (M) (5) ea. 25.00
- 411 TUDOR hotel sugar, hawthorne (M).. 45.00
- 1189 YEOMAN ind sugar/cov, flamingo,
 rare, (M) (2)..... 40.00
- 1473 BUTTRESS medium centerpiece (M)... 25.00
- 1503 CRYSTOLITE cologne, drip stopper. 50.00
- 1503 CRYSTOLITE 2 hand. preserve/cov(M) 25.00
- 1506 WHIRLPOOL 3½ oz. cocktails (M)(2) 15.00

Prices each, P & I extra. Please call after 5 pm. PDT.

CLASSIFIED:

WANTED: Eager to obtain 11" or 13" Shell Salad Bowl-1503 CRYSTOLITE. Call collect before 8 am or after 6 pm EDT. Area code 1-617-782-5886.

WANTED: Buying Depression Glass, Heisey, Cambridge, Fostoria, Akro Agate, glass figurals & unusual glass "cuties". NADINE PANKOW, 207 S. Oakwood, Willow Springs, IL 60480. Phone 312-839-5231.

FOR SALE: HEISEY 1401 Empress Moongleam punch bowl and extras such as punch cups, 6 inch covered candy dish, ice tub, pair of 135 candlesticks and others. Package deal, cash and carry. Write for details and price or make offer. JERRY BAKER P. O. Box 13081, St. Petersburg, FL. 33733. 1-813-898-0716.

FOR SALE: Heisey Hawthorne diamond optic: 8 dinner plates 10½", 9 dessert plates 8", 1 saucer 6". Flamingo meat platter 12x9½. H. GOETZ, 18 Hubbard Drive, White Plains, N.Y. 10606. 914-949-2068.

**THIRD ANNUAL
 All Glass Show**

**Sheraton — Sturbridge Inn
 Rte. 20 — Sturbridge, Mass.**

Sept. 27, 1980 Sept. 28, 1980
 Sat. — 10:30 AM - 6 PM Sun. — 9 AM - 4 PM

All Glass of All Periods

SPONSOR
 BAY STATE HEISEY COLLECTORS CLUB
 DONATION \$1.75 — with card \$1.50
 Benefit — Heisey Glass Museum

ROBERT H. DONOVAN PH 617-779-5008
 * P. O. BOX 321 AFTER 5 PM
 * BOLTON, MA 01740 P & I EXTRA SASE

- * PUNCH CUPS:
- * 1205 FANCY LOOP, Crystal & gold.....\$ 14.50
- * 1295 BEAD SWAG (4).....ea. 9.00
- * 1255 PANEL & SUNBURST* (7).....ea. 12.00
- * 300 PEERLESS* (4).....ea. 6.00
- * 300½ Colonial* (2).....ea. 5.00
- * 1425 VICTORIAN (5).....ea. 6.00
- * 1506 WHIRLPOOL* (21).....ea. 5.00
- * 150 BANDED FLUTE* (2).....ea. 8.00
- * 341 PURITAN.....ea. 6.00

- * PUNCH SETS:
- 433 GREEK KEY*..... 295.00
- * 1567 PLANTATION Dr. Johnson*..... 400.00
- 357 PRISON STRIPE*..... 395.00

- * SPECIAL PIECES:
- 429 COLONIAL PLAIN PANEL Punch base*... 24.50
- * 436 Carnation vase* 6"B. 13"H..... 98.50
- * 1255 PINEAPPLE & FAN salt & pepper..... 27.50
- 343 SUNBURST 10" nappy scallop*..... 29.50
- * 1506 PROVINCIAL tumblers, limelight(2)ea 30.00
- * 1506 PROV.12 oz ftd soda,limelight (8)ea 30.00
- 1506 PROV 5 oz. ftd soda,limelight(2) ea 32.50
- * 373 COLONIAL 1 oz cordial* (2).....ea 12.00
- * 1519 WAVERLY Orchid etch console set.... 59.50
- * 393 NARROW FLUTE ind. almond, cry & silver
 (8)..... 98.50

- * GOBLETS:
- * 3366 TROJAN w/Trojan etch d/o flamingo(2) 32.00
- * 3390 CARCASSONE sahara, 448 etch (6)..... 15.00
- * 3350 WABASH Frontenac etch (3).....ea 10.00
- * 1405 IPSWICH (4).....ea 20.00
- * 3355 FAIRACRE d/o (4) moongl & crys....ea 20.00
- 1425 VICTORIAN ftd. (2).....pr 15.00
- * 3411 MONTE CRISTO Olympiad etch (2)....ea 17.50
- * 3314 GRANDEUR Sabrina pl. etch..... 15.00
- 3381 CREOLE alexandrite (8)..... 700.00
- * 1252 TWIST* Red flash? (2)..... 27.50
- * 3404 SPANISH unknown etch..... 38.50
- 5067 PLANTATION IVY etch (4).....ea 35.00
- * 3440 PORTSMOUTH d/o (2) Rosy Tint Rare ea 42.50
- * 5010 SYMPHONY Minuet etch..... 30.00
- 1567 PLANTATION flared (3).....ea 28.00
- * 3404 SPANISH cry stem, cobalt bowl(5)....ea 75.00

- * 1184 YEOMAN d/o flared bar moongleam(5)ea 12.00
- * 1295 BEAD SWAG tumbler opal dec. (2)...ea 47.50
- * 3389 DUQUESNE ftd soda tangerine (2)...ea 180.00
- 3389 DUQUESNE sherbet tangerine (2)...ea 180.00
- * 1401 EMPRESS oyster cocktail (7).....ea. 8.00
- * 3381 CREOLE wine alexandrite (8)..... 700.00
- 3381 CREOLE cocktail alexandrite (8).... 625.00
- * 3408 JAMESTOWN w/BARCELONA cut 1 oz.
 cordial..... 36.00

* Many items in Twist, Plantation, Animals & Ipswich. Wanted Animals priced for resale.



* FOR SALE - #5066 HORSEHEAD Cocktails.
 * Write for price. AL MILLER, 1728 Grandview
 * Ave. Shelbyville, KY 40065.

SECOND ANNUAL Glass BASH SHOW AND SALE

AUG. 22-23-24 * STRONGSVILLE, OHIO

Located between Akron & Cleveland
HOLIDAY INN * I-71 & Rt 82
exit 10 South off Turnpike

SHOW HOURS:

FRIDAY PREVIEW - 7 p.m. to 10 p.m.
Preview Admission - \$3.50

SAT. & SUN. - 11 a.m. to 5 p.m.
Admission - \$2.50
(Sat. or Sun. Adm. \$2 w/ad)

NOTE: Seminars begin 10 a.m. Sat. & Sun.

MEET THE GLASS REVIEW STAFF:

- * Barbara Shaeffer - CA
Publisher/Editor
- * William Heacock - OH
Associate Editor
- * Gwen Shumpert - MS
Feature Editor
- * Contributing Editors:
- * Gail Krause - PA
- * Clarence Vogel - OH
- * Leonard Padgett - MD
- * Dr. James Measell - MI
- * Fred Bickenheuser - OH
- * Feature Writers:
- * Phyllis Smith - OH
- * Bettye Waher - FL
- * Roserita Ziegler - CT
- * Audrey Humphrey - OH
- * Steve Jennings - WV
- * Grace Allison - OH

* Selected glass dealers offering a variety of glass treasures for sale - Antique to Contemporary: pressed, cut, depression, Art, Heisey, Cambridge, Fostoria, Carnival, Duncan, Fenton, Boyd, Summit, New Martinsville, Imperial, L.G. Wright, St. Clair, Morgantown, Degenhart, etc.

GUEST SPEAKERS:

- * William Heacock - "Fenton Art Glass - The First Fifty Years: 1905-1955"
- * Fred Bickenheuser - "Tiffin Glass - The Last Frontier of Colored Glass Collecting"
- * Roserita Ziegler - "Post 1950 Collectible Glass With An Investment Future"
- * Edna Barnes - "Degenhart Glass: 1947-1978"
- * Dr. James Measell - "There's More to Collecting Glass Than Just Collecting Glass"
- * Leonard Padgett - "Fakes and Trademarks"

DISPLAY: OPEN GLASS SALTS representing dozens of glass factories shown by Irene Bobrowicz, charter member of New England Society of Open Salts, Inc.

FREE GLASS IDENTIFICATION: Bring your glass "mysteries" for our staff of writers to help identify - limit 2 items - no appraisals

BANQUET SPEAKERS - AUGUST 23 - 7 p.m.

- * Dr. James Measell - Author of Greentown Glass
"There's More To Collecting Glass Than Just Collecting Glass"
- * Mr. Leonard Padgett - Author of Pairpoint Glass
"Glass Fakes And Trademarks"

ADVANCE RESERVATIONS NEEDED - \$15 PER PERSON

Press by GLASS REVIEW, the all glass magazine devoted to "Keeping Glass Collectors Informed." P.O. Box 2315, Costa Mesa, CA 92626 or call Barbara Shaeffer at (714) 642-7636.



The Strongsville Holiday Inn is conveniently located at Interstate 71 and Route 82. Only one minute South of Exit 10 and Ohio Turnpike (I-80).

Only 10 minutes from Cleveland Hopkins Airport. Free airport limousine service - Call Strongsville Holiday Inn.

*

Special rates for rooms at the Holiday Inn. Send for rate card from Glass Review, P.O. Box 2315, Costa Mesa, CA 92626.

- SPEAKERS SCHEDULE -

Note: Seminars begin 10 a.m. - one hour before show opens

SATURDAY

- 10 a.m. "Fenton Art Glass - The First Fifty Years: 1905-1955"
Mr. William Heacock
Associate Editor of GLASS REVIEW and author of 9 books on glassware.
- 2 p.m. "Degenhart's Crystal Art Glass Company: 1947-1978"
Mrs. Edna Barnes
Dealer and Collector of Degenhart Glass.

SUNDAY

- 10 a.m. "Post 1950 Collectible Glass With An Investment Future"
Mrs. Roserita Ziegler
Feature Writer for GLASS REVIEW
- 2 p.m. "Tiffin Glass - The Last Frontier of Colored Glass Collecting"
Mr. Fred Bickenheuser
Contributing Editor of GLASS REVIEW and author of a book on Tiffin Glass.

- Lectures will be held in the Stearns Room - Free with Glass Show Admission -

MOSTLY HEISEY
RHODA CURLEY
 16 Clayton Place
 Albany, New York 12209
 By Appointment (518)482-6272

LAST CHANCE ANTIQUES
 N. Federal Hwy., Dania, Fl. 33004
 (Between Miami & Ft. Lauderdale)
 Large HEISEY Inventory & other Glass
 Mail Orders (305)467-6356 (home)

GOLDSBERRY'S ANTIQUES
 KALAMAZOO, Michigan
 Shows Only -- Buy & Sell
 HEISEY A Speciality
 Phone: (616)381-3013

SCHWAN'S ANTIQUES
DICK & LEE SCHWAN
 208 OXFORD ROAD
 WILLIAMSBURG, VA. 23185
 (804)229-7873 Shows & Appt.

GREEN ACRES FARM
 Antiques, Crystal Glass & Collectibles
 2678 Hazelton Etna Road, S.W.
 (S.R. 310 N.) Pataskala, Oh. 43062
 Sat. & Sun. P.M. or Call (614)927-1882

BERT'S BUDGET SHOP
 General Line Antiques
 403 W. Main St., Newark, Oh. 43055
 Phone: (614)349-8045

THE WOODEN SHOE
 Antiques & Collectibles-Buy & Sell
 Glass, Furniture, Estates
 Jim & Sheri Vanes, By Appointment
 Herndon, Va. 22070 Phone: 435-9045

CURIOSITY NOOK
 "Where Friends Meet To Antique"
 3300 S. 8th. Ave. Westward Village
 Yuma, Ar. 85364 (602)726-6730 or 726-8070
 Barney & Jody Barnicle

CURIO CORNER
 Accent Antiques of Kensington
 3742 Howard Ave.
 Kensington, Md. 20795
 Phone: (301)933-3750

ANTIQUES BOUGHT
BOB SHULTZ SOLD
 206-208 E. Main St., Route 419
 Newmanstown, Pa. 17073
 15 Mi. West of Reading, Pa.
 Phone: (215)589-2819

OLDE LOVED THINGS
 ANTIQUES & COLLECTIBLES
 Daris 'ed' Lacroix - Donald Mousseau
 900 Ridgewood Avenue (Holly Hill)
 Daytona Beach, Fl. 32017
 HEISEY, CAMBRIDGE, Mail Order (904)252-7960

OFF-BROADWAY ANTIQUES
HEISEY GLASS & GENERAL ANTIQUES
 121 S. Prospect St., Granville, Oh. 43023
 Open 7 Days A Week 12-5 P.M.
 Shop (614)587-2083 Sam 587-0052

LYNNE & ART'S GLASS HOUSE, INC.
 'HEISEY OUR SPECIALTY'
 Miami Beach, Fl. 33154
 P.O. Box 54-6014
 (305)861-7700 (305)895-5666

HEISEY HEAVEN & other collectables
 Box 78 Rt. 1
 Mansfield, Il. 61854
 Ph: (217)489-4071
 Hours: 1-5 Daily

WICKFORD ANTIQUE ARCADE
RON & BEV WOOD Booths 6 & 7
 650 Ten Rod Rd., N. Kingstown, R.I. 02852
 Heisey, Primitives, Glass, Etc.
 Home Phone: (401)295-0823

DIAMOND H PLUS
 George & EILEEN SCHAMEL
 Rt. 3 Box 419 Boonsboro, Md. 21713
 Appointment or Mail Order
 Phone: (301)432-6285

HEIDI-HO ANTIQUES, INC.
 HEISEY and GENERAL ANTIQUES
 838 S. High St., Columbus, Oh. 43206
 Phone: (614)444-5774
 Hours: Wed.-Sat. 11-5, Sun. 1-5

THE CONNECTICUT YANKEE
 'HEISEY OUR SPECIALTY'
 707 S. Washington
 Route 2, Box 315
 Fredericksburg, tx. 78624

CHARLES & MILDRED FISHER
 Antiques & Collectibles, General Line
 HEISEY, DEGENHART, IMPERIAL
 991 Idlewilde, Newark, Oh. 43055
 Phone: (614)522-5398

EAGLES REST ANTIQUES
 CHINA HEISEY GLASSWARE
 Bought and Sold
 62 Field Point Rd., Heath, Oh. 43055
 By Chance or Phone: (614)522-2035

SUM OF LIFE
ELAINE & FRANK HUSTED
 P.O. Box 102
 Phoenixville, Pa. 19460
 Phone: (215)935-2962

THE "FINDERS" ANTIQUES
DAVID & SHIRLEY ROSE
 513 E. Main Street
 Newark, Oh. 43055
 Phone: (614)349-7934

MOUNDBUILDERS ANTIQUES
IRENE RAUCK
 1138 Moundview, Newark, Oh. 43055
 Phone: (614)344-6043
 Heisey & Animals General Antiques

HAPPY HAVEN ANTIQUES
MARY DUMKE
 14319 Rattlesnake Road
 Grass Valley, Ca. 95945
 Phone: (916)273-9450

CHARLES A. SHAW
 Glenwood Gardens - Rip Van Winkle
 Yonkers, N.Y. 10701 Ph: (914)476-5175
 American Glass
 Shows and Mail Order

THE SLEEPING FOX
EVELYN & JAMES JORDAN
 P.O. Box 583
 Lansdale, Pa. 19446
 Phone: (215)855-2480

GEORGE HOFFMAN ANTIQUES
G.W. HOFFMAN - J.H. DENNIS
 129 South 4th. Street
 Newark, Oh. 43055
 Phone: (614)345-8021

RAMBLING LANE ANTIQUES
KEITH & EVELYN HOOVER
 Featuring HEISEY and Other Fine Glass
 Rt. 4 Box 1005 Rineland, Wl. 54501
 Phone: (715)282-5019

ANN'S GIFTS & ANTIQUES
 105 W. Main St., Hebron, Oh. 43025
 Intersection Rt's 40 & 79
 Next Door to Daisy Queen
 Daily 11:30 A.M. to 5:30 P.M. Closed Thursday

RECOLLECTIONS
THERESA WERT
 Lahaska Antique Center
 Route 202 Lahaska, Pa.
 Phone: (215)794-8667

BOB & FRAN'S ANTIQUES
 CHINA - HEISEY - GLASSWARE
 SILVER FLATWARE
 2007 Broadway Vancouver, Wa. 98663
 Phone: (206)693-7972

8TH ANNUAL MINI-SHOW
AND FLEA MARKET

SEPTEMBER 13, 1980

(FORMERLY HELD IN NEWARK, OHIO ON THE HEISEY MUSEUM GROUNDS)
THIS YEAR AT A NEW LOCATION ! !

9-4 PM

75¢ ADMISSION

REYNOLDSBURG HIGH SCHOOL
6699 E. LIVINGSTON AVE.

(VERY CLOSE TO TWO EXITS OFF I70)

With ANNUAL SOUVENIR DINNER being held at STONEY CREEK COUNTRY CLUB
(Executive Caterers) on BRICE ROAD, REYNOLDSBURG, the MINI-SHOW will be held
nearby in Reynoldsburg for your convenience.

FOR DEALER SPACE,
OUTSIDE SPACES ONLY ARE LEFT

REYNOLDSBURG HCC
c/o SHIRLEY BAGFORD
1290 HILTON DRIVE
REYNOLDSBURG, OH 43068
(614) 866-4035



FIRST-CLASS MAIL

FIRST CLASS MAIL
U.S. POSTAGE
PAID
PERMIT 34
Reynoldsburg, Ohio 43068

MUSEUM HOURS ARE NOW open daily from 1-4 p.m. except Monday and holidays