

HEISEY *news*

OFFICIAL PUBLICATION HEISEY COLLECTORS OF AMERICA

© Heisey Collectors of America, Inc.
All Rights Reserved 1990

VOLUME XIX NO. 1

JANUARY, 1990 ISSN 0731-8014



TREASURER'S REPORT

At the December Board meeting on December 8, the Board of Director's approved for audit the following Treasurer's Report.

| | |
|-------------------------------------|-------------|
| CASH BALANCE AUGUST 31, 1989 | \$ 9,633.29 |
| TOTAL CASH RECEIVED | 42,476.67 |
| TOTAL CASH PAID OUT | 46,099.50 |
| BALANCE NOVEMBER 30, 1989 | 6,010.46 |
| BALANCE ON LOAN AT BANCOHIO | 19,000.00 |
| BALANCE IN ENDOWMENT FUND | 44,627.06 |
| BALANCE IN SPECIAL PROJECTS ACCOUNT | 107.47 |
| PROFIT FROM SOUVENIR DINNER | 4,234.96 |
| NUMBER OF BOB EVANS STOCK - SHARES | 7,054 |
| CURRENT VALUE OF BOB EVANS STOCK | 97,874.00 |

HEISEY NEWS

P.O. Box 4367, Newark, OH 43055

CLUB OFFICERS:

| | | |
|----------------|-----------------|----------------|
| President | - Bob Rarey | (614) 279-0390 |
| Vice President | - Dick Smith | (614) 366-5163 |
| Secretary | - Amy Jo Jones | (513) 426-8668 |
| Treasurer | - Betty Barnard | (614) 366-7002 |
| Curator | - Louise Ream | |

Editor: Louise Ream

P.O. Box 4367, Newark, Ohio 43055

PH: (614) 345-2932

Published in Newark, Ohio, Printed in Newark, Ohio.

\$15.00 per year - \$1.25 per copy

Back Issues - Each Volume (12 issues) year - \$9.00
Volume V, VIII, IX, X, XI, XII, XIII, XIV, XV, XVI, XVII

Heisey Collectors of America, Inc. is a non-profit corporation with tax exempt status. Owners and operators of National Heisey Glass Museum, 6th and Church Streets, Newark, Ohio.

Open daily 1-4 p.m. except holidays. Other hours by appointment. Members admitted free.

HEISEY NEWS

Heisey Collectors of America, Inc.

All Rights Reserved 1990 - ISSN 0731-8014

Published monthly, except twice in February, by Heisey Collectors of America, Inc., Newark, OH 43055. Second Class postage paid, Newark, Ohio 43055. Club membership (includes 13 issues of Heisey News and participation in all club activities) \$15.00 per year plus \$2.50 for each additional family member in same household who wishes a membership card. For Voting Membership add \$25.00 one time only fee.

POSTMASTER: Send address change to:
HCA, P.O. Box 4367, Newark, OH 43055

When requesting information, please enclose a self-addressed, stamped envelope (SASE).

ADVERTISING - Send all ads to: HCA - Advertising
P.O. Box 4367
Newark, Ohio 43055

DOUBLE SPACE ALL ADS

Rates:

CLASSIFIED: 15¢ per word. \$1.50 minimum.

ABBREVIATIONS AND INITIALS COUNT AS WORDS

DEALER DIRECTORY: \$25 per year.

| Display: | Members: | Non-Members: |
|---------------------------|----------|--------------|
| 1/8 page (9 items) | \$20.00 | \$ 30.00 |
| 1/4 page (20 items) | 30.00 | 45.00 |
| 1/2 page (20 items) Hor. | 45.00 | 67.00 |
| 1/2 page (50 items) Vert. | 60.00 | 90.00 |
| 1 page (50 items) | 75.00 | 112.50 |

Personal ads limited to 1/8 space.

ALL ADS MUST BE PREPAID. Ad copy must be received by the 5th of the month preceding the publication date-i.e. April 5th for May issue. Ads containing reproductions will not knowingly be accepted unless clearly stated (i.e. Heisey by Imperial, etc.). HEISEY NEWS assumes no responsibility for false advertising or misleading information. In the event of typographical error, the incorrect portion of the ad will be run in the following issue, but HEISEY NEWS assumes no further liability.

The opinions expressed in articles in HEISEY NEWS are those of the authors and not necessarily those of the organization. The Editorial Staff reserves the right to edit or refuse any material submitted for publication. When requesting information, please enclose a self-addressed stamped envelope (SASE).

1489 PURITAN.

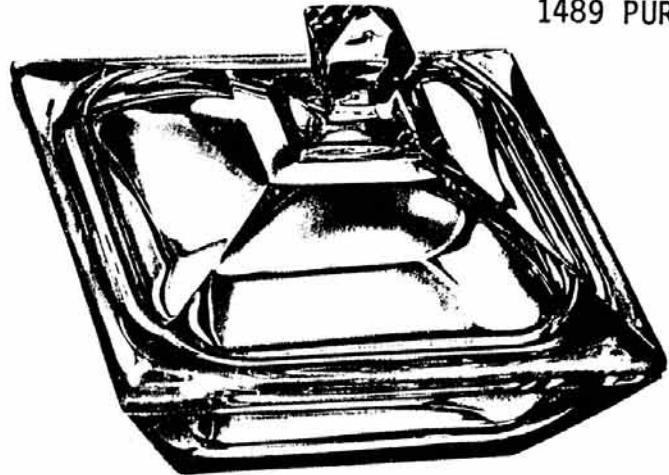

Above is pictured a new design from A. H. Heisey & Co. - a seven inch square candy box in heavy Crvstal, with a domed cover and square knob, done in the same style as the much liked square centerpieces, cigarette box, and ash trays. The candy box may be retailed for \$6.00. (This was made in two sizes.

ABOUT THE COVER

1947 - HEISEY EMPLOYEES

left to right: William Fairall,
Clarence Heisey, George Smeltz
and Paul Fairall.

NOTES FROM YOUR PRESIDENT

A new year and a new decade. My report to you this month will cover actions taken by the Board of Directors at their meeting on December 8. The Treasurer's report and Curator's report will be covered elsewhere in this issue.

Neila Bredehoff's Archivist report stated that since her last report, much had been accomplished. She stated that 137 catalogues and price lists had been examined, processed and listed in the computer, wrapped in acid-free paper, placed in acid-free boxes, and stored. This work is not complete as there are several more catalogues to process. The Board voted to purchase a blanket insurance policy for \$50,000 coverage until an accurate inventory is available. The coverage is for the paper and other items acquired by the Archives and Research Committee.

Christos Maskaleris, Chairman of the Inventory Committee, reported that the committee would begin a non-glass inventory update after the start of the New Year.

The 1990 Souvenir "Oscar" will be made by Fenton in their Rosaline color. They will be available sometime in February.

A by-laws change, submitted by Dick Smith, to the Executive Committee, and recommended to the Board, briefly states that "Executive Committee members will also be members of the Board of Directors". Charlie Wade had suggested such a change after he retired from the Board. He felt an Executive Committee member could not adequately serve the Board and not be a member of the Board. Passed by the Board, this by-law change will be presented for a vote of the members at the Annual Meeting in June.

Bob Ryan, Co-Chairman of the Benefit Auction, reported that as of December 8, 620 lots were catalogued and that several boxes were on hand to be processed. Many outstanding pieces are included in the sale, rare beautiful cuttings and a good selection of colored items.

It was the decision of the Board that since the Museum Benefit Auction was a profit making event for the benefit of the museum, that the use of credit cards was taking from that profit and actually penalizing those buyers who were paying cash. It was decided to charge a 5% buyers premium for credit card use. This buyers premium applies only to purchases at the Benefit Auction. Credit card sales will continue in the gift shop as always with no buyers premium.

After considerable discussion, the Board voted to again hold the 200 dinner in April, the date yet to be decided. HCA needs more participation by Study Clubs and individuals in this event. This was started as an event to payoff the Warehouse purchase. This year (1990) will nearly complete the payoff of the bank loan which was \$75,000 in the beginning.

As stated earlier, Charlie Wade felt that members of the Executive Committee should be Board members. At the December 4 Executive Committee Meeting, he had submitted his resignation. Sam Schnaidt was elected to fill the vacancy, as provided in the Constitution of Heisey Collectors of America, Inc.

Dates to remember: March 9 and 10, All-Heisey Benefit Auction; March 11, Starlight School Show
A happy and prosperous new year to all!

Bob Ryan

FROM THE DESK OF THE EDITOR

We hope you all had a wonderful Christmas or Hanukkah season. We wish all of you could have seen our lovely museum with its beautiful decorations. Also, our dinner at the Trout Club was very nice and everyone had a good time. It was followed by a little party at the museum to give people the opportunity to see and enjoy the decorations and lights.

Since the siding on the outside of the building has been restored and beautifully repainted, it is a breathtaking sight. Candles in the windows and a big wreath on the door are even lovelier with the floodlights which we use every Christmas to highlight the museum, make it all the more attractive.

We have been very busy in the museum both with our regular duties and with people coming to buy all the new goodies. If you haven't come to buy or haven't ordered the Ruby sparrow, cygnet or bunnies please hurry as they are going fast. We have just learned that the Ruby colts which you bought for \$60 less 10% have been selling for \$125 to \$150 a set. They were a limited edition as are the three new items. Leonard is also busy sending out orders to arrive before Christmas.

Bob Ryan and his committee are still working on the auction glass. They have listed 615 items so far and they still have a lot more to do. Also, glass is still coming in and probably will do so until January 1. (It is December 15 now when this newsletter goes to press).

Bob Ryan didn't have time to write anything for this newsletter as his daughter has been ill but he will have an article in the February issue, the same month you will be receiving the list. He says there are many nice items this time, including many favor vases, candlesticks, candelabra, several baskets, old patterns, Zircon cane, and hundreds of other goodies.

Amy Jo Jones, Convention Co-Chairman, is ill and couldn't get a column written about the convention. The theme will be "Heisey Salutes the Nineties". You can decide which "nineties" you want, either 1890's or 1990's. This seems to be a theme that would be easy to work with.

There will be many changes at the convention this year but Amy Jo can tell you about them later. The registration information will appear in the May and June issues as usual.

The prices of rooms at The Best Western Inn are on page 23 of this issue. It fills up fast so get your reservations in soon. Other motels will be listed next month.

It is time once again to order the Oscar, 1990 version, which is Fenton's Rosaline.

According to Frank Fenton, "Rosaline is a heat-sensitive glass which contains gold to develop the pink color". We think this should be a popular color so order early. They will be sent as soon as we receive them, which should be in early February. (New members might not know what an "Oscar" is. It is a figurine also called Sparkie, Spark Plug, and Plug Horse. It really is a sort of a "Caricature", and many members consider it to be the mascot of H.C.A.) This has been our Convention Souvenir since 1977.

Louis Brown



diamonds
are
forever
by
Janet
Caswell

Happy New Year to you and you and you! "1990", a new decade, a new year, a new beginning. Perhaps this would be a good time to think about the past year and the events that have transpired, good or bad. Let's not dwell on the unfortunate, let's be pleased about the pleasant things. Just think how the people must have felt when the Berlin Wall came down; to be with family and friends again, and to be able to travel from east to west with no problem. How lucky we all are here in the United States.

Perhaps we could do just one kind deed each day for another person.

Perhaps we could write to someone we haven't seen or heard from for a while.

Perhaps we could make a long overdue phone call to rekindle an old friendship.

Perhaps we could visit a shut-in, play cards with them or write a letter for them or do an errand. Remember, when you put a smile on another face yours lights up with happiness.

Also, remember to do something for yourself each day - you're special too! Promise yourself at least one Flea Market each week and bring home the Heisey!

Bringing home the Heisey is just what Yours Truly did last week. I went to a few of my "old haunts" to no avail, narry a bit. What I saw was Colonial, and because there was a diamond H on the bottom, the dealers thought the pieces commanded a high price. For example: a Colonial berry set with one large nappy and three small ones was priced at \$75. A bit much! At another Antique Center in the "Witch City" (Salem, MA) I didn't see even one piece of Heisey. At the last place I visited for the day, in the last aisle, next to the last booth on the top riser, was a "pair" of toy candlesticks. On taking them down I discovered, to my dismay, they were indeed not a pair. I had a difficult time explaining to the dealer just why I only wanted to buy one, but she finally agreed that they were not alike. She split the pair and the #31 Tom Thumb candlestick became mine. Oh joy! For less than a "Wendys" meal. What else did I get - let me see: Greek Key #433 one handled jelly; #331 Colonial Panel individual salt (square) with spoon; #358 ash tray in Flamingo; #1404 Old Sandwich Sahara tumbler - two of these.

"The Steadfast Colleague" called the other evening very excited and a little ruffled; after talking for awhile, he finally couldn't hide his joy any longer and spilled out his finds: #451 Cross Lined Flute handled jelly; #300 water bottle; Caramel Slag sparky (Imperial); a Verlys Zircon Pine Cone bowl with the original label.

Now, "The Cardinal" (MA) of the Bay State decid-

ed to fly to another state and, when he finally decided it was time to come back to his nest, he brought with him the following two treasures: two (2) Arch tumblers, both Crystal but one of these valuable pieces had feet. Very, very nice find. His set of Arch tumblers is almost complete.

The "Keystone Cops" (PA) have been out roaming the fleas with their "billy-clubs". I wonder if anyone fears them? No, not the Keystones, they're harmless. Nevertheless, home they came with four (4) #2323 Navy glasses, 7½ oz, Old Fashions. These were for Mr. Keystone as he is the one who collects Navy. I guess he is trying to corner the market on Navy glasses. With that billy-club at his side who has a chance.

The "Canadian Goose" came up with a #1205 Rain-drop floral bowl in Moongleam. What a catch!

Now there is this perfectly dedicated person that is "Hooked on Heisey" who just couldn't wait to report his new acquisition of the #5003 Flower Urn and a #1503 Crystalite footed tumbler.

From the Land of Lincoln the "Heisey Cohorts" wrote me a long letter just to tell me about the fact that Heisey hunting has been excellent and they have the covered sugar, covered butter and creamer in #1295 Beaded Swag - in Opal with no decoration except Gold on the outer edge of the butter bottom. Also, in Beaded Swag, a Ruby flashed toothpick and a covered sugar, creamer and spooner with a Ruby stain band with engraving, also Gold beads.

The "Friendly Fox" came out of her den long enough to discover the #7000 Sunflower butter dish with cover. This must be the month for butter dishes to come out of the woodwork.

"My First Heisey Friends" have a pair of Trident #134 candlesticks with Heisey Rose Etch and also a pair of #134 Trident candlesticks with Orchid Etch, plus a #170 Cut Block (square in Diamond Point) cruet with original stopper.

From (Conn) The "Two Guys" report #5012 Crystal vase with #507 Orchid Etch plus a Crystal mustard spoon.

The "Bay State" (MA) there are rumors that The "Farmer" reaped his harvest of a #1205 Fancy Loop 8" oval relish and a pair of #114 Pluto Flamingo candlesticks.

"Empire State Gal" says her French dressing bottle with Orchid Etch is beautiful.

"Vel Now" Ole and Minnie want to report vot they got; seven (7) champagnes in Ridgeleigh and also in Ridgeleigh (8) goblets. Perhaps they will have a party and use them all, that would be fun.

"My Sharp Eyed Friend" has a #497 Rosalie Etch on the #1401 Empress dolphin footed jelly plus a #1255 Pineapple and Fan 13 oz Crystal molasses can.

The "Midnight Riders", again under the cover of night, filled their capes with a #305 Punt and Diamond Point water bottle, along with the #4166 Balda jug - cut. Uhhmmmm!

Again, from the Yachting Center, Happy New Year to you all.

Perhaps you could make my year happy by sending me so many letters with so many Heisey finds that I will be exceedingly happy. Thank you.

"Laughter translates into any language"
(McNaught syndicate)

Be Happy Hunting Heisey!!

HEISEY BY IMPERIAL - NO. 1591 STORYBOOK MUG

By Tom Felt

A few years ago during Convention, I was stumbling around the flea market on the square at an ungodly hour, wondering what I and everyone else was doing up so early. (Those of you who haven't been to Newark in June yet, don't know the peculiar ritual we engage in of greeting the dawn on Saturday morning when, after a busy week, we should all be snug in our beds instead.) As a collector of the storybook mugs, on one of my circuits I noted that a dealer had set out a set of four in colors which I already had, but that it was so early that they had misted over. I don't recall now how it is that I happened to pick one of them up but it was only then that I discovered that mist had nothing to do with the mugs' appearance and that, in fact, all four had frosted or satin finishes.

I was immediately excited because I knew from the Imperial book that some mugs in Crystal had been made with a satin finish in 1977 on an experimental basis, but I had never seen one for sale nor were any of the other three colors even listed. Needless to say, I snatched all four, once again aware that with so much glass having been sold out of the Hay Shed, there is never any point at which you can say that an Imperial collection is complete -- there's no telling how many variant or experimental pieces may turn up which aren't in the book.

The four mugs (two of which are pictured) were in Crystal, Ultra Blue, Fern Green, and Nut Brown and, quite frankly, are not among the most attractive storybook mugs ever manufactured, but were nevertheless a delightful addition to my collection. One of the first things I discovered, however, is that my Crystal mug was not necessarily one of the experimental few made in 1977, since the example on display in the Museum has a fine frosting reminiscent of Imperial's Cathay pieces, whereas all four of my mugs have a dull matte finish, similar to that used on the Slag mugs made from 1975-1977. Judging from the colors involved, around 1978, would be a good guess for the year of production, since the storybook mugs were issued in both Nut Brown and Ultra Blue that year; however Fern Green was never a production color for the mug, except as a special order in 1975, so they could date from anytime between 1975 and 1979.

The original storybook mug (called a "child's cup") was designed by Horace King and made in Crystal from 1947 - 1950. Imperial seems to have initially reissued the mug as a special order for E. Ward Russell in various carnival finishes and it was at his request that the plain panels were stippled. The first mugs made for him had ground bottoms, but all of the later ones have a collared base instead. By 1971, the mug had been added to Imperial's catalog and it remained popular for many years, later providing a steady source of income for the HCA gift shop -- indeed, it's still a popular sales item in versions made by both Fenton and Dalzell Viking, so that by now a "complete" collection includes more than 30 mugs (or more, if you also collect the various marks). What follows is a summary of the colors and finishes that I am aware of:

| | | | |
|----------|-----------------------------|--------------------------------|-----------------------------|
| Imperial | Blue carnival* ¹ | IG** | Possibly ca. 1970 (20 made) |
| | Helios carvinal* | IG EWR (1)** | Ca. 1970 (351 made) |
| | Aurora jewels (carnival) | IG | 1971 - 1972 |
| | Sunset ruby (carnival)* | IG EWR** | Before 1973 (390 made) |
| | Amber carnival* | IG** | Ca. 1973 - 1974 (320 made) |
| | Amber carnival* | IG EWR (1)** | Ca. 1973 - 1974 (484 made) |
| | Amber carnival* | IG EWR Nixon-Agnew | Ca. 1973 - 1974 (467 made) |
| | Fern Green* ² | IG | Ca. 1975 |
| | Fern Green* | IG H EWR 1895-Heisey- 1975 | 1975 (338 made) |
| | Fern Green, satin | IG | Unknown (possibly ca. 1978) |
| | Caramel slag, glossy | IG | 1975 - 1977 |
| | Caramel slag, satin | IG | 1975 - 1977 |
| | Ruby slag, glossy | IG | 1975 - 1977 |
| | Ruby slag, satin | IG | 1975 - 1977 |
| | Jade slag, glossy | IG | 1975 - 1977 |
| | Jade slag, satin | IG | 1975 - 1977 |
| | Ultra blue* | IG H EWR 1901-Imperial 1976 | 1976 |
| | Ultra blue | IG | 1978 - 1979 |
| | Ultra blue, satin | IG | Unknown (possibly ca. 1978) |
| | Crystal, satin ³ | IG | 1977 (experimental) |
| | Crystal | Various (IG,LIG,ALIG***) | 1978 - 1984 |
| | Crystal, matte satin | IG | Unknown (possibly ca. 1978) |
| | Milk glass | IG | 1978 - 1979 |
| | Nut Brown | IG | 1978 - 1979 |
| | Nut Brown, satin | IG | Unknown (possibly ca. 1978) |
| | Horizon blue carnival | Various (IG, LIG) | 1979 - 1981 |
| | Meadow green carnival | LIG | 1980 - 1982 |
| | Pink | ALIG | 1984 (200 made) |
| | Sunshine Yellow | ALIG | 1984 (100 made) |
| | Light blue | ALIG | 1984 (100 made) |
| Fenton | Copper Blue*** | HCA 87 | 1987 |
| | Ruby*** | HCA 88 | 1988 |
| | Teal, blue/green | HCA 89 | 1989 |

(continued on next page)

Dalzell Viking

Ruby***

Evergreen***

HCA 89

HCA 89

1989

1989

*Special order for E. Ward Russell

**Ground bottom

***Still available from the HCA gift shop

1. This may be the same as the Aurora jewels mugs made later for regular production and listed below.
2. Made for E. Ward Russell, but since the wrong bottom plate was used, they were sold in the Hayshed.
3. This is a fine satin finish, similar to that used on the Cathay line.

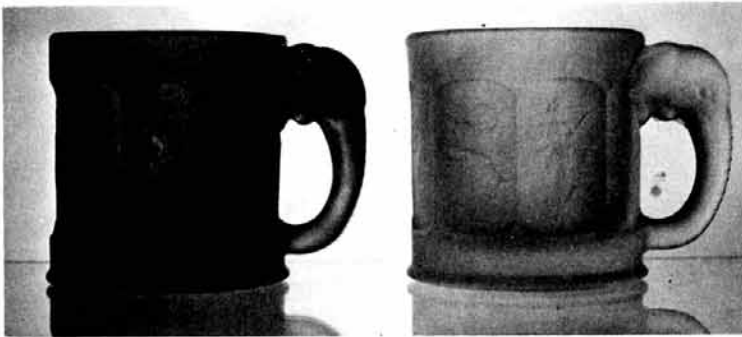

Frosted Storybook Mugs

HOW YOU CAN SUPPORT HCA AND THE NATIONAL HEISEY GLASS MUSEUM

YOU SHOULD CONTACT YOUR ATTORNEY CONCERNING THIS BUT THE FOLLOWING LANGUAGE IS SUGGESTED FOR USE:

You can support Heisey Collectors of America, Inc., owner of The National Heisey Glass Museum in Newark, Ohio, through any of the following means:

GIFTS IN YOUR LIFETIME

Gifts in cash, securities, or real or personal property (such as Heisey Glass) provide immediate support for general purposes. In addition, such gifts can be given for acquisition of Heisey Glass for the museum, Endowment Fund or any special project.

- Special event gift: To recognize a special occasion.
- Gift of thanks: To honor a volunteer or other person.
- Memorial Gift: To commemorate a special relative or friend.

WHEN THERE IS A WILL

By means of a simple codicil, a bequest to The Heisey Collectors of America, Inc., owners of The National Heisey Glass Museum may be added to an executed will. It is recommended that when making bequests or planned gifts that you consult an attorney who can advise you on the tax advantages of the gift. HCA is a Non-Profit Tax Exempt organization with a 501 (c 3) Educational Status.

The following basic clause is suggested in making your bequest:

Form of Bequest

I give (devise) and bequeath to Heisey Collectors of America, Inc., a Non-Profit Corporation, chartered by The State of Ohio with an IRS 501 (c 3) Educational Status, having its office at 169 West Church Street, Newark, Ohio 43055 the sum of \$ _____ (amount) or all of my Heisey Glassware, or, the following items of my Heisey Glassware, or _____ % (_____ percent) of my residual estate to be used or disposed of at the discretion of The National Board of Directors of Heisey Collectors of America, Inc.

THE ABOVE IS IN RESPONSE TO REQUESTS FOR THIS TYPE OF INFORMATION

By Neila Bredehoff

This little hang tag is occasionally found with later Heisey vinegar and oil bottles such as the 1489 Puritan. I have seen a few with their original bottles. Apparently the Heisey Co. provided these to be packed with the bottles in gift boxes. The idea certainly was meant to be an added market incentive.

On the inside are several salad dressing recipes which were supplied through the courtesy of GOURMET magazine. We thought you might like to use an "authentic Heisey" recipe with your French dressing bottles - at least once! We haven't tried the recipes, but they do sound yummy.

Memo for Your Gift List...
 Here's a unique and beautiful gift to brighten the table... and help everyone from newest bride to oldest gourmet create perfect dressing! It's one of countless lovely gifts in Heisey Crystal...

A. H. HEISEY & CO., Newark, Ohio

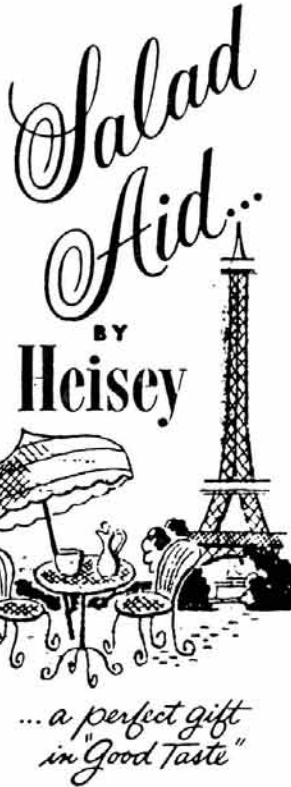

Spice up your salad and your table with Heisey Gift Crystal!

This sparkling French Dressing Bottle is as continental as a sidewalk cafe . . . a gourmet's delight for table and cuisine.

And for your pleasure . . . here are some very special recipes from The GOURMET Cookbook to give your family and guests the magic of good eating . . .

BASIC FRENCH DRESSING

Fill the Heisey French Dressing Bottle to the etched Vinegar mark with cider, tarragon, malt or wine vinegar. Add ¼ tsp. salt and ¼ tsp. ground white pepper. Shake well. Add to the etched oil mark 1½ cups olive oil. Shake vigorously. The Heisey leak-proof stopper allows thorough mixing so essential to good dressing.

Variations to taste:

Bellevue . . . For citrus fruit salad . . . 6 tblsps. sour cream, 1 tblsp. chopped chives.

Horseradish . . . For meat salad . . . 3 tblsps. well drained horseradish, 2 tsps. paprika, and a few drops of Tabasco.

Roquefort . . . For mixed green or endive salad . . . 2 rounded tblsps. Roquefort or blue cheese, crumbled well with a fork.

RECIPES COURTESY OF GOURMET—The Magazine of Good Living



The finest in Glassware, made in America by hand and nationally advertised for over fifty years.

A.H. Heisey & Co. NEWARK OHIO

The article about the Archives Yields New Information makes reference to a Rose color (pink) by Heisey around 1901. In my opinion, it is entirely possible that Heisey experimented with a Rose Pink color in 1901.

The color Rose had been in the glass industry for several years prior to 1901. McKee & Bros. Glass Company of Pittsburgh, Pennsylvania, was producing a Rose-Pink color in 1899. A 1898 advertisement of McKee & Bros. makes reference to their "Rose-Pink" glassware. They say "We challenge any other glass manufacturer to produce this color (Rose-Pink). Have you seen it? The winning color of 1899". I have seen the four piece table set in McKee's Apollo pattern in their Rose-Pink color.

Joe Lokay

McKee & Bros.
 PITTSBURGH, PA.

NO SCARCITY OF NEW DESIGNS WITH US.

SEVEN new and complete lines of Glassware, three new lines of Berry Dishes, a very complete line of Decorated Opal Novelties, new effects in Colored Glassware and Decorations, including Gold Decorations.

Our new decorating department is completed and in full operation. Our capacity in this direction is the largest in the world.

"Rose-Pink" Glassware.

We challenge any other glass manufacturer to produce this color. Have you seen it? The winning color of 1899.

SALESMEN: (New York: 66 West Broadway. San Francisco: 310 Front Street. BOSTON: 12 W. N. B. BOSTON. BOSTON: E. A. Rock.

WEST: (Thos. H. Lohr. P. J. Simons. A. J. George. R. P. Lewis.

PLATE 96

A McKee and Brothers advertisement during the year 1898, showing seven of their new patterns, viz: a) Apollo: see No. 43, this book: b) Orleans: see No. 45, c) Merrimac: see No. 47, d) Lenox: see No. 42 and also Plate 97, e) Stars and Stripes: see No. 44, f) Ardsley: see No. 46, g) Rainbou: see No. 48, also Pl. 89.

A. H. HEISEY & CO.



March 1, 1931

NEWARK, OHIO

To the Trade:

You will possibly recall that several seasons ago we first produced a new and unique and different item in what we call our two-handled mint, jelly, bon bon and cheese, to which we later added our two-handled sandwich, two-handled hors d'oeuvre and two-handled salad bowl. These items were all universal favorites, and consequently, always copied by unscrupulous manufacturers.

The trade as a whole, in their effort to meet competition, are too busy to pause to consider the ethics of the matter, and in consequence have been purchasing these items from other factories at reduced prices, and, we believe, inferior quality. It is bad enough to copy a house's exclusive product, but to cut the price we think is about the same as grand larceny. Consequently, we have not only taken the means to protect ourselves on design, but the government has granted us a mechanical patent for the manufacture of these articles. In other words, they have granted us a patent on our method of manufacture of a purely handled item, and our process of manufacture is the only means by which such an item can be made. Our exclusive rights are, therefore, obvious.

You can appreciate that to infringe on a mechanical patent is a very serious offense. Any manufacturer who now produces a two-handled item not only on the order of the items on the enclosed illustration, but any item, no matter what the design, that has two or more handles placed on the side, whether the handle be divided in two parts, or is single, is liable under our patent. And you, as a dealer, though innocent in your intention, if you continue to purchase such items, are equally as liable.

Therefore, in fairness to you and to ourselves, we take this opportunity to advise you that you lay yourselves liable to litigation should you purchase such items from any other manufacturer.

In the meantime, we will give you six weeks to unload what you already have in stock, and would advise that if these items are of sufficient interest to you in the future, you make such purchases of said items from us. We believe that in giving you this opportunity to dispose of the stuff you may now have that we have been fair.

Yours very truly,
A. H. Heisey & Co.

Sept. 2, 1930.

R. C. COBEL

1,774,871

APPARATUS FOR MAKING ARTICLES OF GLASSWARE

Filed April 17, 1928

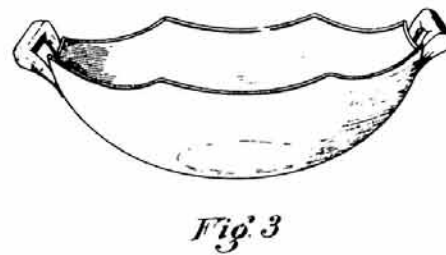
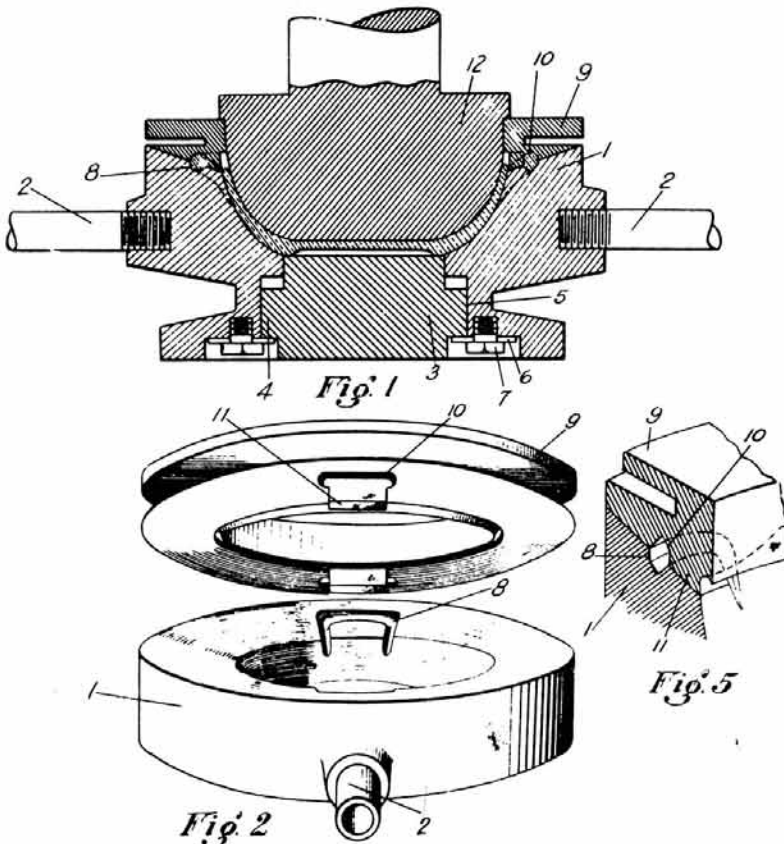

INVENTOR.
Ray C. Cobel.

BY
Edwin P. Cobel
ATTORNEYS.

A large variety of two-handled items in fine glassware is created by Heisey craftsmen in addition to those illustrated. All of them are evidence of the originality and leadership of Heisey designers. Recognition of Heisey's signal contributions to quality glassmaking is contained in the patent protecting the innovations in producing two-handled ware.

On this page and the next are reproduced illustrations of various two-handled items of Heisey's high quality glassware, in several patterns. Mints, jellies, bon bons, sandwich trays, etc., are shown. This is the type of item referred to in the letter and covered by the patent, of which a facsimile appears on the preceding pages. The patent grants to A. H. Heisey & Company exclusive rights in manufacturing two-handled pieces such as these.

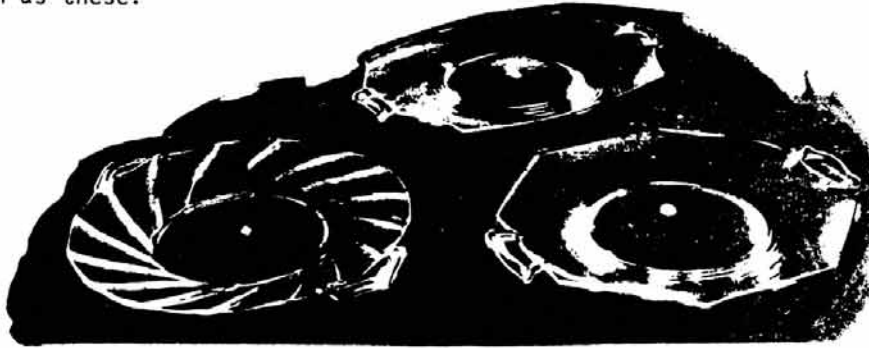

.....
In this view the following two-handled pieces of fine Heisey ware are illustrated: No. 1252, 12-inch Plate, No. 1229, Hors D'Oeuvre and No. 1229, Sandwich.
.....

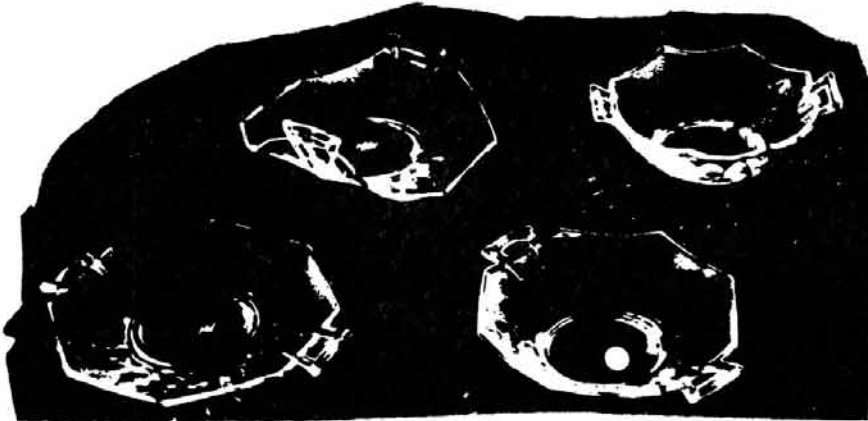

.....
The four two-handled pieces exhibited at the left belong to the No. 1184, diamond optic pattern. They are Bon Bon, Jelly, Cheese and Mint.
.....

.....
Representative items of the No. 1401, Lily of France design are shown opposite, namely: Sandwich Tray, Muffin and Square Sandwich.
.....



.....
The following two-handled items of the modernistic No. 1252 Heisey pattern are shown in the illustration opposite: Mint, Cheese, Bon Bon and Jelly.
.....

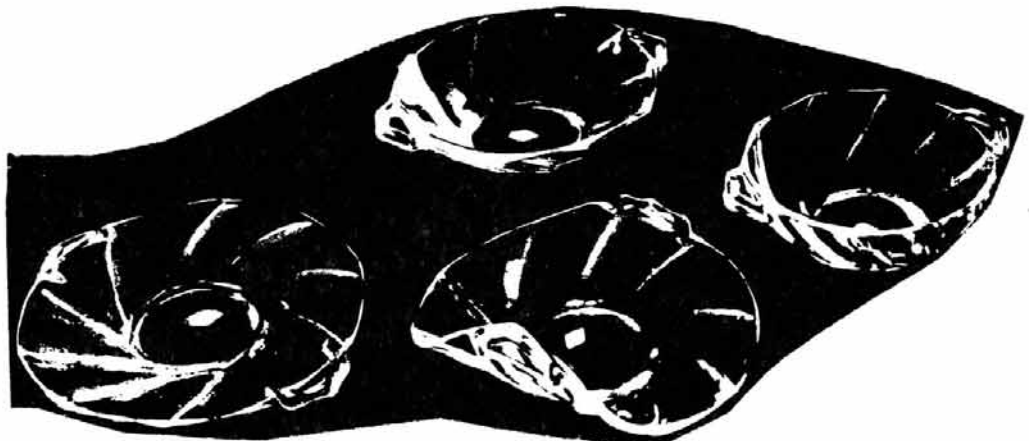

UNITED STATES PATENT OFFICE

RAY C. COBEL, OF NEWARK, OHIO, ASSIGNOR TO A. H. HEISEY & COMPANY, OF NEWARK, OHIO, A PARTNERSHIP

APPARATUS FOR MAKING ARTICLES OF GLASSWARE

Application filed April 17, 1928. Serial No. 270,754.

My invention relates to method and apparatus for making articles of glassware and, more particularly, to method and apparatus for making articles of glassware, such as dishes or the like, that are provided with suitable handles.

Heretofore, it has been customary to make handled glassware, such as dishes or the like, by forming the article by any of the well-known methods, for instance pressing, and then attaching and shaping the handle by hand.

The attachment of handles to glass articles by the hand method is a slow, laborious and, consequently, expensive operation, requiring workmen of a high degree of skill. In addition to this, such method has practically precluded the idea of making glassware having handles thereon of such shape and designs as to add materially to the ornamental effect of the ware.

Making handled glassware, such as dishes or the like, by forming the body portion and then attaching and shaping the handle has had the added disadvantage which results from attaching two pieces of glass together when such pieces of glass are at different temperatures. A perfect weld is seldom, if ever, formed between the pieces of glass under such conditions and, in glassware having handles thereon, this has increased the possibility of the handles breaking away from the body portion of the article.

One object of my invention is to provide a method and apparatus for making glassware, such as dishes or the like, having handles thereon whereby the handles are formed integrally and simultaneously with the body of the article.

Other objects of my invention may be seen in the following description, and the preferred embodiment of my invention may be seen in the accompanying drawings wherein similar characters of reference designate corresponding parts and wherein:

Figure 1 is a vertical sectional view of a mold and plunger constructed in accordance with my invention.

Figure 2 is a perspective view of a part of the main body portion of the mold and the mold ring which I employ, these parts being shown separated.

Figure 3 is a perspective view of a finished article that has been formed in my mold.

Figure 4 is a perspective view of a part of the article shown in Figure 3.

Figure 5 is a perspective view, partly in section, of a portion of the main body portion of my mold showing a mold ring assembled therewith.

Referring to the drawings, I have shown a press mold of the block type comprising a main body portion 1. This main body portion 1 is preferably provided with suitable handles 2 for convenience in moving the mold from place to place and for other reasons which will hereinafter appear.

Disposed in the lower part of the main body portion 1 is a valve 3, which valve preferably forms a substantial part of the bottom of the mold. Such valve has an annular flange 4 thereon fitting within a cutaway portion 5 in the base of the main body portion of the mold. The valve may be entirely removed from the main body portion 1 by removing the annular plate 6 which is secured to the main body portion by the screw bolts 7 or other suitable means and forms the lower wall of the annular groove 5. As will be seen by referring to Figure 1, the valve 3 is ordinarily in its lowermost position.

Referring to Figures 1, 2 and 3, it will be seen that the upper part of the main body portion 1 is provided with indentations 8 on its inner surface which are of the same general contour as the underside of the handle of the article which is to be formed in the mold. A mold ring 9 that is adapted to fit upon the top of the main body portion of the mold has indentations 10 in the surface thereof which are complementary to the indentations 8 in the main body portion when the two are in assembled relation. Lugs 11, depending from the mold ring 9, are designed to rest upon the inner surface of the main body portion adjacent the indentations 8. When in this position, they are complementary to the indentations 8 and 10.

In the operation of my device, a charge of molten glass is placed in the main body portion 1 of the mold and the mold ring 9 is positioned on the mold. When the mold ring 9 is in cooperative relation with the main body portion 1 of the mold, the indentations 8 and 10, together with the lugs 11, form a handle-shaping cavity into which glass is to be forced by the action of the plunger.

With the parts in this position, a plunger 12 is placed in the main body portion of the mold in the manner shown in Figure 1 and pressure exerted thereupon. Pressure on this plunger will cause the molten glass in the main body portion of the mold to flow upwardly around the plunger to form the body of the article and into the depressions 8 and 10 to form the handle. When the molten glass has become slightly cooled and has set sufficiently, the plunger may be removed, the main body portion inverted and the valve 3 operated to push the article out of the main body portion of the mold. The article may then be subjected to the usual finishing operations, such as bending the handles to any desired angle.

Referring to the preceding description and the drawings attached hereto, it will be apparent that I have provided a method and apparatus for making articles of glassware having handles thereon wherein the handles will be formed simultaneously with the forming of the main body portion of the article and integrally therewith. Such method will not only permit the making of handled glass-

ware wherein the handles may be of such shape and design as to add materially to the ornamental effect of the ware but will make possible the production of glassware wherein the handles have greater strength.

Having thus described my invention, what I claim is:

1. An apparatus for making an article of glassware with a handle thereon comprising a mold and a mold ring, said mold and mold ring having indentations therein designed to completely form a handle with an opening therein.

2. An apparatus for making an article of glassware with a handle thereon comprising a mold and a mold ring, said mold and mold ring having complementary indentations formed in the abutting surfaces thereof to form a handle, said abutting surfaces contacting with each other both outside of the handle and within the handle.

3. An apparatus for making articles of glassware with a handle thereon having an opening therethrough which comprises a mold and a mold ring having complementary indentations formed in the abutting surfaces thereof to form the handle with the opening therein, such abutting surfaces being free from interfitting projections.

4. An apparatus for making an article of glassware with a handle thereon comprising a mold and a mold ring, said mold and mold ring having complementary indentations formed in the abutting surfaces thereof to form a handle, each of said indentations forming substantially one-half of said handle.

5. An apparatus for making an article of glassware with a handle thereon comprising a mold and a mold ring, said mold and mold ring having complementary indentations formed in the abutting surfaces thereof to form a handle and such abutting surfaces being free from interfitting projections.

6. An apparatus for making an article of glassware with a handle thereon comprising a mold and a mold ring, said mold and mold ring having complementary indentations formed in the abutting surfaces thereof to form a handle with an opening therethrough, said indentations being of such form that the removal of the ring from the mold will leave the top and a portion of both the inner and outer sides of the handle exposed.

In testimony whereof I hereby affix my signature.

RAY C. COBEL.

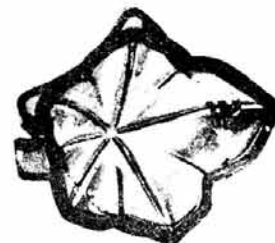

#1571 Ivy Leaf Nut
Unmarked

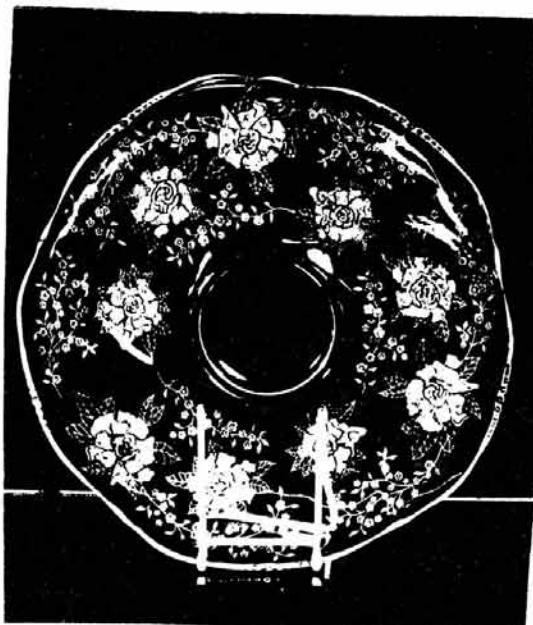

#511 GARDENIA etch.

1509 QUEEN ANN #511 GARDENIA
 _____ Triplex relish

In a list dated July, 1952, the following items were listed as etched with #511 Gardenia:

1598 COCKADE - See pg. 4 for photo for item
 _____ 13 in. Crimped bowl
 _____ 13 in. Gardenia bowl
 _____ 14 in. Torte Plate

1509 QUEEN ANN
 _____ Cream
 _____ Sugar

1519 WAVERLY
 _____ 7 in. Triplex relish

1495 FERN
 _____ 2 light Candlestick

134 TRIDENT
 _____ 5 in. 2 light candlestick

1509 QUEEN ANN 1519 WAVERLY
 _____ 11 in. Floral bowl _____ Gardenia bowl
 _____ 13 in. Gardenia bowl _____ Torte plate

THE "1776" COLONIAL PATTERN

CUTS ONE HALF SIZE



OIL AND VINEGAR SET

These cruets were made by Westmoreland. They are often mistaken for Heisey. These have been seen in pink and green. The only Heisey Colonial cruet in color that we know of is the #400 Colonial in Flamingo (or Rose) which the museum now owns. I have seen several of these and they were being offered for sale as Heisey. L.R.

The Westmoreland Company is now out of business.



In a club report last month there was a mention of Wig Wam pattern. The only thing I could think of then was the Wig Wam etch on stemware.

Marjorie Satryan wrote that she was referring to the early 124 tumbler which was named Wig Wam by Tom Bredehoft when he was writing his column on tumblers. It is pictured here.

My apologies to the Pittsburgh Club because I should have remembered the tumbler. L. R.

The first items to be made in #1496 Mahabar were cigarette boxes and ashtrays in Zircon and Sahara. The line was soon extended and became #1503 Crystalite. This is the company's notice of the change which was sent to stores, etc.

IMPORTANT NOTICE!

SEE PAGE 12

Effective immediately all items in the line formerly known as the No. 1496 line will be designated as

No. 1503

Please mark your records accordingly

A. H. HEISEY & COMPANY, NEWARK, OHIO

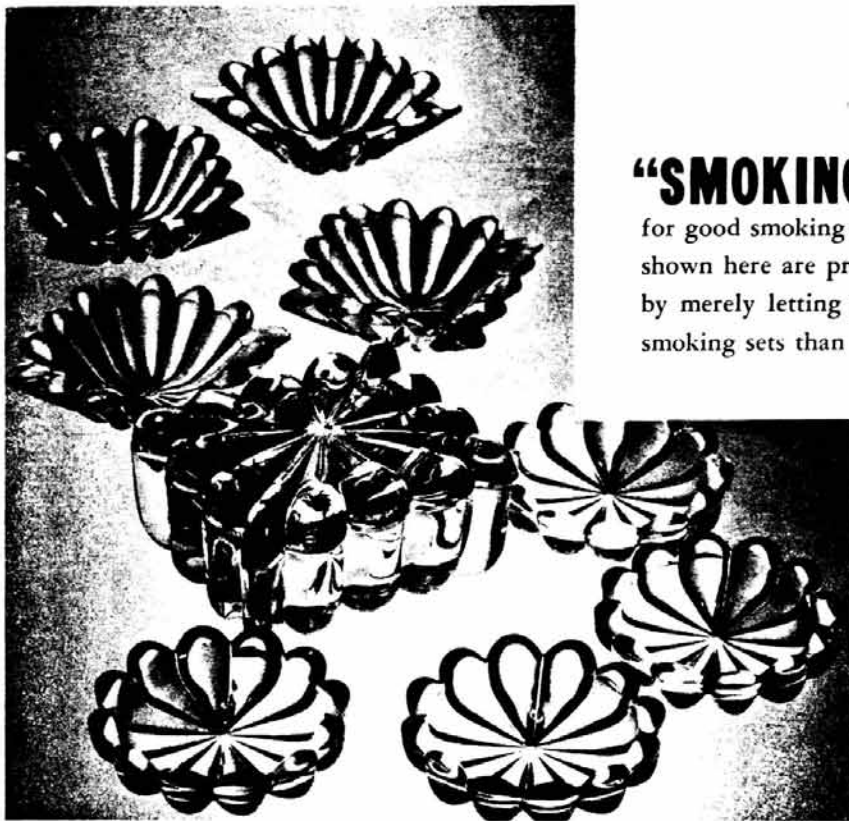

“SMOKING” HOT SELLERS There's *always* a sale for good smoking sets. But when real “smoking” hot numbers like the ones shown here are presented, you can increase your sales almost beyond belief by merely letting people see the items. We've never been more proud of smoking sets than these two.

At the left is the No. 1496 “Mahabar” Cigarette Box and Cover with square and round ash trays. These are made in Crystal, Sabara, and Zircon. Below is the No. 1489 Smoking Set with large and small ash trays.



MEET OUR NEW REPRESENTATIVES

We take great pleasure in presenting our four new representatives, all of whom have had quite a lot of experience in the glassware business.



FRED BOSWORTH travels out of the New York office



HOLT BERNI, representative in Washington and Oregon



R. G. HOW, Canadian representative



BLAS MITIDIERI, Cuban representative

GIFT BOXES AVAILABLE

| Carton No. | Description | Carton price each—Net |
|------------|---|-----------------------|
| 500 | 1489 Ash tray set—1 large—4 small ash trays | 10c |
| 501 | 1469 Cigarette set—1 1469 4" sq. cig. box and cover | 7c |
| | 4 1469 Ash trays | 7c |
| 502 | 1469 Cigarette set—1 1469 Rd. or sq. cig. holder | 7c |
| | 4 1469 ash trays | 7c |
| 502 | 1486 Cigarette set—1 1486 Rd. cig. holder | 7c |
| | 4 1486 Ash trays | 7c |
| | or 1 1486 Rd. cig. holder | |
| | 4 1489 Ash Trays | |
| 503 | 1496 Cigarette set—1 1496 Cig. box and cover | 10c |
| | 4 1496 Ash trays | 10c |
| 504 | 1469 Ind. sugar and cream and tray | 7c |
| 505 | 1469 Mayonnaise—6" plate and ladle | 9c |
| 506 | 1401 console set —1 1401 11" floral bowl | 25c |
| | 2 134 candlesticks | 10c |
| 507 | 1495 Relish or 1495 Jello Dish | 6c |
| 508 | 1469 1/2 2 handle cheese dish | 6c |
| | or 1469—3 handle jelly | |
| | or 1469 1/2—2 handle jelly | |
| 509 | 1488 3/8 doz. 2 lt. candelabra and prisms | 15c |
| 510 | 1469 Console set—1 1469 9" sq. nappy | 15c |
| | 2 1469 2" sq. candlestick | 12c |
| 511 | 1469 11" Rd. 3 compt. relish | 11c |
| 512 | 1469 star relish | 9c |
| 513 | 1469 large sugar and cream | 7c |
| 514 | 1469 6" cig. box and cover | 7c |
| 515 | 1469 7" 2 compt. relish | 6c |
| 516 | 1469 6" square ash tray | 9c |
| 517 | 1469 10 1/2" Oblong Tray | 8c |
| | or 10 1/2" 3 compt. Oblong Relish | 8c |
| 518 | 1469 Celery and Olive | 8c |
| | or Celery | |
| 519 | 1469 1/4—2 1/2 Doz. Large Coaster | 8c |
| 520 | 3041—1 1/6 doz. Candelabra and Prisms | 12c |

Glassware—List prices, less regular discount

Table Talk

A. H. HEISEY & CO., NEWARK, OHIO



SEPTEMBER, 1937

"All Dressed Up," and SOME PLACE to Go!
... in these smart new Gift Boxes

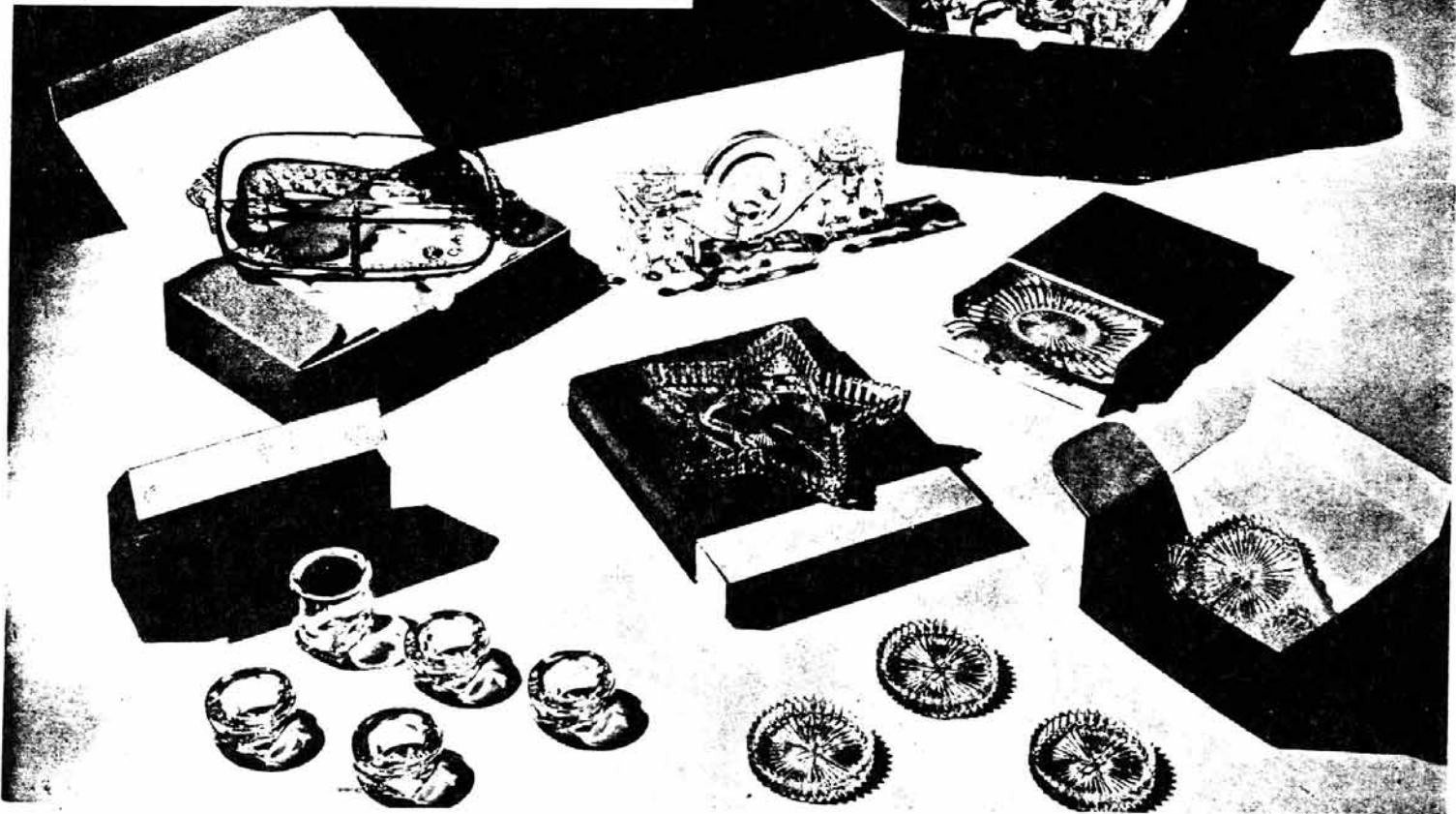

● These *most attractive* red and white gift boxes will help *you* make a big increase in your glassware sales. They are just the thing for which your customers have long been waiting. They offer a wide choice of glassware in various assortments—all of which make splendid gifts at any season and for any occasion.

The boxes enable you to re-ship without packing—and offer protection to the glass while delivering—as the boxes are quite strongly constructed. May we suggest that you study, carefully, the list of gift boxes and their contents listed on page four? The sooner we receive your order the better service we can give you on these boxes.

PHOTOS FROM JUNE DISPLAY

By Jim Jones

1. #1295 Bead Swag goblet in Custard
2. #1295 Bead Swag tankard in Opal
3. A variety of Custard glass items
4. (4) #4045 ball vases in Cobalt and #1433 Thumb-print & Panel candlesticks
5. #365 Old Queen Ann punch bowl

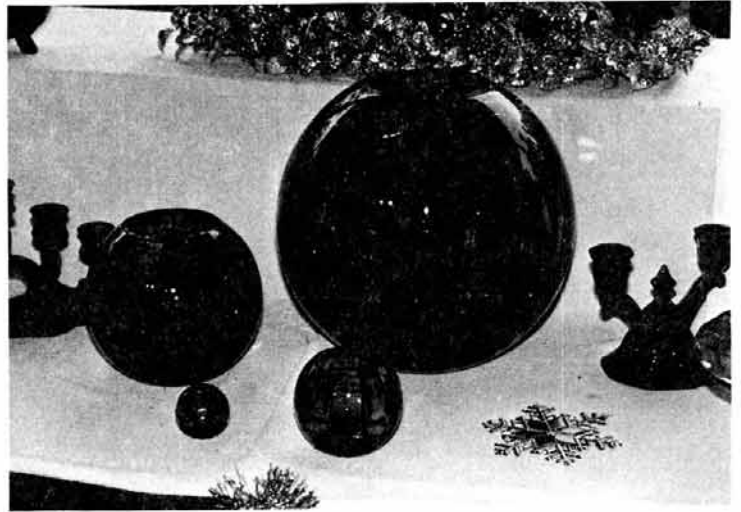

THE TWO SISTERS MINING COMPANY

By Neila Bredehoff

From some new archives recently acquired we have learned that A. H. Heisey and James E. Duncan were in partnership in the Two Sisters Mining Company. The only location given on the stock certificate is listed as Pittsburgh, Pa., but it is possible that the actual company operated in the west. The Heiseys, at least, did own some land and had mining interests in the west, especially in Denver, Colorado. It is also possible that the Duncans held similar interests since one of the Duncan brothers, Wilbur, was treasurer of a mining company in Cheyenne, Wyoming, before his death in 1886.

Apparently the brothers-in-law, James E. Duncan and A. H. Heisey, were involved in several financial ventures as partners. The most obvious, of course, was the Geo. Duncan & Sons Glass Co. of Pittsburgh from 1875 to 1892. They also purchased land near Pittsburgh and developed it partially and sold lots from it in the late 1800's. Now we find that they also held mining interests together.

What I find very interesting is the name of the company, Two Sisters. This becomes more interesting when reading the reverse of the certificate which says: "Know all men by these presents, That I do hereby appoint Susan N. Heisey attorney irrevocable for _____ to sell and transfer to _____ of the within-named shares, with power to appoint one or more attorneys under _____ for that purpose.

"Witness my hand and seal this 16 day of Nov 1886"

[Signed] A. H. Heisey"

"Sealed and delivered in the Presence of D. C. Snyder"

To me this seems to indicate that Heisey and Duncan established the company but listed their wives as official participants and thus the inspiration for the company name.

These certificates are an interesting sidelight to the lives of these two men and the glass companies they established. One can only assume that at one time, certificates existed with the signature of Mrs. Duncan in the same capacity as Mrs. Heisey.

In case it is impossible to read the front of the certificate the wording is as follows:

"Two Sisters Mining Company

No. 143 - 10- Shares

Pittsburgh, PA. May 4th 1886

This certifies that A. H. Heisey is entitled to Ten shares of the capital stock of The Two Sisters Mining Company transferable on the books of the Company by endorsement hereon and surrender of this certificate. Witness the Seal of said Company and the signatures of the President and Secretary. Stock Full Paid and Non-Assessable.

[Signed] James E. Duncan Secretary A. H. Heisey President"

NOTE: Words in italics were handwritten.



Know all Men by these Presents, That I do hereby appoint Susan N. Heisey attorney irrevocable for _____ to sell and transfer to _____ of the within-named shares, with power to appoint one or more attorneys under _____ for that purpose.

Witness my hand and seal this 16 day of Nov 1886

A. H. Heisey (SEAL)

Sealed and delivered in the Presence of D. C. Snyder

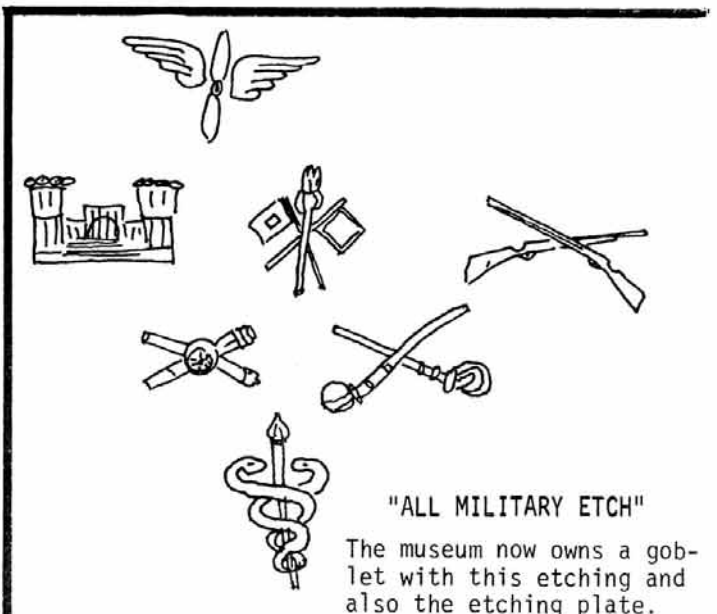

CLUB NOTES

NORTHWEST HEISEY COLLECTORS CLUB

By Nancy Alderson

The October meeting took place at the home of Don & Glenna Wehmeyer of Seattle. Vice President, Jaime Robinson, presided over the meeting, followed by the traditional raffle. Using mostly their own large collection for the program, our hosts presented a very informative program on tumblers and shot glasses. We learned that according to Webster's Dictionary, a tumbler is a flat bottomed glass having no handle, foot or stem, but did originally have a rounded bottom, thus the name tumbler. Twenty-eight tumblers included such patterns as: Flamingo Twist; Sahara Old Sandwich; Limelight Whirlpool; #1417 Cobalt; #1415 Twentieth Century in Tangerine. Also, to name a few in Crystal: #7019 (this is 7000 Sunflower) Diamond Crystal; Victorian; Punt Band; Puritan; Crystolite. Ten bar glasses completed the program and included Banded Flute, Pricilla, Hartman, Rib & Panel, Ridgeleigh, Coleport, Coronation, and a beautiful little #6031 with Moonglo cut. "Show and Tell" was great, followed by dessert and the announcement that the November meeting would be held in Des Moines, Washington.

Northwest Heisey Collectors met the first Saturday of November at the home of Nancy Alderson with a large turnout, including two new members and some guests. Jaime Robinson opened the meeting; minutes were read by Secretary, Glenna Wehmeyer; the Treasurer's report was given by Maxine Johanson. After a short business discussion, the program of "HEISEY ADVERTISEMENTS" got everyone's attention. Members went through old cook books of the 20's and 30's to find food frequently displayed on Heisey - National Geographic, China & Glass, Crockery & Glass, Women's Home Companion, just to name a few. One of the most recent was a 1988 Thanksgiving full page color ad in the Seattle Times with turkey, cranberry sauce, etc. and they showed the good taste to select a Crystolite dish to enhance the green and black olives. The meeting closed with dessert and glass talk. It was decided the December meeting would be a potluck at the home of Ken and Wanda Heikes in Tenino, Washington. The program will be Christmas arrangements using Heisey glass.

For Club information in this area call Don Wehmeyer at 206-546-2812.

Happy New Year from the Northwest Heisey Collectors

GATEWAY HEISEY COLLECTORS CLUB OF PITTS-

BURG, PA

By Phyllis Freier

We, The Gateway Heisey Collectors, made our way to the south hills from the north hills, Beaver county, West Moreland county, the city of Pittsburgh, and Allegheny county, for the November meeting at the Hallborgs.

Harry Freier, our president, announced that Joe Lokay is the Chairman of the nominating committee. LaVerne Lokay, Rick Stoll, and Mary Alice Stoll are the committee members.

It was decided to present the Collector's Encyclopedia of Fry glassware to the National Heisey Glass Museum. This book has just been published by the H. C. Fry Glass Society.

Joe Lokay presented an informative program on the Prince of Wales pattern. Many pieces of the pattern were shown.

Show and Tell revealed several exquisite pieces: a Crystolite cigarette box in Sahara; a 12" Lariat urn and cover with a Wheat cutting; an Emerald Winged Scroll sugar bowl and cover; a Queen Ann (1509) individual sugar and creamer with the Belle-Le-Rose etch. All brought forth many ohs and ahs.

Our blind and silent auction was a success. It really looked like Christmas with all the wrapped packages. There were tea towels, salt dips, mugs, cards, stationery, and lots of goodies in those boxes but, no one had x-ray vision.

After a delicious dinner we made our way home in the dark of a November evening.

The members of the Gateway Heisey Collectors Club hope you all had a happy holiday season.

GULF COAST HEISEY COLLECTORS CLUB (FLORIDA)

By Virginia Johnson

The November meeting of the Gulf Coast Heisey Club was held at the home of Calvin and Dorothy Meyer in Gainesville on Wednesday, November 15, at 2:00 p.m. This was our first meeting at the Meyer home (they have "immigrated" from Michigan) and since we all came from quite a distance, we planned to remain overnite in Gainesville. There were 17 of us present, coming from Bradenton, Seffner, Venice, Seminole, Spring Hill, Parrish and Clermont. The Myers have recently moved into their beautiful new home and we all enjoyed being there and seeing some of their Heisey which is displayed so well. We were hospitably greeted with a fruit punch from a Crystolite punch bowl served in Crystolite punch cups, plus fruit and other snacks.

During our business meeting, our President, Jack Grenzeback, informed us that we had 16 of our members attending the June Convention, and 15 attending the dinner. We are only two years old and have 23 members so, we are very proud of the representation we had in June.

A sad note to our club is the death of Bruce Montgomery in September, who was a charter member.

Our next meeting will be held January 18, Thursday, at 11:00 a.m., at the home of Odell and Virginia Johnson in Bradenton, and we will have lunch-snacks at the Johnsons rather than going out to lunch. The members feel that we "lose valuable time" with a long lunch and that we will be able to utilize our time better by doing our eating, our program, and our socializing at one place.

Our program this time consisted of "Show and Tell" by members who brought their newest finds or their favorite pieces of Heisey. One member brought a #310 Ring Band custard with a poppy painting rather than the usual roses. This appears to be a not so common decoration. One member brought a fake small pitcher, which had fooled him and he says that goes in his "DUMB BOX". I think we all have a box by that name! The Meyers had a slide show from the Museum consisting of slides of Heisey patterns and we were supposed to identify such. We didn't do too

continued on next page

. . . . CLUB NOTES continued from preceding page

well, but we decided it was because the slides focused on such small parts of the pattern.

After our dinner at a nearby restaurant, most of us returned to the Meyers for apple cider and pumpkin pie served on Crystolite and Moongleam Twist, and more socializing. We all agreed it was great to meet again after a summer when many of us are gone or traveling. Please find the notice of our January meeting in this issue. We welcome visitors and bring some glass for our Silent Auction---and your money, all for the HCA Museum.

HOOSIER HEISEY CLUB

Edward P. Kult

The Hoosier Heisey Club met at the Warren Library in Indianapolis on Saturday, November 18, 1989, with 29 members and visitors in attendance.

President, Kim Carlisle, conducted the short business meeting with Secretary, Rachel Wolfe, reading the minutes and financial report.

The program consisted of several presentations. The slides and text of Jim Earnshaw on "Syrups" was given by Dave Stratton. Irene Pope reviewed the background of the color, Alexandrite. Bill Phillips assisted in the slide show, "How Well Do You Know Your Heisey", followed by the Show and Tell table.

Refreshments reflecting the Thanksgiving theme were served.

Tentative date for the next meeting is March 3, 1990. Happy New Year!

Ed. Note: We just heard that the Hoosier State Club now has 50 members. This is a fairly new club which was chartered this past June.

GATEWAY HEISEY COLLECTOR'S CLUB - PITTSBURGH

Marge and Tom Satryan's home was aglow with Christmas lights and decorations when the Gateway Heisey Collector's Club met in early December. All that beauty and the welcoming fire in the fireplace put each of us in the Christmas spirit as soon as we stepped into the house.

Before the business meeting the Satryans served us a wonderful dinner, and to make it more special, it was served on their Flamingo Twist dinner set.

After dinner we all adjourned to the family room where President, Harry Freier, conducted the business meeting. The following slate of officers was presented by the nominating committee and was unanimously accepted: Pres, Marge Satryan; Vice Pres, Phyllis Freier, Sec, LaVerne Lokay; Treas, Joe Lokay. It was announced that the club had presented the newly published book The Collector's Encyclopedia of Fry Glassware by the H. C. Fry Glass Society to the museum library. We in the Pittsburgh club are especially interested in Fry glass, as well as Heisey, since it was produced in Rochester, Pa, Beaver county, Pennsylvania, a town in our area. Glassware of excellent quality was produced here from 1901 through 1933. It is a very fine book with the history of the Fry Co. and its founder, Henry Clay Fry. It contains many excellent pictures in black and white and in color.

Phyllis Freier presented a very informative pro-

gram on patterns related to or produced at the same time as Crystolite. Sometimes these patterns were shown in advertisements along with Crystolite. She also showed us Heisey patterns that look like they could belong to the Crystolite line and patterns by other companies that could be mistaken for Crystolite. Her talk was documented by eight pages of pictures of these various categories.

The number of items for Show and Tell was not as large as usual. I guess everyone is waiting for Santa. However, a beautiful Sunburst spooner was shown that will go with the owner's covered butter dish; also, a ten inch Twist utility dish in Flamingo which was unusual because it has four feet. In Vogel's and Neila Bredehoft's books, the catalog reprints indicate that this dish has three small feet. Does this mean that one of our members has a rarity? Several other pieces were brought for confirmation as to their maker. Among them were some pieces in a pink shade that is very much like Flamingo. I guess they will have to be taken to the convention to the experts for identification.

Wouldn't you like to join our club? You can contact us through HCA.

By
Margaret Reed

GULF COAST HEISEY CLUB

MEETING THURSDAY, JANUARY 18TH, 11:00 A. M.

AT THE HOME OF ODELL AND VIRGINIA JOHNSON

BRADENTON, FLORIDA

VISITORS WELCOME!

PLEASE CALL (815) 792-0604

WRITE 6909 - 10TH AVE. W., 34209

IMPORTANT NOTICE

TO STUDY CLUBS

Burl Whaley, Project Coordinator, is requesting that any club which is currently working on a project write to him and report what the project is and its present status.

He would also like to have requests for new projects sent directly to him to avoid any confusion.

WRITE TO: Burl Whaley
300 International Drive
Pataskala, Ohio 43062

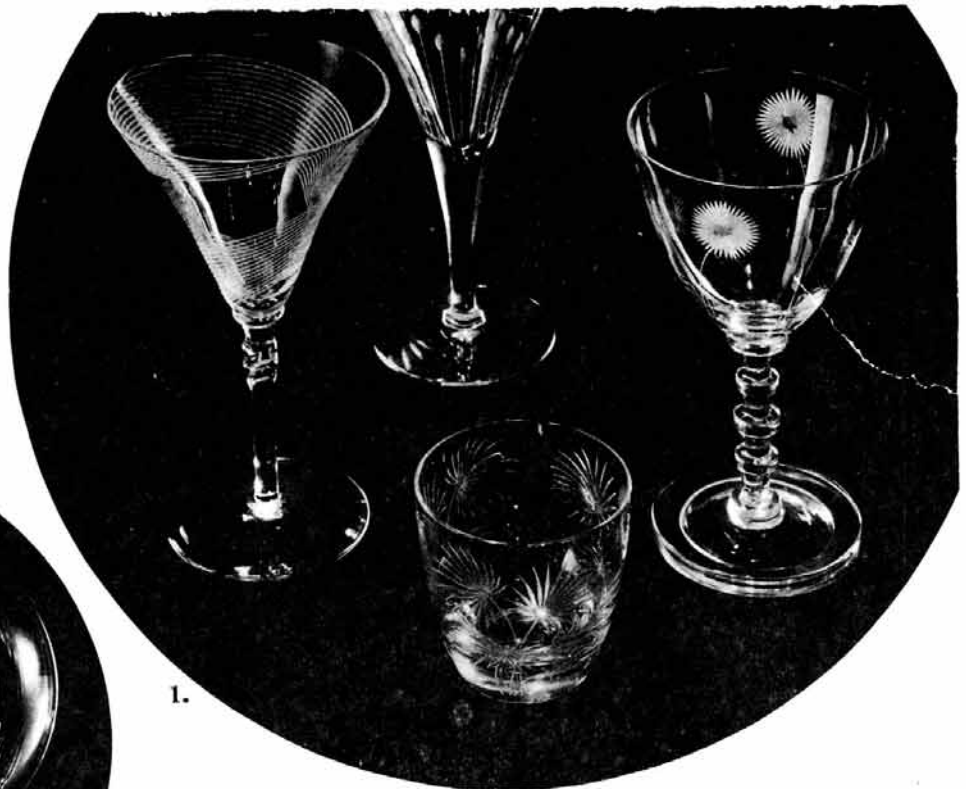

1.



2.

SPOT NEWS

from the glass and china market

Dates of Kohinoor pattern
approximately 1937 - 1939

1. Four modern glass shapes and decorations. The well-proportioned goblet left is *Ski*, an abstract Cataract-*Sharpe* design inspired by skiers' tracks. From Wallace and Bowes. At the top is Morgantown Glass's goblet *Arabia*, with the vertical lines of the decoration accentuating an illusion of natural growth from the base. At the right is the *Straw Flower* pattern on Cambridge Glass's new *Pristine* goblet. In front is *Lido*, Fostoria's new etched pattern on their rounded *Standish* tumbler.

2. Blank goblet, sherbet and salad plate in the *Pristine* line from Cambridge Glass. The base is thick at the edge for stability and balance, but is hollowed underneath in a circle. The ringed stem repeats the circle motif.

3. *Rings of Saturn*, a new swirl optic group from Heisey. A large diamond joins the hexagonally cut stem to the round base of the stemware, and gives the name of *Kohinoor* to the shape. *Kohinoor* comes in colors and many other types of decoration, including new cuttings and etchings. Designed by *Walter Von Nessen*.

4. Examples of Duncan and Miller's new nautical line. The straight tumbler, with either plain or frosted foot, comes in many nautical designs.



3.



1989 GLASS DONATIONS FOR THE GIFT SHOP

1. \$119.00 donated by Harry L. Allen
2. \$100.00 donated by Irene Walton
3. \$75.00 donated by Joann D. Hagerty

1989 DONATIONS TO THE ENDOWMENT FUND

- #36 HCC of Southeastern Massachusetts - \$25.00
 #44 National Capital HCC - \$25.00
 Charlotte E. Berry - \$25.00
 Joyce Rhode - \$25.00

1989 DONATIONS FROM INDIVIDUALS

1. #352 Flat Panel cruet & #2052 bar glass with Windsor cutting donated by Harry Allen in memory of his wife, Evelyn.
2. Three books for the library donated by Bill & Marge Rosse
3. Reprint of a Heisey catalog and 200 copies of the Candlestick Field Guide donated by Marv and Lois Jacob

MY LAST POEM?

By Liz King

The HCA Dinner in early September
 Is certainly one that I'll always remember
 As I ended my poem, to my great surprise
 Everyone suddenly began to rise!

A standing ovation and my very first!
 It wasn't the best, nor yet the worst
 Poem I've written, but I thought at the time
 Let's leave it forever and write no more rhyme

So to all, Merry Christmas and Happy New Year
 Enjoy parties and presents and punch bowls of cheer
 And wherever you go keep Heisey in mind
 And let Janet C. know when you make a big "find"

DATES TO REMEMBER

| | | |
|-------------------------|---|-----------------------|
| March 3, 4 | Glass Show San Mateo, California | Golden Gate HCC |
| March 9, 10 | Annual All-Heisey Auct Apple Tree Auct Center | HCA |
| March 11 | Starlight Flea Market Starlight School | Land of Legend HCC |
| March 17, 18 | All-Heisey Show, Silver Spring, MD | Natl Capt HCC |
| June 14, 15, 16 & 17 | 19th Annual Convention 20th Annual Glass Show & Display, Newark, Ohio | HCA |
| June 9, 10 16 & 17 | Flea Market On the Square | Buckeye HCC |

1990 CONVENTION SHOW

JUNE 14, 15, 16, 17, 1990

It is time for Heisey dealers to reserve space in the 1990 Convention Antique Show. The theme for 1990 will be "Heisey Salutes the Nineties". We are planning a fantastic show and have a waiting list left from last year. However, plans do change at the last minute and if you are interested, please let the Show Committee know as soon as possible.

Please respond to:

Jim Reynolds & Frank Harper
 '90 Convention Show Committee
 1010 13th Street
 Racine, WI 53403

1489 PURITAN



Brand-new is this distinctive hexagonal center bowl and matching candlesticks -- fashioned in thick, heavy Crystal by A. H. Heisey and Company. 1941.

We have the ash tray in this pattern in the museum. It is beautiful glass. We've never seen the candlesticks.

18 ANNUAL

STARLIGHT FLEA MARKET

ANTIQUES AND COLLECTORS SHOW

At
Starlight School
116 N. 22nd Street
Newark, Ohio

March 11 from 9 am - 4 pm

Antiques
Heisey Glass
Crafts
Pottery

Benefits—Starlight School & Heisey Museum
Sponsored by— Land of Legend Study Club

DONATION
\$1.00

(614) 366-5163

A PRODUCT OF DOUGLAS ENTERPRISES

* FOREVER HEISEY PH; 614-344-5955
 * JAN & NORM THRAN
 * 1663 Londondale Pkwy.
 * Newark, OH 43055

1990 SHOW DATES:

* Jan 12, 13, 14 Will Rogers Col Ft. Worth, TX
 * Jan 17, 18, 19 Fairgrounds Tulsa, OK
 * Jan 27, 28 Ft. Bend Fair-grounds Rosenberg, TX
 * Feb 2, 3, 4 Brazos Center Bryan, TX
 * Feb 10, 11 Fairgrounds, Arts & Crfts Bldg Columbus, OH

* Always plenty of Heisey animals, colors, stemware and etchings in stock. All SASE inquiries answered. Send wants - we search. We buy one piece or collections including estates.

CLASSIFIED ADS

* WANTED: Emerald Beaded Swag. E. J. Cox, Box 367, Spavinow, OK 74366. Phone 918-589-2859.

* WANTED: Collector desires Flamingo 1401 Empress punch cups to go with 1401 Empress 15" punch bowl. Also needs glass ladle for same. Must be mint. Jim Maguire (516) 326-2447 anytime, leave message.

* WANTED: ANIMALS, ANIMALS, ANIMALS, ANIMALS, Heisey Amber giraffe, Honey Amber rooster and flying mare, Cobalt colts and colored limited edition Heisey and Imperial animals. Plaster/Wax animal models. Collector, P.O. Box 1115, Newark, Ohio 43055. Phone (614) 349-4714.

* FOR SALE: 58 pieces of Heisey Rose. Send SASE for list. June Wirtanen, 2128 East 4th. Street, Duluth, MN 55812. Phone (218) 724-0238.

* FOR SALE: (5) Ice tea and (1) cocktail, \$25 each; (2) cordials, \$75 each. All #3408 Jamestown stem with #497 Rosalie etch. Toni Wangerow, 10530 Chaney Avenue, Downey, CA 90241. Phone (213) 923-6633.

* FOR SALE: Heisey by Imperial. All articles purchased from the museum in 1980. Milk Glass rooster, hen and two chicks, rabbit, two bunnies and scottie; two Jade green tiger paperweights; Crystal frosted madonna; baby elephant pink frosted; baby elephant pink carnival; three pairpoint cup plates; elephant handled mugs, two carnival and 7 Crystal; seven Old Williamsburg bells; Victorian belle's - four frosted and six plain; seven pair of salt & pepper shakers; three light blue mallards - wings up, wings half, wings down; three light blue rearing colts dated 1979; three standing colts; Blue cygnet. Total of 52 pieces for \$650 plus postage. If individual pieces are wanted, please send your offer with SASE. Frank DiDomizio, RD#2, McAlisterville, PA 17049. PH: (717) 463-3340.

* FOR SALE: Available subject to prior sale twenty-four pieces of Shasta Stem Daisy pattern. Write R. W. Bachman, P.O. Box 1385, Sedona, Arizona 86336.

Old Morgantown Glass Collectors' Guild



\$20.00 CHARTER MEMBERSHIP
includes

- One limited edition clear glass paperweight cast from an original 1930s Morgantown mold.
- One year's membership in the Old Morgantown Glass Collectors' Guild. Annual dues will be \$15.00 after first year.
- A quarterly Newsletter to member households. Each issue will contain previously unpublished material re The Economy Tumbler Company, The Old Morgantown Glass Works, and The Morgantown Glassware Guild.
- Other benefits to be listed in a letter of acknowledgement forwarded to each charter member upon receipt of the information listed below.

Please register me as a Charter Member of the OLD MORGANTOWN GLASS COLLECTORS' GUILD. My \$20.00 Membership Fee is enclosed.

Name (please print) _____

Street Address (D.P.S.) _____

P.O. Box (if applicable) _____

City _____

State _____

Zip _____

A.C. & Phone # _____

THE FOLLOWING MEMBERS OF MY HOUSEHOLD REQUEST ASSOCIATE MEMBERSHIP AND PRIVILEGES FOR AN ANNUAL FEE OF \$2.50 each.

TOTAL # Memberships: _____

AMOUNT ENCLOSED: \$ _____

(Name or Money) Other: _____

MAIL TO: OLD MORGANTOWN GLASS COLLECTORS' GUILD
P.O. Box 894 - Dept. HN Morgantown WV 26507-0894

WILLEYS ANTIQUES
1110 CANNON ROAD
FRAZEYSBURG, OH 43822

PH: 614-828-2557

Over 2,000 pieces of Heisey for sale. Stemware and dinnerware matching service. Lots of colors, etchings and cuttings. Send want list and SASE. All letters answered if a SASE is enclosed.

SHOW DATES

1990

| | | |
|----------------|--------------------------|---------------|
| Jan 12, 13, 14 | Will Rogers Coliseum | Ft.Worth,TX |
| Jan 19, 20, 21 | Civic Center | McAllen, TX |
| Jan 26, 27, 28 | Y. O. Ranch Hilton Hotel | Kerrville, TX |
| Feb 2, 3, 4 | Brazos Center | Bryan, TX |
| Feb 9, 10, 11 | Palmer Auditorium | Austin, TX |
| Feb 16, 17, 18 | Rapides Parish Col | Alex, LA |
| Feb 23, 24, 25 | Yamatorium | Opelousas, LA |
| Mar 3, 4 | St. Bernard Cult Center | Chalmette, LA |
| Mar 17, 18 | Armory Place | Silver Spr MD |

SEE YOU AT THE SHOWS, Mildred & Harold Willey

DONALD P. BEAN
36 HARDING STREET
MILFORD, MA 01757

PH: 508-473-0561
SHIPPING EXTRA
* = MARKED

| | |
|--|-----------|
| 150 Banded Flute 4" chamberstick* | \$42.00 |
| 1540 Lariat (1 only) 3-lite candlestick | 45.00 |
| 1433 Thumbprint & Panel (1 only) 2-lite stick | 22.00 |
| 1469 Ridgeleigh 2" sq ftd candlestick | pr 35.00 |
| 1503 Crystolite 3-lite candlestick | pr 50.00 |
| 341 Puritan 3 oz cocktails* (7) | all 45.00 |
| 451 Cross Lined Flute jelly comport* | 35.00 |
| 451 Cross Lined flute 5" vase* | 35.00 |
| 1533 Wampum console set w/12" bowl & pr of 1-lite sticks | set 75.00 |

STILL WANTED - COVER FOR LARGE FANCY LOOP POTPOURRI

L. A. MANESS
RT. 1, BOX 552
ASHLAND, VA 23005

PH: 804-798-1825
P & I RATE \$3/CTN
H = MARKED

VISA/MASTERCARD WELCOME

| | |
|--|------------|
| 373 Colonial 1½ oz wine, H (4) | ea \$15.00 |
| 1503 Crystolite cov'd mustard, H w/small glass spoon | 52.00 |
| 352 Flat Panel oyst'r c'tail 8" plate, H (6)ea | 25.00 |
| 393 Narrow Flute cov'd mustard, H | 45.00 |
| 351 Priscilla 4 oz cruet, H | 42.50 |
| 341 Puritan 3 oz wine, H (4) | ea 22.50 |
| 1252 Twist ind nut dish, Flamingo, H (2) ea | 19.00 |
| 1425 Victorian 9 oz low ftd goblet, H (4)ea | 22.50 |
| 1425 Victorian 3-part relish, H | 37.50 |

* CLASSIQUE GLASS CO.
* P.O. BOX 52572
* TULSA, OK 74152

PH: 918-744-5409
UPS & INS EXTRA
MOST MARKED

| | |
|---|-------------|
| * 134 Trident candlestick, Sahara . . . | pr \$135.00 |
| * 433 Greek Key oval individual cream & sugar - scarce! | 195.00 |
| * 433 Greek Key punch cups (10) | ea 15.50 |
| * 439 Pied Piper/3350 Wabash goblet (7) | ea 26.00 |
| * 439 Pied Piper/3350 Wabash sauc champagne (10) | ea 23.00 |
| * 1401 Empress Antarctic Etch 8" h'lded vase | 125.00 |
| * 1401 Empress 6½" B&B round plate (9) | all 55.00 |
| * 1425 Victorian punch cup (5) | ea 12.50 |
| * 1425 Victorian small compote | 37.50 |
| * 1425 Victorian 2½ oz wine (5) | ea 24.00 |
| * 1425 Victorian 12 oz ftd soda (5) SC | ea 35.00 |
| * 1495 Fern 2-lite candlestick/bobeche/prisms | pr 95.00 |
| * 1533 Wampum 13" gardenia bowl | 75.00 |
| * 3362 Charter Oak goblet, Moongleam (4) | ea 23.00 |
| * Animal Child's Toy Horsehead 1" Crystal (2) | ea 85.00 |
| * Animal Child's Toy Horsehead 1" Frosted (2) | ea 90.00 |
| * Animal Giraffes - 1 head rgt & 1 head rear | ea 225.00 |
| * Heisey Rose Stem champagne - not etched (6) | ea 22.00 |

HAPPY NEW YEAR TO ALL & THANKS FOR THINGS PAST!!

H & R DIAMOND H
HELEN - BOB RAREY
1450 WHITE ASH DRIVE
COLUMBUS, OHIO 43204

PH: 614-279-0390
AFTER 5:30 P.M.
UPS & INS EXTRA
* = MARKED

Heisey Punch Cups

| | |
|--|------------|
| * 300½ Peerless* (2) | ea \$10.00 |
| * 305 Punt & Diamond Point* | 15.00 |
| * 325 Pillows* | 37.50 |
| * 337 Touraine* (8) | ea 9.50 |
| * 339 Continental* (2) | ea 10.00 |
| * 350 Pinwheel & Fan* (4) | ea 15.00 |
| * 357 Prison Stripe* | 22.50 |
| * 397 Urn* | 15.00 |
| * 407 Coarse Rib* (5) | ea 12.50 |
| * 411 Tudor* (Rib & Panel) (5) | ea 12.50 |
| * 429 Plain Panel Recess* | 15.00 |
| * 1160 (Flared)* (3) | ea 7.50 |
| * 1159 Custard* Rose Decor | 27.50 |
| * 1205 Fancy Loop (3) | ea 12.50 |
| * 1235 Beaded Panel & Sunburst | 15.00 |
| * 1401 Empress* (8) | ea 17.50 |
| * 1425 Victorian* (8) | ea 9.50 |
| * 1469 Ridgeleigh* round (5) | ea 9.50 |
| * 1506 Whirlpool* (4) | ea 12.50 |
| * 1567 Plantation* (2) | ea 15.00 |

DEALERS DIRECTORY MAX. 5 LINES/12 MONTHS/\$25.00

We assume no responsibility for error in these ads after the first printing - Editor
For Changes in ads during the year, please send \$2.00 per line.

| | | |
|--|---|---|
| <p>A.W. PARKER Heisey & Pattern Glass Shows or Appointment Magalia, CA 95954 PH: (916) 873-2326</p> | <p>GLASS WITH CLASS Lenore A Shelley, GGHCC 1336 Lincoln Avenue San Jose, CA 95125 PH: (408) 286-8098</p> | <p>COSHOCTON ANTIQUE CENTER A Community of Dealers 309 South 4th Street Coshocton, OH 43812 (614) 622-3223 Open Daily 10-6 (closed on Mondays, Jan-Mar)</p> |
| <p>ALL HEISEY AUCTION Consignments Welcome Apple Tree Auction Center 1616 W. Church, Newark, OH 43055 PH: (614) 344-9449</p> | <p>GREEN ACRES FARMS Antiques, Crystal Glass & Collectibles 2678 Hazelton-Etna Rd., SW (S.R. 310-N) Pataskala, OH 43062 Sat. or Sun. PM or call (614) 927-1882</p> | <p>"HEISEY" PRICE COMPARISON GUIDE \$13.00 B. Whaley 614-927-1557 300 International Dr. Pataskala, Ohio 43062</p> |
| <p>ALFA I CARRIAGE HOUSE ANTIQUES Featuring Depression & Elegant Glassware Al & Faye Maness Rt. 1 Box 552, Ashland, VA 23005 PH: (804) 798-1825</p> | <p>H & R DIAMOND H Helen & Robert Rarey 1450 White Ash Dr. Columbus, OH 43204 PH: (614) 279-0390 after 5:30</p> | <p>PARRETT'S ANTIQUES Heisey 4994 Mapledale Rd. OR 1215 Greenwood Ave. Jackson, Mich. 49201 PH: (517) 784-7319 OR (517) 783-3289</p> |
| <p>ANTIQUES - THE SHULTZES 206-208 East Main St. Newmanstown, PA 17073 15 Miles West of Reading, PA PH: (215) 589-2819</p> | <p>"HAPPINESS IS" - THE STULTZS 3106 Warren Court, Glen Allen, VA 23060 Shows and Mail Order PH: (804) 672-8102 GLASS CIRCA 1890-1960</p> | <p>PATTON HOUSE Rocky's Mail, I-81 & US 11 Weyer's Cave, VA 24486 PH: (703) 967-1181 The Antique Gallery, Richmond, VA</p> |
| <p>C & J ANTIQUES Cole & Jean Miesner Box 45, 72 Whig St. Newark Valley, NY 13811 PH: (607) 642-9905</p> | <p>HARRALSON'S HOBBIES Heisey - Rose O'Neill Items - Doll Repair 1426 W. Highland, Springfield, MO 65807 PH: (417) 883-2449 Cliff & Helen Harralson</p> | <p>EAGLES REST ANTIQUES Carl and Mary A. Evans Heisey - China - Pottery, etc. Shows or Appointment PH: (614) 522-2035</p> |
| <p>GLASS RESTORATION LeRoy Carter, Jr. 125 Maple Ave. Utica, Ohio 43080 Phone 614-892-2775</p> | <p>HELEN & JIM KENNON Heisey, Cambridge, Fostoria, Duncan, Imperial, Fenton, Tiffin P.O. Box 114 Brookville, OH 45309 PH: (513) 833-5406 SHOWS ONLY</p> | <p>R & L ANTIQUES-SAN FRANCISCO Members of the Golden Gate Heisey Club 3690 Bodega Ave. Petaluma, CA 94952 PH: Petaluma (707) 762-2494 PH: San Francisco (415) 621-6693</p> |
| <p>CHARLES & MILDRED FISHER Heisey, Degenhart, Imperial, Antiques, Collectibles, General Line 991 Idlewilde, Newark, OH 43055 PH: (614) 522-5398</p> | <p>JJ MC KEE ANTIQUES Pottery - Glassware - Collectibles 222 B West 75th St. Kansas City, MO 64114 Wed.-Sun. 10-5 PH: (816) 361-8719</p> | <p>THE WOODEN SHOE Antiques & Collectibles Jim & Sheri VanEs by Appt. 810 Elden, Herndon, VA 22070 PH: (703) 435-9045</p> |
| <p>CRYSTAL LADY Joann Hagerty Specializing in elegant depression glassware 1819 Vinton Street, Omaha, NE 68108 Shop Ph. (402) 341-0643 or Home Ph. (402) 391-6730</p> | <p>J. & R. COLLECTIBLES Shows, SASE, Mail Order list June & Ray Lukasko P.O. Box 1030, Newark, OH 43055 PH: (614) 344-9719</p> | <p>SCHWAN'S ANTIQUES SHOWS & MAILORDER 77 Lagos del Norte Ft. Pierce, FL 34951 PH: (407) 461-5940</p> |
| <p>DIAMOND H PLUS Mail Orders & Shows George & Eileen Schamel 6625 Gilardi Rd., Boonsboro, MD 21713 PH: (301) 432-6285</p> | <p>MOSTLY HEISEY Rhoda Curley 16 Clayton PL, Albany, NY 12209 Shop and Mail Order PH: (518) 482-6272</p> | <p>SHOW AND TELL ANTIQUES Art, Cut, Heisey and Pattern Glass 1525 Morrow Ave., Waco, TX 76707 Tues-Sat 10:30-4:30 PH: (817) 752-5372 Also: Mail Order and Shows Member NADA</p> |
| <p>ETTELMAN'S DISCONTINUED CHINA & CRYSTAL HEISEY a SPECIALTY P.O. Box 6491-HN Corpus Christi, TX 78411 PH: (512) 888-8391 Include SASE</p> | <p>MOUND BUILDERS ANTIQUES Heisey & Animals, General Antiques Irene Rauck 1138 Moundview, Newark, OH 43055 PH: (614) 344-6043</p> | <p>HEISEY PUBLICATIONS Box 102, Plymouth, Ohio 44885 All Vogel Heisey Books I, II, III, IV And Quarterly Newscasters available</p> |
| <p>FOREVER HEISEY Jan & Norm Thran Mail Order, Shows, Appraisal Service 1663 Londondale Pkwy., Newark, OH 43055 PH: (614) 344-5955</p> | <p>THE MUTED SWAN ANTIQUES 5486 Peachtree Rd., Chamblee, GA 30341 Heart of Chamblee Antique Row Specializing in Heisey & Cambridge Bill & Pat Miller PH: (404) 451-7620</p> | <p>WILLEY'S ANTIQUES & MUSEUM Specializing in Heisey 11110 Cannon Rd., Frazeyburg, OH 43822 16 miles east of Newark, OH PH: (614) 828-2557</p> |
| <p>GERT'S GLASS Heisey & Duncan Gertrude & Russell Swetnam 1926 Saratoga Dr., Adelphi, MD 20783 PH: (301) 434-5113</p> | <p>GLASS 'N' GLASS Virginia & Odell Johnson 6909 10th Ave. West Bradenton, FL 34209 PH: (813) 792-0604</p> | <p>JAMES S. HARRIS ANTIQUES/APPRISALS Box 672 Richmond, KY 40475-0672 PH:(606) 623-9100 Buying and Selling by Mail</p> |
| <p>GLASS 'N' GLASS Virginia & Odell Johnson 6909 10th Ave. West Bradenton, FL 34209 PH: (813) 792-0604</p> | <p>NANCY'S ANTIQUES Heisey, Cambridge, Fostoria, Fenton Mail Order 906 44th St. NW, Canton, OH 44709 216-492-2595. Shop Union Station Antiques 12622 Cleveland Ave., Uniontown, OH Daily</p> | <p>TALL OAKS ANTIQUES 565 N. Nichols St., Lowell, IN 46356 Elegant & Dep Glass Specializing in Heisey. Shows - Mail Order - Shop - PH 219-696-0147 Mike & Barb Rosenberger</p> |

CONVENTION DATES FOR 1990 ARE JUNE 14-15-16-17

Make your reservations now as there are only 110 rooms and they go fast; most are gone by March 1st.

BEST WESTERN INN RESERVATION REQUEST

NAME _____
 ADDRESS _____
 CITY _____ STATE _____ ZIP _____

| | |
|--------------|--|
| PHONE _____ | All rooms have two double beds. |
| ARRIVE _____ | Double room requested (1 person) \$41.00 |
| DEPART _____ | Double room requested (2 people) 46.00 |
| | King or Queen room requested (1) 44.00 |
| | King or Queen room requested (2) 49.00 |
| | Rollaway bed 6.00 |

Please make your reservations by clipping the attached form and mail to:

Robert McClain
 336 Meadowbrook
 Newark, Ohio 43055
 PH: 614-366-7087

EACH RESERVATION MUST BE GUARANTEED WITH A CREDIT CARD OR CHECK.

14TH ANNUAL SOUVENIR OSCAR FORM

PLEASE READ VERY CAREFULLY BEFORE FILLING OUT

THE OSCARS ARE FENTON'S "ROSALINE", AN UNUSUAL COMBINATION OF PINK AND NEAR-WHITE. THERE IS GOLD IN THE BATCH AND WHEN THE ANIMALS ARE REHEATED IN THE GLORY HOLE THEY TURN PINK IN A RANDOM MANNER AND WILL BE BEAUTIFUL. THEY WILL BE MARKED HCA "90 AND FENTON.

THEY WILL BE OFFERED TO MEMBERS ONLY FOR \$24 PRIOR TO CONVENTION. IF ANY ARE LEFT BY JUNE 14, THEY WILL BE OFFERED TO THE GENERAL PUBLIC FOR \$27 EACH.

YOU MAY ORDER ONE PER MEMBER. THIS MEANS ANY MEMBER WHO HAS A MEMBERSHIP CARD REGARDLESS OF THE CLASS OF MEMBERSHIP. PLEASE LIST ALL NAMES AS THEY WILL BE CHECKED. EVERYONE LIVING IN OHIO ORDERING FOR PICK-UP IN OHIO, MUST PAY \$1.44 SALES TAX PER OSCAR. SHIPPING CHARGES WILL BE \$2.00. THE OSCARS SHOULD REACH US BY EARLY FEBRUARY AND WILL BE SHIPPED AS SOON AS THEY ARE RECEIVED.

DO NOT SEND DUES, BOOK ORDERS, ETC. WITH YOUR OSCAR ORDER

PLEASE KEEP THIS PART FOR A REFERENCE AND CLIP AND MAIL THE FORM BELOW THE LINE. BE SURE YOUR DUES ARE CURRENTLY PAID. THIS IS THE 14TH OF A SERIES OF SOUVENIR OSCAR.

MAKE CHECK PAYABLE TO HCA, INC.

NUMBER OF OSCARS AT \$24 EACH \$ _____
 SALES TAX \$1.44 EACH _____
 POSTAGE \$2.00 EACH _____
 TOTAL SENT WITH ORDER \$ _____
 NO PHONE ORDERS PLEASE

ONLY ONE PER MEMBER
 ALL OHIO RESIDENTS & PICK-UPS IN NEWARK
 CHECK ONE: _____ PLEASE MAIL MY OSCAR TO ME
 _____ PLEASE HOLD MY OSCAR AT THE
 MUSEUM AND I WILL PICK IT UP
 DURING OR AFTER CONVENTION.

NAME(S) _____
 ADDRESS: _____ CITY _____ STATE _____ ZIP _____

MASTERCARD
 VISA
 EXPIRATION DATE REQUIRED: MO ___ YR ___

MAIL TO: HCA OSCAR SALES, P.O. BOX 4367,
 Newark, Ohio 43055

sculptured... modern... inexpensive

Waverly

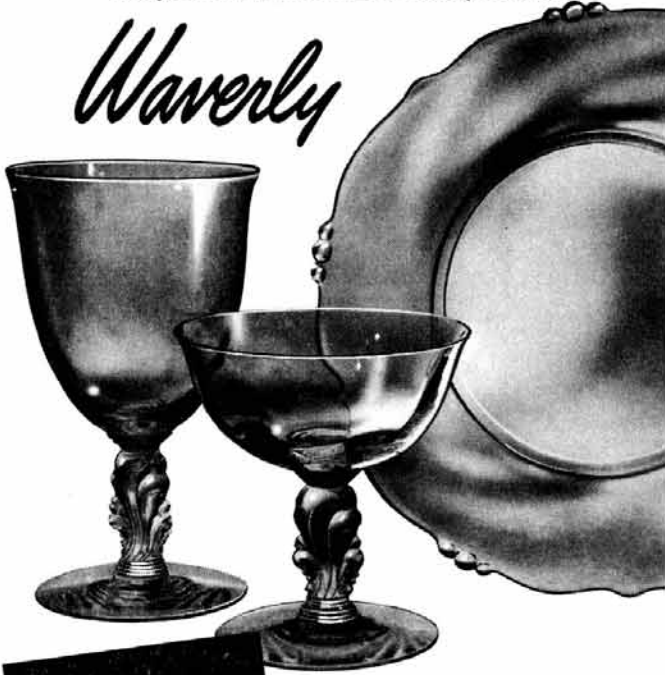

Choose the functional beauty of WAVERLY, available in hand-blown stemware and matching table accessories. Perfect for giving, too... and moderately priced. For free folder, write A. H. Heisey & Co., Dept. A-5, Newark, Ohio.

THE FINEST IN GLASSWARE, MADE IN AMERICA BY HAND

1589 Rye Bottle

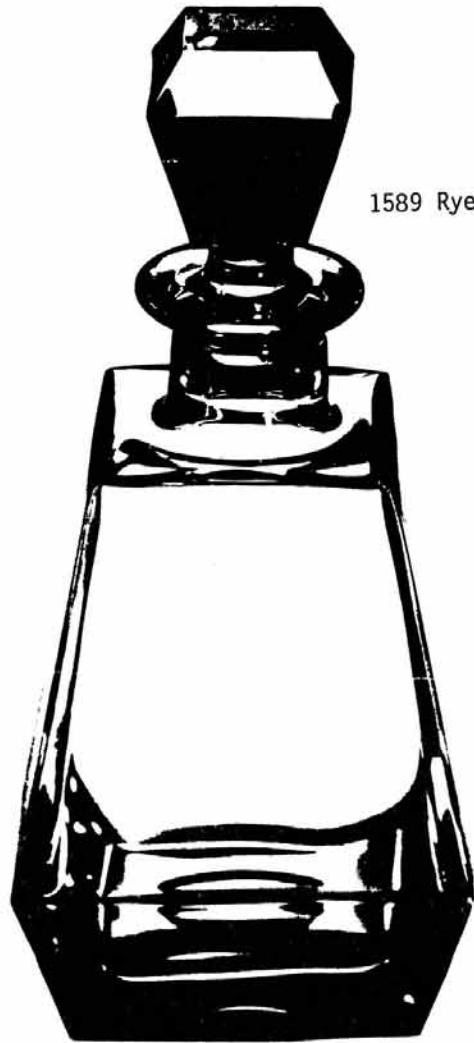

National Heisey Glass Museum

Eight rooms and complete lower level displaying the beautiful hand made glass produced in Newark by the A.H. Heisey and Co. from 1896-1957.



Corner of West Church & North Sixth Streets
Newark, Ohio 43055

Phone: (614) 345-2932

Hours: Daily 1pm-4pm Closed Holidays

OHIO
the heart of it all! SM

Membership Renewal Notice

The date above your name and address is your renewal date. This is your last issue of the Heisey News if it reads 1-10-90

PLEASE DISREGARD THIS NOTICE IF YOU HAVE RECENTLY PAID YOUR DUES.

POSTMASTER SEND FORM 3579 TO:



SECOND CLASS