

HEISEY NEWS

The Official Publication of Heisey Collectors of America, Inc.

Volume XXXVIII No. 9

September 2009

ISSN 0731-8014

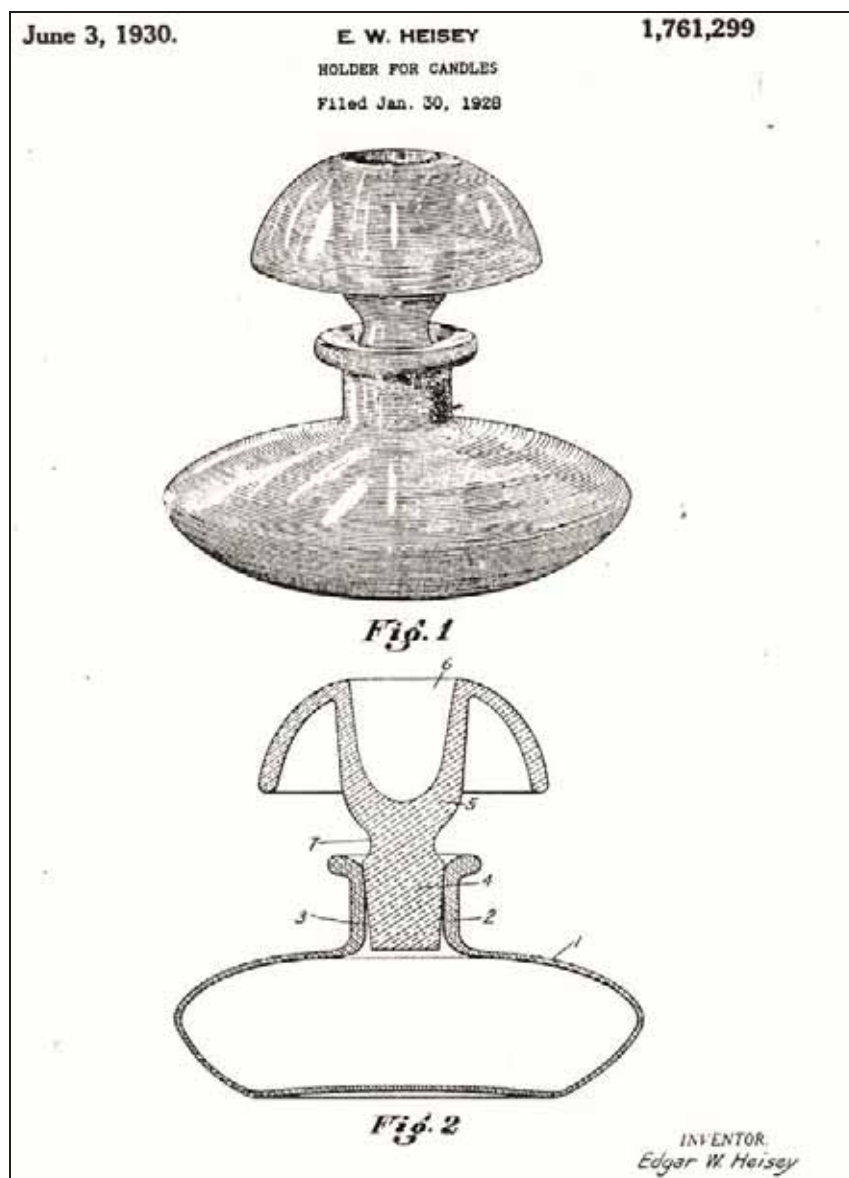

Patent 1,761,299 – 520 Innovation Candle Lamp

Read Part Seven of the Story of A. H. Heisey & Company Utility Patents on Page 5

HEISEY NEWS

Heisey Collectors of America, Inc.

169 West Church Street

Newark, Ohio 43055

Phone 740-345-2932 Fax 740-345-9638

Web Site: www.heiseyMuseum.org

All Rights Reserved 2009

ISSN 0731-8014

Staff and Phone Extensions

Curator, Walter Ludwig, curator@heiseyMuseum.org, Ext. 4

Clerks, Justin Church, Ashley Selby, Micki Wareham

membership@heiseyMuseum.org, Ext. 1

Gift Shop, Ext. 5

HCA Board of Directors:

President, Sue Kilgore – Kalamazoo, MI, 269-345-3990 –

hcapresident@heiseyMuseum.org

Vice-President, Karen Taylo – New Bern, NC, 252-637-9985

Secretary, Charlene Bowman – Clarksville, OH, 937-289-2114

Treasurer, Sharon Orienter – Rochester, NY, 585-288-8076

Member-at-Large, Dave Spahr - Xenia, OH, 937-372-7166

Bryan Baker - Fairfax Station, VA, 703-250-6117

Sid Edwards – Tallassee, AL, 334-283-4663

Tom Files – Kansas City, MO, 816-468-7087

Amy Jo Jones - Beavercreek, OH, 937-426-1567

Bob Kreimer – Ocala, FL, 352-873-8306

Robert Loch – Custer, WA, 360-366-3166

Jack Metcalf – Utica, OH, 740-892-2664

HEISEY NEWS is published and printed monthly, by Heisey Collectors of America, Inc. (HCA). Periodical postage paid at Newark. Subscription is limited to HCA members. First class mailing is available for an extra \$20.00, due with payment of membership. If you are having difficulty receiving your Newsletter, please contact the HCA Administrative Office Monday through Friday 8:30 a.m. - 4:30 p.m.

The opinions expressed in articles in HEISEY NEWS are those of the authors and not necessarily those of the organization. The Editorial Staff reserves the right to edit, with or without the consent of the author or to refuse any material submitted for publication.

Back Issues

Back Issues available from files are \$3.00 per issue plus shipping and handling

Advertising

Ads may be mailed to: HCA Advertising, 169 W. Church St., Newark, OH 43055; faxed to (740) 345-9638; or e-mailed to curator@HeiseyMuseum.org. Whenever possible, please e-mail your ad. Always include your MasterCard or Visa number and expiration date. When mailed or faxed, ads should be typed or printed on white paper with dark ink. Camera ready ads are accepted, but must follow line specifications outlined at the beginning of the advertising section. Ads containing reproductions will not knowingly be accepted unless clearly stated (e.g. Heisey by Imperial, etc.). HEISEY NEWS accepts no further liability. In the event of a typographical error, the incorrect portion of the ad will be run in the following issue, but HEISEY NEWS assumes no further liability. See advertising section for rates and deadlines.

Museum

Heisey Collectors of America, Inc., a non-profit corporation (tax-exempt status), owns and operates The National Heisey Glass Museum in Veterans Park, 6th and Church Streets, Newark, Ohio. Open year round, Tuesday through Saturday 10:00 a.m. – 4:00 p.m., Sunday 1:00 – 4:00 p.m. (except Jan. and Feb.), closed holidays. Other hours by appointment. Members admitted free.

Identification

HCA will attempt to identify unknown glass items. Send a color photograph, measurements, and a self-addressed, stamped envelope to the attention of the Curator. Other arrangements should be made in advance with the Museum staff. Please keep in mind that the Museum cannot appraise items. Identification is free to members, non-members \$5.00 per item.

Membership

To join Heisey Collectors of America or to renew your membership, contact the HCA Administrative Office Monday through Friday 8:00 a.m. - 4:30 p.m. Eastern Time. Associate dues are \$30.00 plus \$5.00 for each additional household member. Voting members pay an additional one-time fee of \$25.00. Please consider supporting the Endowment Fund by joining at one of the levels listed on the back page.

Museum Gift Shop

There is always someone in the Gift Shop during the Museum's hours of operation to help answer questions or take orders. When ordering by phone, please have a credit card ready. When ordering by mail, please be sure to include appropriate charges such as shipping and sales tax. Please note that the HCA member discount does not apply to original Heisey or special project items.

Shipping and Receiving

Delivery is made much easier when we have a complete street address, not a PO Box. We prefer to use UPS. If you have not received a package, please call the Administrative Office to confirm it was sent. We will assist you in tracing it. If your package arrives damaged, please contact your local UPS representative. We insure everything.

Donations and Loans to the Museum

If you would like to make a donation to the Museum or have questions regarding items on loan, contact the Curator. HCA reserves the right to accept or refuse items based on current holdings.

HEISEY CALENDAR OF EVENTS

2009

Percy and Vivian Moore Memorial Weekend	October 2-3
2009 Fifth Heisey Select Auction	October 3
December Holiday Open House	December 5

Table of Contents

Utility Patents Associated with A.H. Heisey & Company (Part 7), Walter Ludwig	FC & 5-9
Heisey Calendar of Events	2
Message from the President, Sue Kilgore	3
Curator's Report, Walter Ludwig	4
HCA Welcomes New Members for July 2009	4
466 Panel and Double Pleat, Joe Lokay	9
342 Paneled Colonial, Joe Lokay	10-11
Percy & Vivian Moore Weekend Flea Market, Michael Maher	11
2009 Select Auction Preview, Walter Ludwig	12
2009 Heisey Select Auction Catalog	13-16
2009 Heisey Select Auction Absentee Bid Form	17
2009 Select Auction News, Dave Spahr	18
Absentee Bid Instructions, Dave Spahr	18-19
Terms and Conditions of Sale	19
Percy and Vivian Moore Annual Memorial Weekend & Dinner	20
Percy and Vivian Moore Annual Memorial Weekend & Dinner - Registration Form	21
Heisey Glass Museum Playing Cards, Order Form (Green Deck)	22
Study Club Directory	23
Club Notes	24-26
Advertising Guidelines	26
Classified Ads	26
Real Heisey in the Gift Shop	26
Dealer Directory	27
Museum Volunteers for July 2009	BC

MESSAGE FROM THE PRESIDENT

Sue Kilgore

Dear HCA Membership:

Where has our summer gone? It is finally warming up in Michigan and now it is September. We, personally, have had a very busy summer, filled with family reunions, trips to the beach, and lots of weeding in the gardens. One of the best things about summer is, of course, the Heisey Convention in Newark. We look forward to it every year and look back on all the wonderful Conventions in years past with fond memories.

One thing I keep hearing about, from dealers and friends alike, is how it "used to be" in past years.....the Granville Show, the "cookout" on the lawn before the opening of the "big show," the speakers at the banquet. Although we loved these things at the time, and even more now because of our memories, we should keep in mind the main reason we all come to Newark in June. Our love of Heisey glass, our Museum, and the wonderful friends we have made over the years through this experience. When we first started coming to our Convention (too many years ago to count), we would use it as a vacation, to get away and to maybe find "a sleeper" before someone else did. We were not concerned with the functions or how they came about, making friends, or even learning anything. We just wanted to be entertained and see beautiful glass. MY HOW THINGS HAVE CHANGED!!! It is my hope that more of the membership gets involved in the purpose of HCA and the dedication of its Board of Directors and volunteers, both local and global.

I often wonder what we would do with our time IF we didn't devote it to Heisey.....the hunt, the find, the washing, the cataloging, the bragging, the using and the loving. I guess we will never know because we have the HEISEY LOVING DISEASE.

One thing that comes along with [one of my most dreaded words] "fall" is the Percy and Vivian Moore Weekend. This year it is being hosted by your Board of Directors in Newark and in conjunction with the 4th Annual Select Auction. You will find more details on other pages of your Newsletter. Please remember that we need all of you to come to Newark and join us for this great fund-raising event for HCA. The dinner dance will be fun, the flea market has that piece you have been looking for at a "deal" of a price and if not the select auction will.

Speaking of auctions and the glass that you send, the Board of Directors, and especially Dave Spahr, hopes that you understand the process of "donating" glass to HCA for us to auction. I would like to try to make it simpler to understand. Webster's dictionary defines DONATE as: **"to make a gift of; especially: to contribute to a public or charitable cause"**. So, when we have an auction, please DONATE, or give, us glass to sell for the betterment of HCA and then consign to us glass to sell for you. If everyone who sent in glass to be sold at our auctions, would send half as a donation and half as a consignment then think of what wonderful things could happen. You would feel good about having helped HCA and we would feel good, too. So, "donate" equals a deduction and "consigned" does not. We hope to see a lot more "donated" items for the next auction and we appreciate your support and generosity.

We sadly note the passing of one of our members, Marian Heron of Rochester, NY. Her sons, Jonathan and Scott, asked that contributions be made to HCA in her memory toward the naming of a piece of Heisey. We greatly appreciate their thoughtfulness and her long time membership to HCA.

Until next time, Heisey lovers, happy hunting and see you in Newark in October

Sue Kilgore ♦

CURATOR'S REPORT

Walter Ludwig

It is hard to believe that summer is almost over. Here in central Ohio we could not have had a more pleasant summer. The temperatures stayed in that comfortable zone for most of the time. We had just enough rain to make everything green without it being a nuisance. If this be global warming, then I am all for it.

But now the sure signs of the end of summer are beginning to appear. The kids have headed back to school. A few chillier nights have slipped in. And most important of all, we are getting ready for the Percy and Vivian Moore Weekend which this year is being held here in Newark on October 2-3. The announcement of events as well as the registration form can be found in this issue of the Newsletter on pages 20 and 21. And one of the highlights of that weekend will be our Fourth Annual Select Auction held here at the Museum on October 3. You will find the auction catalog in this issue as well as a preview article and all the information that you need to bid either in person (I hope you will be able to make it) or by mail bid. I know that the Board has planned some very special events that you all will enjoy.

Last month we published the gifts to the Museum for the first half of 2009. I am sorry to say that a few very special gifts did not make it into that listing and I want to acknowledge them now.

Endowment Fund Donations

Central Illinois Heisey Collectors Club, \$100

Heisey Club of California, \$50 in memory of Eleanor Brice

Heisey Club of California, \$50 in memory of James Van Winkle, Jr.

Northwoods Heisey Club of Minnesota, \$500

Operating Fund Donation

Northwoods Heisey Club of Minnesota, \$500

We have had a lot of visitors here at the Museum this summer. Did you know that visitors from outside the United States especially enjoy visiting our Museum because of all of the beautiful things we have on display here? We recently have had visitors from Brazil, Columbia, Japan, the Ukraine, and many from Canada. It is always a pleasure to show these special visitors around our Museum.

We have also had many tour groups through the Museum. Some are church groups or from senior citizen facilities. We are always happy to see groups of red hats come through the Museum in their colorful outfits. And we do get a few from tour companies but the cost of fuel has meant that fewer of these groups make it compared to past years. A depression glass club from Michigan will be paying us a visit in October. These groups are some of the most enthusiastic that we have come through the Museum. They always have so many questions and I really do enjoy when we have a group of people who already have an appreciation of the glass we all love so much.

It is time to start another round of cleaning the glass and the glass cases here in the Museum. Most of this work will be done on a Monday. Please let me know if you can volunteer some time to do this vital job to keep our Museum looking in top form.

I hope that the summer has afforded you the opportunity to pick up a lot of lovely pieces of Heisey in your travels. It is time to get out again before those outdoor flea markets close for the season. Give it one more look and see what you can find. Remember, Heisey will not find you; you have to go and seek it out. ♦

**HCA WELCOMES
NEW MEMBERS
FOR
July 2009**

Sharon Colone, CA

UTILITY PATENTS ASSOCIATED WITH A.H. HEISEY & COMPANY (PART 7)

Walter Ludwig

I want to thank all of the reader's of this Newsletter for staying with me as we have gone through the Heisey utility patents. Up to this point most of the patents dealt with some of the processes that go on inside the glass factory. We have had a lot of patents that dealt solely with the finishing process that Heisey put the glass through after it was molded. Some of these patents were rather dry and hard to really understand. But they have their place in the story of A.H. Heisey & Company. The patents could also be appreciated as pieces of industrial art that tell a different story of the company than the glass that they produced.

Well, now is the time for some of the most interesting patents that we will cover in this series. These are patents for true innovative pieces of glass that the company produced. The patents that will be covered in this article were issued from June of 1930 up to May of 1934.

The first one we will investigate is patent 1,761,299 issued on June 3, 1930 to E. W. Heisey for a "holder for candles." You can see the design drawing that accompanied this patent on the front cover of this Newsletter. I am sure that many of you recognized the 520 Innovation candle lamp.

The actual patent lists the inventor as "Edgar W. Heisey, of Newark, Ohio, assignor to A. H. Heisey & Company of Newark, Ohio, a partnership." We are used to referring to the inventor as E. Wilson Heisey, son of A. H. Heisey and the second president of the company. Just as many of the earlier patents had A. H. Heisey's name on them, we now find E. Wilson's name on this patent. Again, we do not know how much involvement that E. Wilson had in developing this fascinating piece because it would have been standard practice at this time

to have the patent in the name of an officer of the company for anything that was developed by an employee. The application for this invention was filed on January 30, 1928.

The patent reads, "My invention relates to a holder for candles. It has to do, particularly, with a novel combination of a receptacle and a closure therefore, with the closure specifically designed to be both effective as a closure and to constitute a support for a candle.

"One of the features of my invention consists in the fact that it comprises a receptacle which may be filled or partially filled with colored material of any type. Another feature of my invention consists in the fact that a fluid-tight stopper is provided. Another feature of my invention resides in the fact that a stopper is provided with a socket for the reception of a candle and with an apron to protect the receptacle from dropping candle grease. My entire structure is preferably designed to simulate, in a general way, a common type of candle holder."

The 520 Innovation candle lamp appears in catalog 109 which is usually dated 1929 but does not appear in the 1933 catalog. The lamp is not an uncommon piece; however, many of them that are found have been stained because of the water that was often put into the bottom receptacle. The Felt and O'Grady *Heisey Candlesticks, Candelabra, and Lamps* reports it being made as late as 1940.

Our next patent is number 1,774,871 granted on September 2, 1930 to Ray C. Cobel, of Newark, Ohio, Assignor to A. H. Heisey and Company. The patent is for an "apparatus for making articles of glassware." The application was filed on April 17, 1928.

I am going to quote from the patent a little more extensively than I do on most so that you can understand the reason for this innovation. The patent reads, "My invention relates to ... making articles of glassware, such as dishes or the like, that are provided with suitable handles."

"Heretofore, it has been customary to make handled glassware, such as dishes or the like, by forming the article by any of the well-known methods, for instance pressing, and then attaching and shaping the handle by hand.

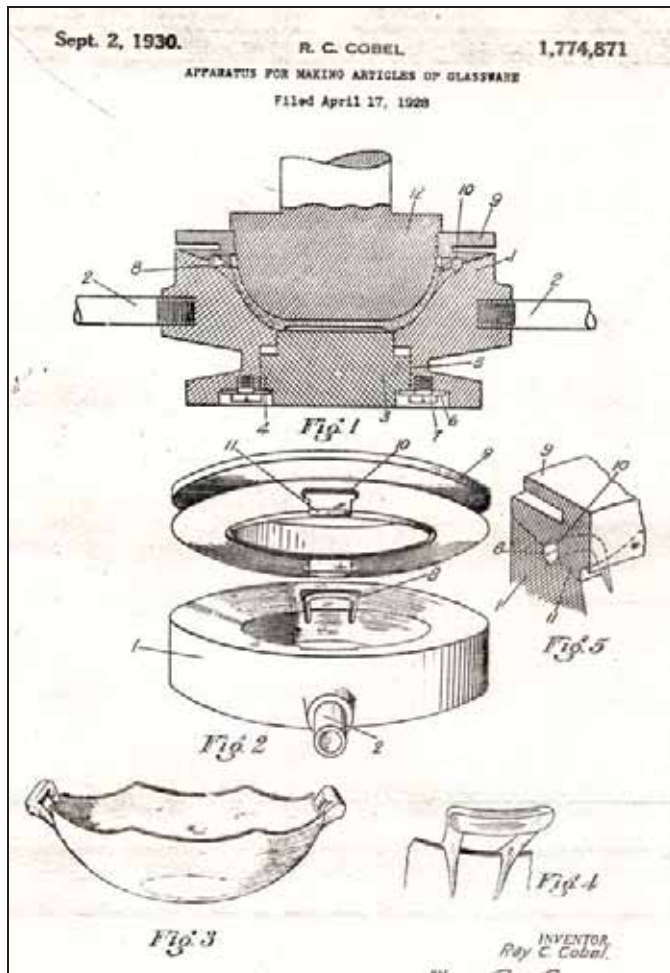

Patent 1,774,871 Showing Mold for 1229 Octagon Jelly

"The attachment of handles to glass articles by hand method is a slow, laborious and consequently, expensive operation, requiring workmen of a high degree of skill. In addition to this, such method has practically precluded the idea of making glassware having handles thereon of such shape and designs as to add materially to the ornamental effect of the ware.

"Making handled glassware, such as dishes or the like, by forming the body portion and then attaching and shaping the handles has had the added disadvantage which results from attaching two pieces of glass together when such pieces of

glass are at different temperatures. A perfect weld is seldom, if ever, formed between the pieces of glass under such conditions and, in glassware having handles thereon, this has increased the possibility of the handles breaking away from the body portion of the article.

"One object of my invention is to provide a method and apparatus for making glassware, such as dishes or the like, having handles thereon whereby the handles are formed integrally and simultaneously with the body of the article."

The drawings that accompany the patent display a mold and the final glass article made from the mold, in this case a 1229 Octagon jelly. The distinctive 1229 handles were formed within the mold using the process described in this patent. Given that separate parts of the mold were devoted solely to producing these handles, it is easy to see how these handles also appear on pieces of 1252 Twist rather than the traditional single point handles that are shown in the catalog drawings for the Twist pattern. Both styles of handles were made using this method.

Patent 1,784,232 was granted on December 9, 1930 to Edgar Wilson Heisey for an "Ice Receptacle." This patent was applied for on September 8, 1928. The patent reads, "My invention relates to ice receptacles. It has to do particularly with that type of article frequently referred to as an ice tub and used for the transportation of cracked ice, ice cubes, et cetera.

"One of the objects of my invention is to provide an ice receptacle which comprises a container portion formed of glass and a handle structure which is readily attachable to minimize the strains incident to the connection of the container and the handle structure.

"Another object of my invention is to produce a container structure of glass having lugs integrally formed thereon. These lugs are not only integrally formed but they are provided with specially shaped and reinforced apertures

designed for cooperation with a specially shaped and reinforced connecting bolt structure which forms a part of the handle structure of my device.

“More specifically, my invention comprises a container structure of glass having integral apertured lugs. These lugs preferably have their apertures formed on a taper and provided with a reinforcing annular lip at the bottom thereof. The handle structure preferably comprises a bowed member whose ends are pivotally connected to the L-shaped heads of bolts having tapered shanks which are adapted to be disposed with a wedging action in the apertures of the lugs.”

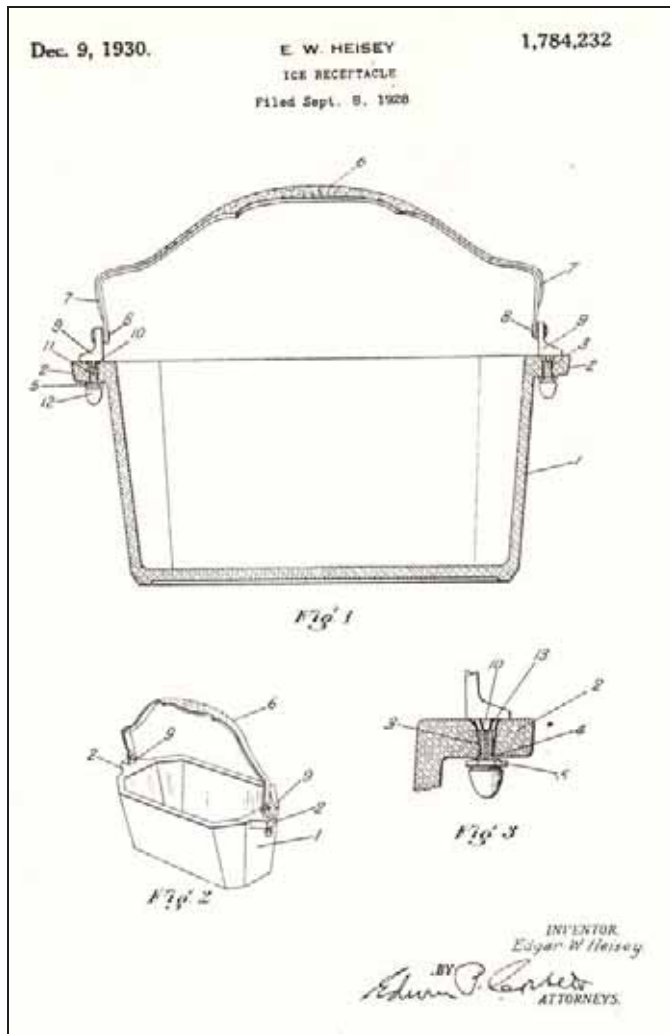

Patent 1,784,232 – 500 Octagon Ice Bucket

The design drawing shows the 500 Octagon ice bucket with its distinctive connectors for the handle. The patent was much more about the

connecting apparatus for the handle and bucket including the innovative lugs through which the connection was made. This same patent would covet the similarly designed connection on the 1252 Twist ice bucket.

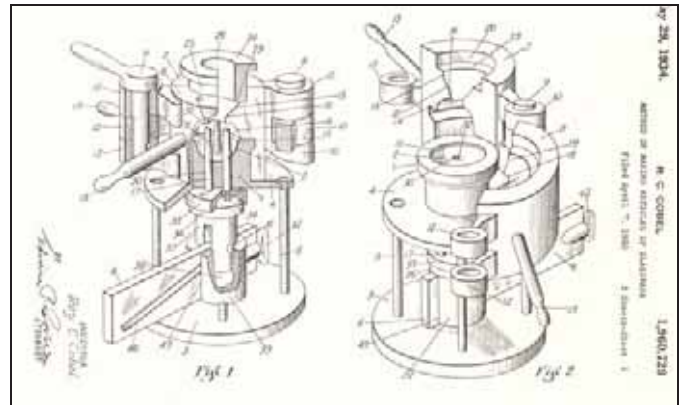

Patent 1,960,729 – Illustration 1

The final patent that we will look at this month is number 1,960,729 issued on May 29, 1934, to Ray C. Cobel for a “method of making articles of glassware.” This application was filed on April 7, 1930. The particular objects covered by this patent are flower blocks with the holes going all the way through the block. Heisey produced three different sized blocks with this process. The number 19 block is 4” (6 holes), the number 20 block is 5” (18 holes), and the number 21 block is 6” (19 holes). These blocks appear to have been made from 1930 to 1938 to be used with various sizes of floral bowls. Heisey also had a series of blocks (numbers 9, 10, and 11) in which the holes did not go all the way through. These were made starting in 1923 but even though production continued until 1938 like the other blocks, it must have been felt that a hole through block would be superior consequentially the newer ones were developed. As the patent explains it took a new process to be able to produce a satisfactory block with the holes going through.

The patent reads, “ One object of my invention is to provide a method of making glassware, such as flower blocks and the like having an apertured body portion, in such a way as to reduce the cost of making such blocks without sacrificing the quality of the blocks.

"Another object of my invention is to provide a method of making flower blocks or the like, whereby the openings therein will be entirely free from closed ends subsequent to the pressing operation, thus obviating the necessity for having a worker punch out the closed ends by hand.

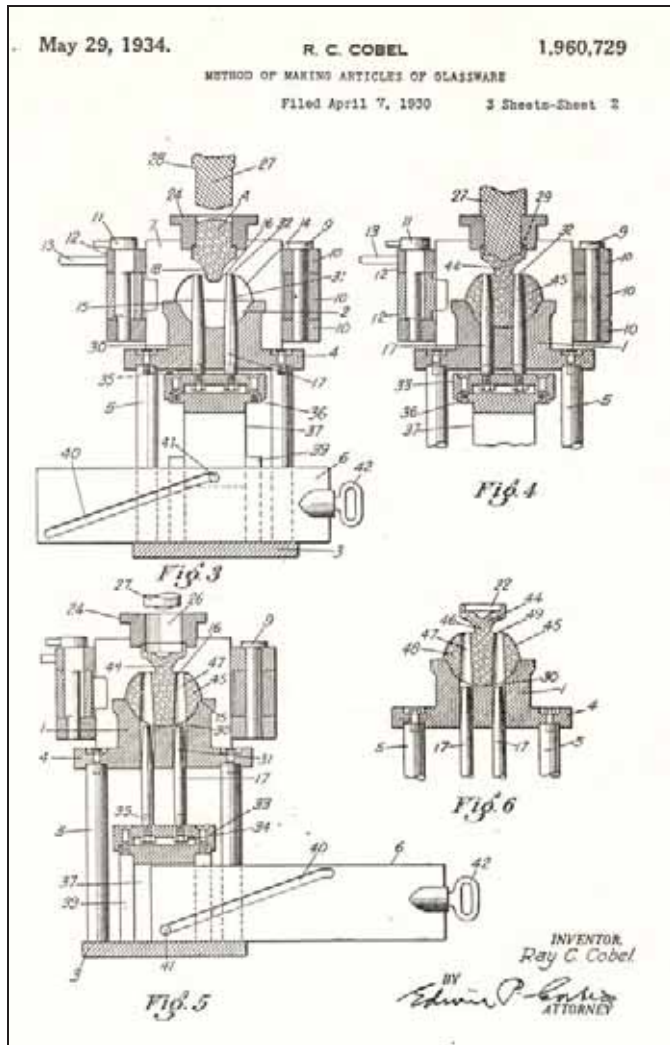

Patent 1,960,729 – Illustration 2

"Another object of my invention lies in the provision of a method for the manufacture of flower blocks, whereby the base of the finished article will be free from chips, cracks and other irregularities and, furthermore, will be smoothed and concave to present a surface of pleasing aspect to the eye.

"Still another object of my invention is to provide a flower block that will rest firmly on a support surface without danger of scratching or

marring the finish thereof, and furthermore, will not spin or rotate when placed thereon.

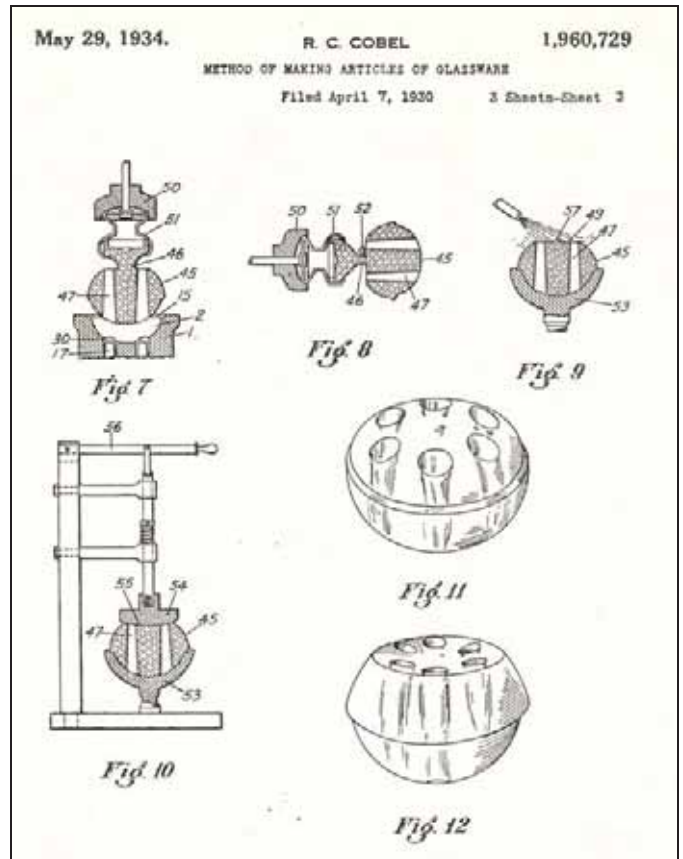

Patent 1,960,729 – Illustration 3

"My invention contemplates the provision of a method of manufacturing flower blocks and the like, wherein a charge of glass is pressed while in a plastic state in a mold having a plurality of pins disposed therein. These pins are movable into and out of the mold cavity independently of the plunger and, prior to the pressing operation, are adapted to be moved upwardly into the mold until their flattened heads are in firm contact with the flattened upper surface of the mold cavity. Thus, when the charge of glass is pressed in the mold it will be shaped by the contour of the mold cavity and will completely surround each of the pins, although the material will be precluded from entering between the flattened heads of the pin and the flattened upper surface of the mold cavity in view of the fact that these two surfaces lie in intimate contact during the formation of the article in the mold.

"After the molten material has become substantially fixed to allow the general contours of the openings in the article to retain their respective shapes, the pins are withdrawn therefrom by a suitable means forming a part of my invention, and the mold, which is preferably of the split section type is separated to allow ready access to the article. Furthermore, this mold is of the font type wherein the article that is formed therein will be equipped with a font by means of which the article may be readily lifted from the mold, and suitable means being employed to do this.

"At this time, the pressed article comprises a body portion having a plurality of open-ended apertures therethrough, and a substantially flattened base portion provided with a font formed integrally therewith. While the article is still in a semi-plastic state, it is rotated in contact with the proper tools for reducing the neck of the font, until the neck has been reduced sufficiently to permit ready severance of the font from the main body portion.

"The pressed article, thus far, retains the contour of the mold cavity of the split section mold. The next and final forming operation has to do with concaving and smoothing the base and removing the ragged fragments of material that might be left on the base subsequent to severance of the font. In order to accomplish this, I invert the blank in a former and the base thereof is reheated until the material becomes sufficiently plastic to allow a plunger to be forced downwardly thereon to concave and smooth this portion of the blank. This operation also tends to remove the mold marks from the base and the crown of the blank."

I quoted a lot of this patent because I felt it gave you the whole story on making one of these floral blocks. You can see that Heisey paid a lot of attention to the small details so that they produced a superior product.

Next month we will continue with additional utility patents that were awarded to A. H. Heisey & Company. ♦



466 Nappy

466 PANEL AND DOUBLE PLEAT

Joe Lokay

This is another short pattern consisting of nappies only. There were six nappies of diameters 4, 4 ½, 5, 7, 8, and 9 inches. Production life was 1914 to 1917 or about 4 years. The nappies were not listed separately as a pattern in the price list but were listed under Miscellaneous.

The design consists of plain panels with an arched top separated by two pleats. The panels carry into the flat bottom. The nappies are signed with the Diamond H. Vogel named the pattern Panel and Double Pleat.

In 1917, the Heisey Company assigned #466 to an 8 inch Fruit Basket. The life of the basket was 1917 to 1925.

Production

1. nappy, 4"
2. nappy, 4 ½"
3. nappy, 5"
4. nappy, 7"
5. nappy, 8"
6. nappy, 9"

References

1. Heisey Catalog #76 (1915), p.22
2. Heisey Price List #179 (1917), p.171
3. Heisey News, Aug. 1993, 466 Basket
4. Vogel Book 2, p.172 ♦



Top 341 ½ Puritan Table Set
 Bottom 341 Puritan Table Set
 From Vogel I, page 37

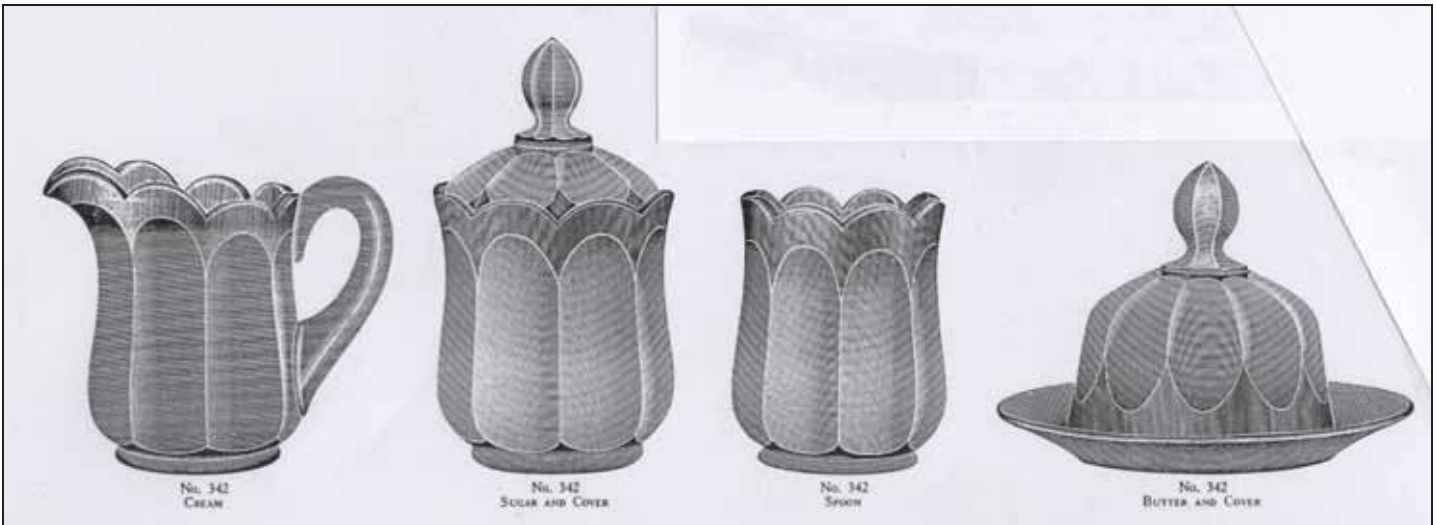

342 Paneled Colonial Table Set
 Catalog 100, page 148

342 paneled colonial

Joe Lokay

The 342 Panelled Colonial pattern is very small consisting of only a four piece table set. The design was colonial with panels, arches, and scallops on the uncovered pieces. It was named by early Heisey researcher Clarence Vogel.

The 342 pattern design is very close to the table sets for the 341 and 341 ½ Puritan patterns. The knobs on the two covers are the same. The cream, sugar and spoon are similar with 8 panels and a raised bottom. The covered butters have differences. The 342 has 10 panels and the 341 and 341 ½ covers have 8 panels. The butter bottoms for 341 and 341 ½ have scallop edge while the bottom for 342 is round. Perhaps with some fine measurements you might find some other differences.

The 342 pattern life is estimated from 1920 to 1926 or seven years. By the time this set was made the 341 set had long been discontinued. Somewhere in the 1920s, the concept of a 4 piece table set became obsolete. I would guess 342 was made in crystal only and was marked with the Diamond H. The covered butter you can identify. Good luck on the other 3 items – it is very possible that these pieces are identical to the 341 ½ table set pieces.

Production

1. cream
2. sugar and cover
3. butter and cover
4. spoon

References

1. Heisey Catalog #100 (1920), p.148
2. Heisey Price List #206 (1922), p.89
3. Heisey Price List #208 (1924), p.86
4. Heisey Price Catalog #102 (1924), p.140
5. Vogel Book 2 p.117, 342 table set
6. Vogel Book 1 p.37, 341 table set
7. Heisey Catalog #75, p.179 341 ½ ♦

PERCY & VIVIAN MOORE

WEEKEND FLEA MARKET

Michael Maher

Attention Heisey collectors and glassware dealers! Do you have extra glass that you would like to sell? Let your collections pay for themselves. Plan on attending a glass show/sale at the Museum grounds on Saturday October 3, from 10 a.m. until 1 p.m.

After the sale move into the Museum, to check out the preview for the 2009 Select Auction that will begin at 2 p.m. Several chances here to find that special piece that has eluded you all these years!

If you plan to set-up in the sale, set-up is free with no cost to you. We just hope to have a great turn out with a successful sale as in years past. Bring your own tables and table covers, glassware is not limited to Heisey, but this is a glass sale. No pottery, china, baskets etc. Bring as many tables as you want and as much glass as you want, the more you bring the more you can sell!

We hope that everyone coming back for the Percy & Vivian Moore weekend will bring some glass and a card table to sell some extras they have, or just a few items they decided to part with. Who knows you may pay for the items that you purchase in the auction or your entire trip for that matter!

I think it will be a great success for everyone, both the dealers who are selling and the customers shopping the sale, before the auction preview.

If you have any questions, please feel free to contact me at theflyingmaher@webtv.net or 740-763-4256. Thanks and we hope to see you on October 3 at the sale and 2009 Select Auction. ♦

2009 SELECT AUCTION PREVIEW

Walter Ludwig

On page 13 of this Newsletter, you will find the catalog for the 2009 Select Auction. Boy, do we have a treat in store for you with this auction. The auction has something for everyone's taste and pocketbook. There are little things, there are early pieces, pieces from most of the major patterns. There are animals, vases, and candlesticks galore. Give the catalog a good going over because there is bound to be something that will please you. Now, I am going to go over some of the highlights of the auction which means that I will spotlight some of the rarer pieces because my room is limited and I want to be sure that you do not miss these beauties.

Right off the bat we have a rarely seen tumbler that is bound to tickle the fancy of the tumbler collector, a 1460 Flame tumbler (Lot 2). A couple lots below are two Hexagon Stem colognes with 693 Cloister cut. What distinguished the two colognes is that the stoppers are different but both were stoppers that Heisey offered on this cognie but that changes the pattern number. Lot 9 is the 486 Hexagon Stem cognie and lot 9A is the 493 Hexagon Stem cognie. A beautiful 1201 Fandango cake server (Lot 24) and a 1185/109 Petticoat Dolphin compute in Flamingo (29) follow soon after.

As I said there are a lot of candlesticks and we divided them into three different sections of the auction. But we lead off with some amazing pieces. A 300 Old Williamsburg 3 light candelabrum (single), 20 ½" (37) and a pair of 301 Old Williamsburg short base candelabrum with Cobalt short bases (38) are true standouts. Later in the auction we have a pair of 28 Elizabeth candlesticks, 9" (75) and a pair of 27 Daisy candlesticks, 9", grey cut (80). Late in the auction there is a single 20 Sheffield, 9" (157) and a pair of 1405 Ipswich candle centerpieces with vases (158).

A stunning 22 ½" 300 ½ Peerless swung vase (39) precedes a complete set of 365 Recessed candy jars (41 – 46). Another lovely early piece is a 1280 Winged Scroll 10" dresser tray with excellent gold trim (56). There are several Heisey baskets but probably the standout among them is a 459 Round

Colonial, 7" with frosted panels that have been cut to clear (68). You do not see such a piece often.

In Moongleam there are a couple of great pieces including a 419 marked Sussex goblet with a Moongleam stem and foot (86) (you usually only see this with a Moongleam bowl). The other great piece in Moongleam is a 1420 Tulip vase (87). Later on in the auction there is another 1420 Tulip vase but this time in crystal with a great cutting (142).

A couple of nice etched pieces include dinner bells in both 509 Orchid (101) and in 515 Heisey Rose (106). There is also a really nice 1519 Waverly fan vase with 515 Heisey Rose (103).

Zircon/Limelight is well represented with a 1489 Saturn flared vase, 8 ½" (110), a 1506 Provincial footed candy box (111), a 4085 Saturn 4" ball vase (112), and a 4085 Kohinoor wine with a zircon bowl (113). In Dawn we have a 1951 Cabochon butter (128) and in Tangerine a 3397 Gascony wine (131).

We have one of the rarer pieces of 1503 Crystalite in the auction: a 9" lily vase (120) – truly magnificent. In 1540 Lariat there is a 10 basket with the side loops (144).

The auction has several rarer pieces with deep plate etches including a 4054 Coronation martini pitcher with 510 Tavern etch (136), a 2052 1 ½ oz bar with 474 Circus – Clowns etch (139), and two different 4163 Whaley beer mugs, one with 465 Golfer etch (137) and one with 459 Fisherman etch (138).

Lot 141 is a tall 1540 Aristocrat candy jar with lid beautifully cut with 794 Riviere cutting. We have a set of 4 1401 Empress 8" square plates in Cobalt (150) and 7" and 8" 2323 Navy plates (151, 152).

Lot 161 is a 1401 Empress 8" square plate in Alexandrite with a Krall cutting. This is one of a set of 12 plates that was broken up many years ago. Also in Alexandrite we have a 1001 Maezene marmalade (162). The final two items I will mention is a 464 Ribbon Candy 2 qt. jug (163) and a 517 tumble up set with the pitcher having a nice floral cutting (164).

This is an outstanding auction. I hope you can make it here to Newark. If not, please consider sending in an absentee bid. As you know, it is for a good cause.



2009 HEISEY SELECT AUCTION

National Heisey Glass Museum

Saturday, October 3, 2008

Preview 12:30 – 2:00 p.m.

Auction Begins at 2:00 p.m.

H = MARKED WITH DIAMOND H

♥D after the lot number indicates item donated to the Auction on the Museum's behalf; full amount will go to the Museum.

- 1 350 Pinwheel + Fan tumbler
- 2 1460 Flame tumbler H
- 3 337 Touraine wine H
- 4 433 Greek Key almond, ind H
- 5 325 Pillows toothpick H
- 6 50 Cabochon sign frosted
- 7 D 1540 Lariat cologne enamel décor
- 8 8 jug coaster H
- 9 D 486 Hexagon Stem cologne 693 Cloister cut H
- 9A D 493 Hexagon Stem cologne, 4 oz 693 Cloister cut H
- 10 D 363 syrup, 7 oz H
- 11 1567 Plantation marmalade (non-Heisey ladel) (2)
- 12 1425 Victorian cigarette box, 4" H
- 13 1405 Ipswich fingerbowl/underplate (4)
- 14 300 Peerless comport, 9" H
- 15 300 Peerless compote, 4 1/2" H
- 16 300 Peerless bitters (no tube)
- 17 D 1254 sherbet, conical center H
- 18 433 Greek Key sugar/cover, table set fair gold décor H
- 19 433 Greek Key butter/lid worn gold H
- 20 903 Jefferson goblet H
- 21 352 Flat Panel horseradish
- 22 341 Puritan salt & pepper, #2, AL tops, pr
- 23 D 411 Double Rib + Panel mustard/#10 paddle silver overlay H
- 24 1201 Fandango cake salver, 9 1/2"
- 25 D 1255 Pineapple + Fan rose bowl, 6"
- 26 1185 Yeoman floral bowl, 15" Flamingo
- 27 1403 Half Circle cream/sugar Flamingo H
- 28 1184 Yeoman cream/sugar/lid Flamingo H
- 29 1185/109 Petticoat Dolphin compote Flamingo
- 30 10 Oak Leaf coaster Flamingo (4)
- 31 1001 Caswell creamer/sugar sifter Flamingo
- 32 615 Taper cologne Flamingo H
- 33 3390 Carcassonne cordial Flamingo
- 34 3389 Duquesne goblet 913 Everglade (2)
- 35 5013 Shasta goblet unk cutting
- 36 4085 Kohinoor cordial unk cutting
- 37 300 Old Williamsburg candelabrum, 3 light, 20 1/2" paper label
- 38 301 Old Williamsburg candelabrum, 3 light, short base, pr Cobalt base

- 39 300 1/2 Peerless vase, 22 1/2" H
40 353 Medium Flat Panel vase, 15" H
41 465 Recessed Panel candy, 8 lb H
42 465 Recessed Panel candy, 5 lb H
43 465 Recessed Panel candy, 3 lb H
44 465 Recessed Panel candy, 1 lb H
45 465 Recessed Panel candy, 1/2 lb H
46 465 Recessed Panel candy, 1/4 lb H
47 353 Medium Flat Panel candy, 1 lb gold trim H
48 1183 Revere candy, 1/4 lb black/gold décor H
49 1401 Empress vase, df Sahara H
50 1401 Empress goblet Sahara H
51 1401 Empress cstks, df, pr Sahara H
52 1509 Empress jelly, 6" Sahara H
53 1401 Empress mustard/spoon Sahara H
54 1401 Empress ice bucket Sahara H
55 1280 Winged Scroll jug floral décor Custard
56 1280 Winged Scroll dresser tray, 10" Gold trim Custard
57 1200 Cut Block sugar, ind souvenir "Elk Creek, WI" Custard
58 1101 Stitch punch cup souvenir "Holman, Wis" Custard H
59 1295 Beaded Swag wine souvenir "Oxford, WI" Custard
60 1295 Beaded Swag goblet rose bud décor Custard
61 310 Ring Band jelly, ftd worn gold band Custard
62 310 Ring Band spooner poor gold Custard
63 1255 Pineapple + Fan vase, 10" (2)
64 1255 Pineapple + Fan vase, 8"
65 305 Punt + Diamond Pt vase, 8"
66 465 Recessed Panel basket, 8" floral cut/striated panels H
67 465 Recessed Panel basket, 8" H
68 459 Round Colonial basket, 7" frosted panels, cut to clear H
69 459 Round Colonial 8" floral cut H "
70 464 fruit basket Windsor-like cutting H
71 461 Banded Picket basket, 7" H
72 461 Banded Picket basket, 7" Flamingo H
73 25 Federal cstks, 8", pr
74 1 Georgian cstks, pr
75 28 Elizabeth cstks, 9", pr H
76 2 Old Williamsburg cstks, 9", pr
77 22 Windsor candlesticks, 7", pr H
78 21 Aristocrat cstks, 7", pr H
79 47 Regal candlesticks, pr
80 27 Daisy cstks, 9", pr grey cut
81 1404 Old Sandwich compote, 5 1/2" H
82 1447 Rococo compote, 7" H
83 1401 Empress plate, 10 1/2", rd Moongleam H (4)
84 D 367 Prism Band decanter Moongleam H
85 4217 Francis vase, 6" Moongleam
86 419 Sussex goblet Mglm st/ft H
87 1420 Tulip vase Moongleam H

- 88 4133 Thumbprint + Panel vase, straight, 9" H
- 89 451 Cross Line Flute vase. 5" H
- 90 358 Prison Stripe vase, 5" H
- 91 1401 Empress sandwich, ctr handled 450 Chintz
- 92 134 Trident 2 light cstk, pr 458 Olympiad
- 93 1495 Fern whipped cream/underplate/spoon 500 Belvedere etch
- 94 1469 Ridgeleigh ashtray, 6" adv "Piqua Paper Box Co."
- 95 1567 Plantation relish, rd, 4 pt 516 Plantation Ivy H
- 96 D 1255 Pineapple + Fan vase, 6" worn gold Emerald
- 97 1205 1/2 Fancy Loop bar, 2 oz good gold Emerald
- 98 1509 Queen Ann bowl, 8 1/2", crimped, 509 Orchid
- 99 1519 Waverly mint 509 Orchid H
- 100 3333 Old Glory goblet 509 Orchid H RARE - rim nick
- 101 5022 Graceful dinner bell 509 Orchid
- 102 5022 Graceful cordial 509 Orchid H
- 103 1519 Waverly vase, 7", fan 515 Heisey Rose
- 104 1519 Waverly plate, 8" 515 Heisey Rose (3)
- 105 5072 Rose Stem cordial 515 Heisey Rose H
- 106 D 5072 Rose Stem dinner bell 515 Heisey Rose
- 107 1519 Waverly candy/bow tie finial 515 Heisey Rose H
- 108 5012 Urn bud vase, 8" 515 Heisey Rose
- 109 1447 Rococo cheese, ftd 515 Heisey Rose
- 110 1489 Saturn vase, 8 1/2", flared Zircon H
- 111 1506 Provincial candy, ftd/lid Limelight H
- 112 4085 Saturn ball vase, 4" Zircon
- 113 4085 Kohinoor wine Zircon bowl
- 114 1469 Ridgeleigh candle vase Zircon H
- 115 1238 Beehive plate, 5" Zircon
- 116 1503 Crystolite oval tray, 13" H
- 117 1503 Crystolite puff box H
- 118 5003 Crystolite pitcher
- 119 5003 Crystolite ice tea (6)
- 120 1503 Crystolite vase, lily, 9" H
- 121 D 1557 Fighting Rooster Pink (Imperial)
- 122 D 1 Goose, wings down on the bust off Ruby (Mosser 99)
- 123 D Original Heisey Tool carry out holder
- 124 1557 Fighting Rooster
- 125 3 Goose, Wings Up
- 126 1541 Scottie
- 127 1550 Dolphin cstk
- 128 1951 Cabochon butter, stick Dawn H
- 129 D 1246 Acorn + Leaves plate, 6" Hawthorne
- 130 D 1184 Yeoman cream soup Hawthorne
- 131 3397 Gascony wine Tangerine bowl
- 132 1229 Octagon nut, ind Marigold H
- 133 150 Banded Flute tray, 10" H
- 134 4225 Cobel cocktail shaker, 1 qt/Rooster st
- 135 4225 Cobel cocktail shaker, 1 pt/Rooster st
- 136 4054 Coronation martini mixer 510 Tavern

- 137 4163 Whaley beer mug 465 Golfer
- 138 4163 Whaley mug, 16 oz 459 Fisherman H
- 139 2052 bar, 1 1/2 oz 474 Circus - Clowns
- 140 4052 National bar, 1 oz 467 Tally Ho
- 141 1430 Aristocrat candy/lid 794 Riviere H
- 142 1420 Tulip vase unk cutting H
- 143 1540 Lariat basket, 8"
- 144 1540 Lariat basket, 10" (side loops) H
- 145 1540 Lariat bonbon basket H
- 146 1540 Lariat relish, 3 pt, 10" H
- 147 1540 Lariat candleblock, pr
- 148 1540 Lariat vase, ftd, rd, crimped, 7"
- 149 1540 Lariat vase, 7", fan
- 150 1401 Empress plate, 8", sq Cobalt H (4)
- 151 2323 Navy plate, 8" Cobalt center
- 152 2323 Navy plate, 7" Cobalt center
- 153 3390 Carcassonne bar, ftd Cobalt bowl
- 154 22 Windsor cstk, 8" unk cutting H
- 155 1615 Flame cstks, pr H
- 156 1445 Grape Cluster cstk, one light H
- 157 20 Sheffield cstk, 9"
- 158 1405 Ipswich candle centerpieces/vase, pr H
- 159 1504 Regency candlesticks, 2 lt, pr
- 160 3380 Old Dominion goblet Alexandrite
- 161 1401 Empress plate, 8", sq Krall cut (1 of set of 12) Alexandrite H
- 162 1001 Maezene marmalade Alexandrite H
- 163 464 Ribbon Candy jug, 2 qt H
- 164 517 tumble up/tumbler unk cutting H
- 165 D 3408 Jamestown ice tea (4)
- 166 1295 Beaded Swag nappy, 4" gold.pink floral Opal (2)
- 167 7004 Wreath candy bottom/metal lid H
- 168 1445 Grape Cluster floral bowl, 12" satin handles H
- 169 1558 rolled edge floral bowl

◆



2009 Select Auction on View in Museum Multi-Purpose Room

2009 SELECT AUCTION NEWS

Dave Spahr

Hey!! Listen up!! Great news! The **Fifth Annual Select Auction**, which will be held in Newark, OH, at the Museum during our Percy and Vivian Moore weekend, will be here before we know it! The auction date will be here before you know it - **Saturday, October 3, 2009**. The **Preview will be from 12:30 p.m. to 2:00 p.m.** with the **auction beginning at 2:00 p.m.** Come to Newark and spend Friday night at the Percy and Vivian Moore Banquet and then Saturday for the auction. We will also be having a flea market! More about this later.

We have some great glass for your viewing and purchase! The glass is now on exhibit in the Multi-purpose Room of the Museum for you to see now! Stop in and see it!

Elsewhere in this Newsletter are the auction catalog, guidelines, and absentee bid forms. The catalog is for all of you to use - for those of you who can't make it but want to participate read our absentee bid instructions and use the absentee bid form. We should also have our catalog, instructions, and forms on our website, www.heiseymuseum.org. (We are currently in a state of transition with our website, so if you do not find the forms there, you can visit the temporary site at www.heiseymuseum.com and find them there). Walter Ludwig, our curator, has written an article highlighting a few pieces of the wonderful glass available to be auctioned off. Be sure and read it! Also, Auctioneer Gary Babcock has graciously agreed to again come and volunteer his services

I want to extend a special thanks to our 18 consignors who have made this, the fifth annual Select Auction, not our biggest but one of our finest. We have 170 lots of great glass of which 13 lots are donations. This is REALLY special for HCA since all the proceeds from the donations go 100% to help fund Museum operations.

As I promised – more on the flea market: **We will have a flea market** at the Museum along the edges of the parking lot **starting at 10:00 a.m. which will end promptly at 1:00 p.m.** We hope you will come, set up, and sell some of your finest! Hopefully, there will be some local dealers set up as well. There will be no charge for setting up and we are not limiting items to be sold to Heisey glass - we would like to see a great assortment of elegant glass for sale! If you have any specific questions, please contact Michael Maher at 740-763-4256.

See you all in Newark at the Auction and Flea Market. Happy Heisey Hunting! ♦

ABSENTEE BID INSTRUCTIONS

DAVE SPAHR

As absentee bidders, we will bid competitively for you at the HCA Select Auction, October 3, 2009. In case of duplicate bids, the earliest postmark wins. Bids must reflect the listing in the catalog as to lot number, pattern, description, and condition. The minimum absentee bid per lot is \$15.

You set the maximum amount you are willing to pay on each lot. If successful, the remainder will be refunded. Please use good judgment in arriving at your maximum bid figure. Remember, there are minimum limits to raises that the Auctioneer will accept (smaller items \$2.50, larger items \$5, \$10 or as much as \$25). Lots containing multiple items will be as one lot to the successful bidder. Normally, these are not split up; however, there may be some exceptions to this.

Please indicate on your bid the desired condition of the item on which you are bidding. We have endeavored to describe all items to the best of our ability and a bid on an item reflects your acceptance of the condition as listed. (As you know, if no flaws are noted, that means the glass is in generally good condition.) If you mark your bid "near mint only," we will use no discretion in your bid. If there is a variance on a lot not called in the catalog (such as unlisted damage or a difference in the number of items in a lot), we will not bid on that lot for you. Please use the form (or a copy) on page 17 of the

HEISEY NEWS to submit your bid. Absentee bids can be submitted by e-mail, fax, or postal service.

PAYMENT: Cash, check or money order payable to HCA Auction, and Visa/MasterCard accepted. A 5% buyer's premium will be added. Buyer's premium is deleted for cash, money order or approved check payments. You may send a separate check for each lot or you may send one check covering the maximum amount of all bids. Absentee Bidders must make their own shipping arrangements. See SHIPPING section below for further information.

In addition, if you would like to pay by check, PLEASE consider leaving the amount blank. Designate in the memo blank of your check an amount not to exceed the total amount of your bids. The Auction Manager will fill in the exact amount of your purchase, thus greatly cutting back on refunds. Surplus bid money will be refunded. Send in a self-addressed, stamped envelope to return your checks. HCA reserves the right to reject any bid.

SHIPPING: Buyers must make their own shipping arrangements. Glass is available to be picked up by your shipper on Tuesday, October 6, 2009, at the HCA Museum, 169 W. Church St., Newark, OH 43055. HCA is aware of the following area shipper: Pacmail: 740-522-2564. HCA is not responsible for any services provided by any vendor. HCA will work with any vendor you select to make sure your glass is available.

BID SUBMISSION: Absentee bids must be RECEIVED no later than Monday, September 28, 2009, at 5:00 PM local time. When using a credit card number, bids must be faxed to (740) 345-9638 using the absentee bidding form. When your Fax is complete, please contact the Museum to ensure it has arrived and is removed from the Museum Fax machine as soon as it arrives. The Absentee Forms with personal checks, et al, must be mailed to Absentee Bids, National Glass Heisey Museum, 169 W. Church St., Newark, OH 43055. HCA, Inc. must have credit card information or cash, a personal check, money order, or travelers check in its possession prior to executing a bid.

OTHER: The prices realized from this Auction will be printed in a future issue of the Heisey News. If you are not an HCA member but want to receive the results list, send \$2 and a long SASE. ♦

TERMS AND CONDITIONS OF SALE

1. THE MINIMUM STARTING BID PER LOT IS \$15
2. ALL LOTS SOLD IN NUMERICAL CATALOGED ORDER.
3. PAYMENT: CASH, TRAVELERS CHECK, CERTIFIED CHECK, PERSONAL CHECK, OR MONEY ORDER WITH POSITIVE ID. MASTERCARD OR VISA CARDS ACCEPTED. 5% BUYER'S PREMIUM. BUYER'S PREMIUM WILL BE DELETED FOR CASH, CHECK, OR MONEY ORDER PAYMENT. CASH ONLY PAYMENT MAY BE SPECIFIED FOR INDIVIDUAL AT HCA'S REQUEST.
4. HCA HAS ENDEAVORED TO DESCRIBE ALL LOTS TO THE BEST OF THEIR ABILITY - HOWEVER THIS IS NOT A WARRANTY. ALL LOTS ARE SOLD AS IS.
5. THE AUCTIONEER HAS THE RIGHT TO MAKE ANY VERBAL CORRECTIONS AT THE TIME OF SALE AND TO PROVIDE ADDITIONAL INFORMATION. INSPECTION IS WELCOMED DURING PREVIEW AND BEFORE THE LOT IS MOVED TO THE PODIUM FOR SALE.
6. IN CASE OF DISPUTED BID, THE AUCTIONEER HAS THE AUTHORITY TO SETTLE DISPUTES TO THE BEST OF HIS/HER ABILITY AND HIS/HER DECISION IS FINAL.
7. THE AUCTIONEER HAS THE RIGHT TO REJECT ANY RAISE NOT COMMENSURATE WITH THE VALUE OF THE LOT BEING OFFERED. LOTS ARE SOLD WITHOUT RESERVE, UNLESS ADVERTIZED OTHERWISE.
8. ALL SALES ARE FINAL. REALES WILL BE HANDLED AT THE AUCTIONEER'S DISCRETION. ALL ITEMS MUST BE PAID FOR THE DAY OF SALE. BUYER MUST HAVE PAID RECEIPT IN HAND TO PICK UP ITEMS.
9. BUYERS ARE RESPONSIBLE FOR ITEM ONCE THEY ARE SOLD UNLESS OTHERWISE SPECIFIED BY AUCTIONEER.
10. HCA IS LICENSED AS AN AUCTION FIRM BY THE OHIO DEPARTMENT OF AGRICULTURE AND BONDED IN FAVOR OF THE STATE.
11. HCA WILL PROVIDE AUCTIONEERS LICENSED BY THE OHIO DEPARTMENT OF AGRICULTURE AND BONDED IN FAVOR OF THE STATE.
12. BUYERS ASSUME FULL RESPONSIBILITY FOR ITEMS ONCE THEY ARE SOLD UNLESS OTHERWISE SPECIFIED BY AUCTIONEER.
13. BIDDING ON ANY LOT INDICATES ACCEPTANCE OF THESE TERMS AND CONDITION OF SALE. ♦



PERCY AND VIVIAN MOORE
ANNUAL MEMORIAL WEEKEND & DINNER
AND
THE 4TH ANNUAL HEISEY SELET AUCTION



A HEISEY HOMECOMING

Friday, October 2

Homecoming Dinner and Dance at the Buckingham House
6:00 p.m. Cash Bar and Appetizers
6:30 p.m. Dinner followed by a Special Presentation & Dancing

~ Menu ~

Honey Glazed Ham
Roasted Red Skin Potatoes
Baby Carrots
Salad
Beverages & Dessert
Price: \$35.00

Saturday, October 3

10:00 a.m. - Flea Market outside The Heisey Museum
Featuring Coffee and Rolls

2:00 p.m. - Select Auction at The Heisey Museum
Preview Begins at 12:30 p.m.
Auction Begins at 2:00 p.m.

Come and Have Fun
With All Your Heisey Classmates!!!



PERCY & VIVIAN MOORE
 ANNUAL MEMORIAL WEEKEND & DINNER
 AND
 The 4TH ANNUAL HEISEY SELECT AUCTION
A HEISEY HOMECOMING

OCTOBER 2 & 3, 2009



Come one, come all and bring a friend
 For Heisey Homecoming fun filled weekend!
 Get out your pompoms; find your letter sweater,
 Newark in the fall, what could be better?



We will start on Friday night with dinner and a dance.
 All things special about fall will be seen in a glance.
 Saturday morning you'll need a place to "park it"
 For at the museum, there will be a flea market.

Saturday afternoon will be the best of the best,
 Our select auction has gems, to that we can attest!
 So plan now for a great Heisey Homecoming
 Don't be left out or you'll be Ho Humming!!

(PLEASE PRINT)

NAME(S) _____

ADDRESS _____

CITY/STATE/ZIP _____

PHONE _____ EMAIL _____

HEISEY HOMECOMING DINNER & DANCE – FRIDAY OCT. 2

Number attending	x	Cost	=	Total
_____	x	\$35.0	=	\$_____

Registration deadline September 21.

WE WILL SEE YOU THEN AND THERE.
 HOMECOMING STUFF YOU SHOULD WEAR.
 HEISEY HAS BROUGHT US SO MUCH FUN.
 SMILES WE WILL WEAR WHEN WE ARE DONE.



HEISEY GLASS MUSEUM PLAYING CARDS

Edition 3 (green deck) of Heisey Glass Museum Playing Cards are now in. In addition, we have for sale a limited number of uncut sheets (21" x 25") which will be suitable for framing. This deck features the Heisey animals and animal related items. The full color pictures are stunning and will make a good learning tool as well as a nice gift for all of your glass collecting friends. We will ship as soon as available. Orders for Card Cases (Cobalt) and the Red deck may also be placed on this form.

Name _____
 Address _____
 City _____ State _____ Zip _____
 Phone and/or E-mail _____

I wish to order:	Total
_____ (number) Heisey Glass Museum Playing Cards (Green) @ \$10 each	_____
_____ (number) Heisey Glass Museum Playing Cards (Red) @ \$10 each	_____
Shipping per deck \$ 1.50 (can be picked up at Gift Shop)	_____
_____ (number) Uncut sheets of Heisey Playing Cards (Green) @ \$25 each	_____
_____ (number) Uncut sheets of Heisey Playing Cards (Red) @ \$25 each	_____
Shipping per uncut sheet @ \$5.00 each (can be picked up at Gift Shop)	_____
Grand Total (tax will be added when appropriate)	_____

Check # _____ Visa _____ Master Card _____
 Card Number _____ Exp _____

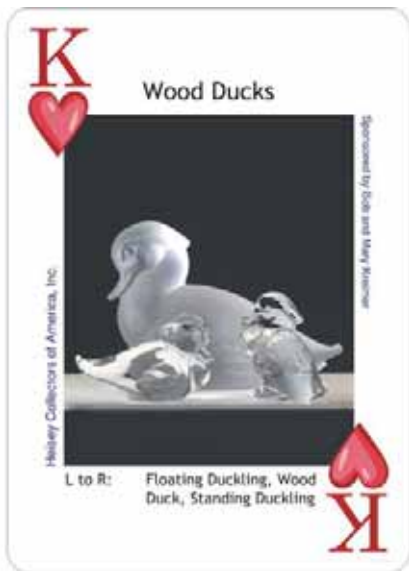
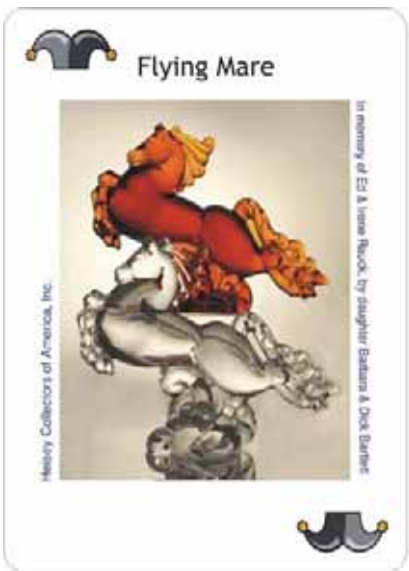

Study Club Directory

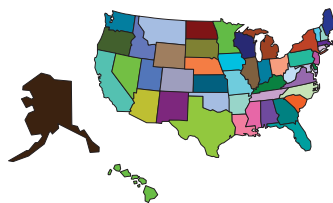

Interested in joining a study club? You will have the opportunity to meet fellow collectors and HCA members and learn more about your favorite glassware. If your club is not listed or you need to make corrections to your listing, please contact the Museum.

STUDY CLUB	MEET WHEN?	WHERE?	Email/Web Site	CONTACT
#4 Central Illinois Heisey Collectors Club	Four times a year	Members' homes or restaurants		Joyce Deany (815) 432-4310
#5 Bay State Heisey Collectors Club	2 nd Tuesday of each month except July, Aug., and Dec.	Whole Foods Community Rm, Bedford, MA	spescatore@houghton.com	Stephen Pescatore (978) 256-5418
#7 Dayton Area Heisey Collectors Club	3 rd Tues. of the month Sept. to May, 6:30 p.m.	Huber Heights Library	LH937@aol.com	Joe Harner (937) 372-0852
#8 Heisey Heritage Society <i>NJ, Eastern PA and DE areas</i>	Four times per year	Members' homes	craigkratochvil@aol.com	Craig Kratochvil (973) 962-4004
#13 Heisey Club of California	4th Sunday every month, 12:30	Members' homes	herbet@sbcglobal.net www.heiseyclubca.org	Norval Heisey (818)-349-0945
#14 Northern Illinois Heisey Club	Four times a year	Members' homes	niheisey@comcast.net	Jeff Morrow (630) 833-4644
#15 Heisey Collectors Club of Michigan	Every six weeks, August to May	Members' homes	kilgoredesigns@att.net	Sue E. Kilgore (269)-345-3990
#16 Heisey Collectors of Texas	2 nd Sat. of every odd month except May 1st Sat., 1 p.m.	Members' homes	sanddollars97@tx.rr.com www.heiseycollectorsoftexas.org	Greg Freeman (817)-545-5889
#19 Heisey Collectors of the Rochester Area	10 meetings per year: Sunday, 2:30 p.m.	Members' homes	seo2@aol.com	Sharon Orienter (585) 288-8076
#20 Buckeye Heisey Collectors Club <i>Newark, OH area</i>	September to May, 4th Monday	Members' homes or the Museum	Theflyingmaher@webtv.net	Michael Maher (740) 763-4256
#22 Northwest Heisey Collectors	First Saturday of the month	Members' homes	bahama50@hotmail.com	Deborah de Jong (425) 868-0457
#25 Heisey 76'ers <i>Columbus, OH area</i>	Once a month, September to May	Members' homes	ldburg48@aol.com	Colleen Burgess (614) 882-1884
#31 Nassau Long Island Heisey Club	Generally every other month	Members' homes		Babs Kent (516) 228-8274
#32 Dairyland Heisey Club	Once every two months	Members' homes		Ray K. Courtnege (414) 962-9747
#33 Golden Gate Heisey Collectors Club <i>Northern California</i>	Quarterly	Members' homes		Russ Nicholas (916) 515-8558
#36 Heisey Club of Southern MA	April, June, September, December			Maria Martell (508) 833-0633
#38 North Carolina Heisey Study Group	6 meetings per year: Jan.; March, May, July, Sept., Nov.	Replacements Ltd Greensboro, NC	Nchsg@yahoo.com www.northcarolinaheiseystudygroup.org	Karen Taylo (252) 637-9985
#39 Florida Heisey Collectors Club	4 times per year: January – February-March-April	Westchester Country Club Boyton Beach, FL	Shirley400@aol.com	Everett Dunbar (772)-337-1558
#42 Gulf Coast Heisey Club of Florida	Nov., Jan. and March; 2 nd Thursday 11:00 am	Members' homes		Jack Grenzebach (727)-391-5784
#43 Tri-State Heisey Study Club <i>OH, IN, MI</i>	1st Sat. every 3 rd month	Members' homes	Maxwellm@cktech.biz	Mike Maxwell (260) 925-3484
#45 Hoosier Heisey Club	Four times a year	Warren Library, Indianapolis, IN		J. David Litsey, (317) 872-7800
#48 Dixieland Heisey Study Club	Odd number months, 2 nd Saturday night	Members' homes	www.dixielandheisey.org	Craig German (770) 967-8733
#49 Great Plains Heisey Club	March, May, July, September, and November	Members' homes	cameron_mg@mchsi.com www.greatplainsheiseyclub.org	Mary Cameron (515) 292-3743
#50 Northwoods Heisey Club of Minnesota	Four times a year	Members' homes	wheise@comcast.net	Bob Heise (952)-831-9335
#51 Heisey Club of Northeast Florida	Feb., May, Aug., and Nov. 2 nd Thursday	Avonlea Antique Mall, Jacksonville	Clasyglas2@aol.com	Barb Bartlett (904) 280-0450
#52 Northern Virginia Heisey Study Club	Monthly, Sept. – May	Members' homes	rreopell@verizon.net	Russ Reopell (703) 250-6117

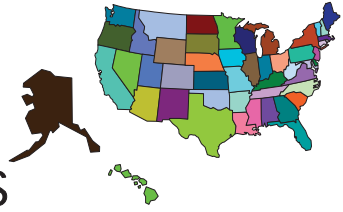

CLUB NOTES

Heisey Collectors of Texas
Erma Hulslander

Twelve Heisey Collectors of Texas were present at Lynn's home in Fairview, TX, July 11, 2009! A great turnout for vacation month, wedding month, etc.! President Greg thanked Lynn, for hosting our July meeting.

Our web site was shut down accidentally, the old domain, which was heiseycollectorsoftexas.com, was no longer available. However, we are now back on the web under heiseycollectorsoftexas.org, note the **org** – that is all we had to change to be up and running again.

We discussed what would be an appropriate piece of Heisey to place in HCA Museum in memory of John Powell. John's wife George Ann was at this meeting, so we knew she would know what would have pleased John. And she did, George Ann mention #503 Minuet etch was John Powell's favorite. So, we are writing to HCA, to see just what might be needed with this beautiful etching on it. John was a long time member in HCT and HCA, and very active member, I might add.

We had some delicious refreshments that Lynn had prepared, served on Heisey crystal, of course. And at this time we also checked out all the beautiful Heisey Lynn had in her home. Interesting note I want to share, brought back memories to Anne and Paul (HCT members now). They mention to me, that the first Heisey meeting they attended was at Lynn and her late husband Stan's home, back many years ago when they had just joined the National Capital Heisey Collectors Club. Both couples, after retirement, moved to Florida and were active in a Heisey Club there, and both have moved to Texas and joined HCT. Unfortunately Stan, Lynn's husband became ill and never was able to make it to a HCT meeting. But, isn't that wonderful to have such dedicated Heisey members through the years.

This "Show & Tell" was also our program this month, so many pieces were brought, and each one was described, which is how we learn to find that next piece of Heisey!

Candy & Greg went to Convention this year, so Greg gave us a mini-report on the 2009 Convention. So many things going on, they had a hard time getting to everything, but what they did get to was great, as usual! Many items they carried to the meeting came from the trip to Convention, before – during – after! How about a Sahara 4164 Gallagher jug with 447 Empress etch, and a Sahara 2351 Newton soda with 447 Empress etch! Dinner cup in No. 4044 New Era with a 825 Sea Glade cut, 1485 Saturn 2 light candleblock in crystal, 121 Pinwheel candlestick in Hawthorne, and a 126 Trophy candlestick in Flamingo. Also, a unusual 12" celery, only one person knew the pattern, it was 1447 Rococo. That is one you will have to check the book on!!! Salt shaker in 343 Sunburst, 112 Mars candlestick in Moongleam, 1552 Four Leaf candlestick and they had to get at least one animal, which was a cute little Heisey bunny head up! I would say they had quite a trip!

Sim did not go to the Convention, but he had some goodies too. First of all, I have to tell you about the piece that all of us were in shock. This was when he pulled out a 7 ½" Electro-portable satin shade with Heisey No. 1 cutting. We just so happen to have a few members in HCT that needs that Shade – but Sim needed it also. No one could talk Sim out of that one, but what a treat to see one, which I have to tell you, he found it at a big flea market, not a antique show or mall! More goodies, 1184 Yeoman 7" low footed comport with beautiful cutting, 9" high footed 1235 Beaded Panel & Sunburst bowl, 3362 Charter Oak 8oz. luncheon goblet in Flamingo, and a Moongleam 1405 Ipswich 2 handled sugar bowl and 6" underplate, a Sahara 1469 Ridgeleigh cigarette box and cover, a 1506 Whirlpool 2 ½" individual nut (really different), and a 300 Peerless spoon tray. Candlesticks in 22 Windsor 7 ½" with unknown cutting, and a pair of 100 Centennial 6", stained yellow with gold trim – cut to clear and signed HAWKES and with the Diamond H, this is something you don't find every day either!

How about having a friend whose crystal was Heisey Crystolite for years and she decides to give it to her friend, who also has the same pattern? That happen

to Madeline, and as she unpacked the boxes, the pieces she did not have she shared with us today, and this is the No.1503 1/2 coffee or tea cup with saucer, which is kind of the hard-to-find set. This is what I call a "great friend"!!!

Sim also enlighten us all with a beautiful Ruby Rose Bowl, No. 230 Neapolitan Line, circa 1890, by Hobbs, Brockunier. Sim collects a lot of different glass, and has a great library to identify pieces of glass from many glass companies. So, Sim and his wife Betty have invited us all to head south to their home in lola, TX in September. The program will be "ID," bring along any Heisey or other piece you may want to be identified! This will be very enjoyable learning experience; don't miss it – September 12 at 1 p.m. in lola, TX!

Hope to see ya'!!! Until then, Happy Heisey Hunting! God Bless! ♦

Heisey Collectors Club of Michigan
Dan Kilgore

It turned out to be a very special meeting at our August 8 meeting at Jack & Marge Deppongs Houghton Lake home. Our special guests were Bill & Marie Burden from Mt. Pleasant and their daughter and son-in-law, Betty & Virgil Commer. Bill, who will be 102 on August 25, is a former Heisey factory worker. At the age of 16 (in 1922) he started work by opening and closing the molds for the glass to be put or taken out of and then later worked for the blowers. He also remembers working in the cooling area where the glass was immersed in water baths. His favorite story was about being hidden when inspectors came to the factory as he was under age. His supervisor hid him in the cooper shop until the inspectors were gone. He explained that in those days the cooper shop made barrels to ship the Heisey glass. Bill became familiar with the Heisey family much earlier than his employment at the factory however, because he delivered an abundance of telegrams to the Heisey's Granville Street home when he worked as a Western Union delivery boy. Bill resided at the corner of Russell and O'Bannon Streets with his parents and his sister Margaret (Cochran) and attended the Hazel Street School. Margaret who is now 92 was also an employee of the Heisey factory and she resides in Mt. Vernon, Ohio. She longs to see the Heisey Museum and would love to attend the former

employee's reception during Convention. We have given Bill our assurance that we will contact her and see to it that she gets to the reception, but only if we can stop by the Velvet Ice Cream factory. His eyes lit up with delight at the memory of the ice cream factory. Bill and Marie remain in good health, have never needed glasses and attribute their long lives to Marie's cooking; nothing store bought, cooked from scratch, always fresh and in moderation. Bill and Marie will celebrate their 76 anniversary on August 28. It was a delight to have them with us.



**Former Heisey Worker Bill Burden
and his Wife Marie**

As Bill and Marie sat in straight back chairs we conducted our meeting for the next two hours. Present were the Ernests, Kilgores, Pages, Parretts, Roses & VanMeers. A happy anniversary was extended to Jack & Marge on their 47th years.

We reviewed the 2009 Convention. Interesting discussion evolved from dealers and collectors view points. We all agreed that it was a well run, organized and friendlier experience. Many commented on the fun opening picnic at the park, what a great job Walter did presenting the etching seminars and are glad to see the success of the Saturday morning on the Square event. Thank you Mary Ann and Judy convention chairs, once again.

All members were encouraged to attend the Moore weekend in Newark, October 2 and 3.

Fund-raisers in support of HCA were discussed. Mary Parrett reported that the tea towel sale at convention was a big success. Thirty-two towels

were ordered and have been shipped. Sales of the towels, note cards, and calendars brought a profit of \$227.72 for our club. Discussion turned to how to proceed with this aspect of fund-raising. Mary and Diana plan to continue taking orders and possible exhibit sample in the Museum Gift Shop. Ruth Ernest showed us an embroidery sample of the diamond H for possible use on items for sale. Everyone was impressed with the quality and accuracy. Sue suggested we start with canvas bags with the embroidery.

Discussion turned to what to do with our treasury. Mary made a motion that the secretary ask the BOD what special projects are in need of funds. The information should include priority and costs

Everyone enjoyed the food provided and showed off their new finds. Bill and his family loved looking at the Heisey and the Deppongs collection. ♦

Advertising Guidelines:

Advertising: Ads may be mailed to: HCA Advertising, 169 W. Church St., Newark, OH 43055; faxed to (740) 345-9638; or e-mailed to curator@HeiseyMuseum.org. Whenever possible, please e-mail your ad. Include your MasterCard or VISA number and expiration date for billing purposes, or send a check. All ads must be prepaid. When mailed or faxed, ads should be typed or printed on white paper with dark ink. Please double space. Ads that are entered in a vertical column format may contain a maximum of 65 characters per line, including spaces & punctuation.

Classified: 20 cents per word (members), 30 cents per word (non-members), \$1.50 min., 1/8 page limit. Personal ads 1/8 page limit. Abbreviations & initials count as words.

Display Ads:	member	nonmember
1/8 page (12 lines)	\$ 20	\$ 30
¼ page (25 lines)	\$ 40	\$ 60

½ page (60 lines, horizontal or vertical)	\$ 80	\$120
---	-------	-------

Full page (120 lines)	\$160	\$240
-----------------------	-------	-------

A charge of \$1.60 will be added for each additional line.

½ page: 4½" high by 7½" wide or 9" high by 3½" wide

Full page: 9" high by 7½" wide

Ad copy must be received by the first of the month prior to publication. Reproductions (i.e., Heisey by Imperial) must be indicated. Heisey News accepts no further liability. In the event of a typographical error, the incorrect portion of the ad will be run in the following issue, but HEISEY NEWS assumes no further liability.

Abbreviations: DF=Dolphin Foot NO=Narrow Optic
DO=Diamond Optic SO=Spiral & Saturn Optic
MO=Medium Optic WO=Wide Optic

Classified Ads

Find the Best of Heisey Glass...

...with popular patterns like Orchid, Heisey Rose, Minuet, and hundreds more. We also carry other fine crystal and depression glass from Cambridge, Fostoria, Imperial, Duncan & Miller, and more. The world's largest supplier of old and new china, crystal, flatware and collectibles, Replacements, Ltd. carries over 11 million pieces in inventory in over 250,000 patterns.

If you're looking to add to your collection, or if you're looking to sell — call us toll-free. We're always looking for more.



1-800-REPLACE (1-800-737-5223)

♦ *Paid Ad*

REAL HEISEY IN THE GIFT SHOP

All crystal and all prices are each unless noted.

Supply changes daily. Please contact the Gift Shop before placing an order.

Item	Price
53 Tall Individual salt shaker/glass top, All Mglm	\$20
134 Trident 2 lt candlestiks, silver overlay, pr	40
337 Touraine wine, H (2 each)	10
341 Puritan individual salt (4)	8
394 Narrow Flute 4 ½" chow chow, H	25
394 Narrow Flute salted nut, H	10
475 Narrow Flute/Rim salted nut, plain bottom H	15
500 Octagon tray, 6", Moongleam	10
1205 Fancy Loop wine	18
3480 Koors cocktail, Moongleam ft	10
3480 Koors soda, 8 oz with Wheeling "Pheasant on Stump" in gold, Flamingo (4 each)	15

NEW IN THE GIFT SHOP

Reprint of Catalog and Price List No. 31, September, 1950	\$12.95
Heisey Placemats (produced by Bay State Heisey Club)	\$14 each or 2 for \$25
Heisey Notecards, 12 cards each with a different Heisey etching plus envelopes	\$12

♦

Dealer Directory

Maximum 6 lines/12 months/\$35 MEMBERS ONLY

Contact the Editor to place your ad!



<p>KIM & PAM CARLISLE SHOWS & MAILORDERS ONLY 28220 Lamong Rd. Dept. H Sheridan, IN 46069 Glass Cleaning Services Available (317) 758-5767 kcartist@worldnet.att.net</p>	<p>SHIRLEY EUGENIA DUNBAR Heisey a Specialty—Mail Order, Shows, Appraisals EMAIL: shirley400@aol.com PO Box 8344, Port St. Lucie, FL 34952 Oct-May (772) 337-1558 PO Box 222, Naples, ME 04055 May-Oct (207) 647-5652</p>	<p>SUM OF LIFE Elaine Husted: 610-469-1243 Traveling through eastern PA Call, stop in, be a buyer or a browser!! E-mail: 1classycat@comcast.net</p>
<p>ALL HEISEY AUCTION Consignments Welcome Apple Tree Auction Center 1616 W. Church, Newark, OH 43055 (740) 344-4282</p>	<p>MOUNDBUILDERS SECOND GENERATION Barbara and Richard Bartlett Heisey Exclusively! 1-904-280-0450 PO Box 1931, Ponte Vedra Beach, FL 32082 Toll Free 1-888-434-7397(HEISEYS) EMAIL: CLASYGLAS2 @AOL.COM</p>	<p>EAGLES REST ANTIQUES Buying Heisey, China & Pottery Carl and Mary Evans 62 Fieldpoint Rd., Heath, OH 43056 (740) 522-2035</p>
<p>PAULA & JEFF MORROW Elegant Glassware and American Dinnerware 126 Clinton Avenue Elmhurst, IL 60126 (630) 833-4644 mor-fab@comcast.net</p>	<p>H & R DIAMOND H Helen & Bob Rarey 1450 White Ash Dr. Columbus, OH 43204 (614) 279-0390 after 5:30</p>	<p>CRYSTAL LADY Bill, Joann & Marcie Hagerty Specializing in elegant depression glassware 1817 Vinton St., Omaha, NE 68108 Shop (402) 341-0643 or Home (402) 391-6730 Email: ejhagerty@aol.com website: www.crystalladyantiques.co</p>
<p>REALMS IN GLASS Roy Eggert Heisey Custom Stained Glass 9423 Saddlebrook Ct, Frederick, MD 21701 301-260-0234 roy54@hughes.net</p>	<p>PIECE BY PIECE ANTIQUES Buy & Sell Specializing in Heisey Glassware Bryan K. Baker Fairfax Station, VA 22039 Newark, OH 43055 (703) 250-6117 piecebypiece@verizon.net</p>	<p>PATTON HOUSE ANTIQUES Specializing in Glass*Heisey*Cambridge*Fostoria*Duncan* Factory Antique Mall, Verona, VA off I-81 Exit 227 Antiquers Mall, Booth 81, Rt. 29 N., Charlottesville, VA The Daniels, Box 547, Louisa, VA 23093 (540) 967-1181</p>
<p>C&J ANTIQUES Cole & Jean Miesner Box 45, 72 Whig St. Newark Valley, NY 13811 (607) 642-9905</p>	<p>SIBYLS OF WILMINGTON Sibyl & Ned Lavengood at Castle Corner Antiques 555 Castle St. Wilmington, NC (910) 264-9597 or Sibylsantiques@bellsouth.net</p>	<p>FRAN'S FANCY FINDS Fran & Jack Grenzebach 10534 Valencia Rd., Seminole, FL 33772-7511 (727) 391-5184 SHOWS MAIL ORDERS</p>
<p>The American Bell Association P.O. Box 19443 Indianapolis, IN 46219-0443 www.americanbell.org m</p>	<p>PASTICHE ANTIQUES at Preston's Antique Gaslight Village US 12, Allen, MI 49227 Elegant Glass and Other Fine Antiques pasticheantiques@gmail.com</p>	<p>WILLEY'S ANTIQUES & MUSEUM Specializing in Heisey 11110 Cannon Rd., Frazeeburg, OH 43822 16 miles east of Newark, OH (740) 828-2557</p>
<p>CHARLES & MILDRED FISHER Heisey animals and Heisey By Imperial animals 1607 Dayton Rd, Newark, OH 43055 Cfisher08@roadrunner.com (740) 281-3104</p>	<p>MARSH'S ANTIQUES Dick and Virginia Marsh 4532 Newton Road Newark, OH 43055 swamp@alink.com (740) 366-5608</p>	<p>MOONGLEAM ANTIQUES Heisey Glassware & American Art Pottery John Woytowicz and Peter Rivard 70 Pleasant St., Gardiner, ME 04345 (207) 582-9048 E-mail: jmwpwr@aol.com</p>
<p>ROBERT M. LOCH Voting Member HCA and NWHC Pacific Interstate Glassware Co. PO BOX 469 Custer, WA 98240 360-366-3166</p>	<p>CRESTONE MANOR UNIQUES Harold & Loleta Hammontree 3317 Crestone Circle, Chattanooga, TN 37411 423-629-1274 hammonl@bellsouth.net Heisey Only</p>	<p>APPLE VALLEY COLLECTIBLES Richard & Marilyn Garnett – Owners Shows/ Mail Order (845) 691-8799 Email: diamondH95@aol.com</p>
<p>DOWNSTAIRS AT FELTON ANTIQUES 100B Felton St, Waltham, MA 02453 781-894-2223 info@feltonstreetantiques.com GLASSWARE, POTTERY, EPHEMERA, STERLING, FURNITURE FROM EVERY DECADE!</p>	<p>WM GLASS Bill & Mary Barker 400 Nantucket Ave., Pickerington, OH 43147 (740) 927-0918 mcbarker@embarqmail.com Heisey Only</p>	<p>WATERSEDGE ANTIQUES Norene & Don Walzer Shows & Mail Order 25089 Riverwalk Drive Leesburg, FL 34748 (352) 314-8975 dnnwalzer@embarqmail.com</p>
<p>JERRYS' ANTIQUES Shows Only Glassware and Other Fine Collectables PO Box 4485, Davenport, IA 52808 563-340-1871 jerrysantiques@mchsi.com</p>	<p>ONCE AND FUTURE ANTIQUES Susan & Stephen Pescatore 9 Donna Rd. Chelmsford, MA 01824 (978) 256-5418 Heisey and Elegant Glass</p>	<p>BOB & MARY KREIMER Specializing in Heisey Glass 7044 SW 116th Loop, Ocala, FL 34476 (352) 873-8306 email: rkreimer@earthlink.net. Shows and Mail Orders Only</p>
<p>J & L TREASURES Specializing in Heisey, Cambridge, Fostoria, Tiffin, Morgantown, etc Linda Kilburn, PO Box 1257, Burlington, CT 860-673-4088 jltreasures@comcast.net</p>	<p>Charlene Bowman Shows Only Heisey – Cambridge – Fostoria - Morgantown P.O Box 287, Clarksville, OH 45113 937-289-2114 twoclbs@aol.com</p>	<p>YELLOW BRICK ROAD ANTIQUES Jean Will Leavenworth, KS 66048 (913) 682-4831 Specializing in Heisey and Elegant Glassware Shows and Estate Sales</p>
<p>Just in Time Antique Mini Mall 29 North Third St Newark, OH 43055 Heisey in Stock 740-349-0001 ntleblanc@aol.com</p>	<p><i>Your Ad Could be Here</i></p>	<p><i>Your Ad Could be Here</i></p>

When Renewing Your Membership

Help ensure the future of your Museum. When you renew your membership at one of the levels below, any amount beyond the regular Associate dues goes into the Endowment Fund.

<i>Individual Contributing, one person in household</i>	<i>\$50</i>
<i>Joint Contributing, two people in one household</i>	<i>\$60</i>
<i>Family Contributing, parents and children under 18</i>	<i>\$75</i>
<i>Patron</i>	<i>\$125</i>
<i>Sponsor</i>	<i>\$250</i>
<i>Benefactor</i>	<i>\$500</i>

Visit The
National
Heisey
Glass
Museum



Come at your leisure to enjoy more than 4,800 pieces of glassware produced by A.H. Heisey and Company from 1896-1957. Hundreds of patterns are featured in all production colors. Rare and experimental items are included as well.

Facilities are air-conditioned and handicapped-accessible. Hours are 10:00 a.m. to 4:00 p.m. Tuesday through Saturday, 1:00 to 4:00 p.m. Sunday (except Jan. and Feb.). Members are admitted free, regular admission is \$4. Office hours are 8:00 a.m. to 4:30 p.m. weekdays.

Membership Renewal Notice: Check the date above your name and address on the mailing label. This is your expiration date. If it reads 9-10-09, make sure your dues are paid soon in order to receive next month's issue of *Heisey News*.

Contact the HCA Administrative Office at (740) 345-2932 for more information. The Endowment Committee wishes to thank those who have become Endowment Members and all of the individuals and study clubs that have so generously supported the HCA Endowment Fund. All members who have supported the fund are recognized each year in the February issue of the Newsletter. Your support will make the Museum self-sustaining in the years to come. Thank You all! ♦

Shipping & Handling Fees for Outside US

Additional shipping charges are required for members living outside the U.S. Current rates are Canada, \$22; for other countries, contact the Museum. Rates are subject to change at any time due to rate changes made by the US Postal Service. To verify current rates, call (740) 345-2932 or E-mail business@HeiseyMuseum.org



Periodical Postage

Paid at the Post Office
In Newark, OH 43055
Publication # 00986
POSTMASTER SEND FORM 3579 TO:
HCA
169 W. Church St.
Newark, OH 43055

To: _____

Museum Volunteers for July 2009

Charlene Bowman
Chuck & Amy Jo Jones
Frank Kuhlmann
Dick & Virginia Marsh
Phyllis McClain
Ginny Priest
Dick & Marilyn Smith
Dave & Mary Ann Spahr
Karen Taylo