

HEISEY NEWS

The Official Publication of Heisey Collectors of America, Inc.

Volume XXXVIII No. 5

May 2009

ISSN 0731-8014

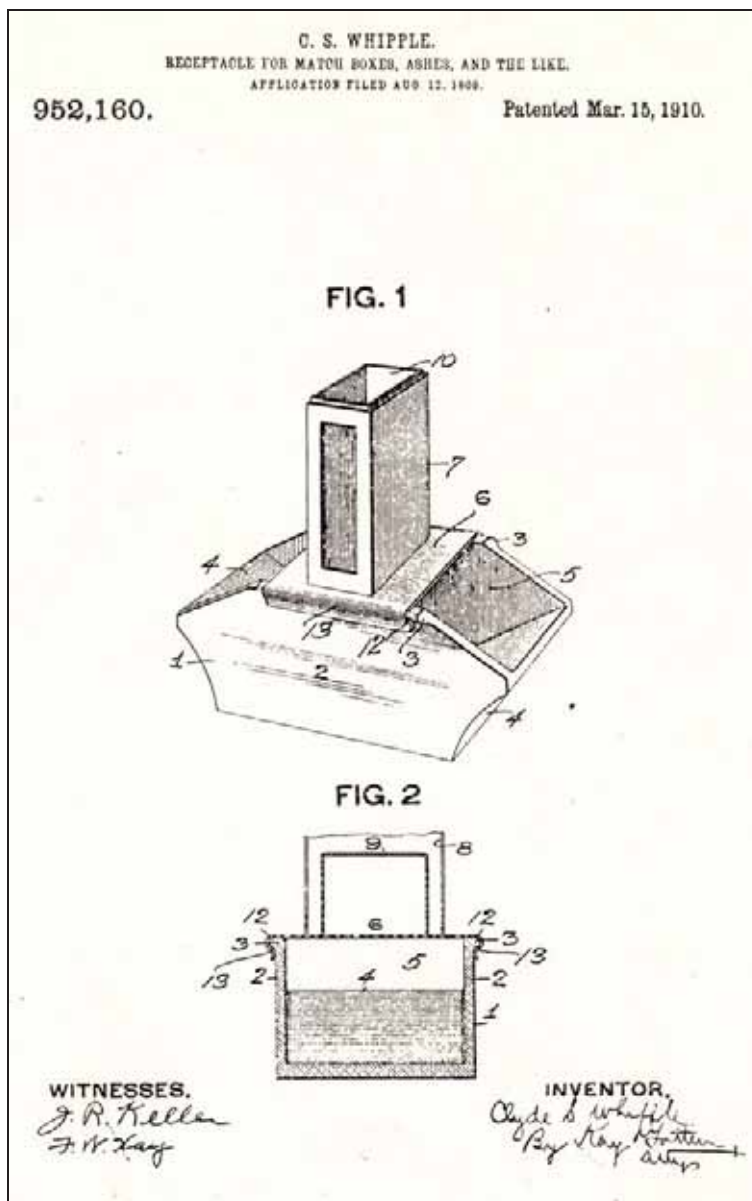

Patent 952,160

Read Part Three of the Story of A. H. Heisey Utility Patents on Page 5

HEISEY NEWS

Heisey Collectors of America, Inc.

169 West Church Street

Newark, Ohio 43055

Phone 740-345-2932 Fax 740-345-9638

Web Site: www.heiseyMuseum.org

All Rights Reserved 2009

ISSN 0731-8014

Staff and Phone Extensions

Curator, Walter Ludwig, curator@heiseyMuseum.org, Ext. 4

Clerks, Justin Church, Amanda McDonald

membership@heiseyMuseum.org, Ext. 1

Gift Shop, Ext. 5

HCA Board of Directors:

President, Bryan Baker - Fairfax Station, VA, 703-250-6117 –

hcapresident@heiseyMuseum.org

Vice-President, Charlie Wade – Newark, OH 740-587-2002

Secretary, Amy Jo Jones - Beavercreek, OH, 937-426-1567

Treasurer, Sharon Orienter – Rochester, NY, 585-288-8076

Member-at-Large, Dave Spahr - Xenia, OH, 937-372-7166

Sid Edwards – Tallassee, AL, 334-283-4663

Tom Files – Kansas City, MO, 816-468-7087

Ron Keener – Heath, OH, 740-323-3747

Sue Kilgore – Kalamazoo, MI, 269-345-3990

Robert Loch – Custer, WA, 360-366-3166

Jack Metcalf – Utica, OH, 740-892-2664

Karen Taylo – New Bern, NC, 252-637-9985

HEISEY NEWS is published and printed monthly (twice in March), by Heisey Collectors of America, Inc. (HCA). Periodical postage paid at Newark. Subscription is limited to HCA members. First class mailing is available for an extra \$20.00, due with payment of membership. If you are having difficulty receiving your Newsletter, please contact the HCA Administrative Office Monday through Friday 8:30 a.m. - 4:30 p.m.

The opinions expressed in articles in HEISEY NEWS are those of the authors and not necessarily those of the organization. The Editorial Staff reserves the right to edit, with or without the consent of the author or to refuse any material submitted for publication.

Back Issues

Back Issues available from files are \$3.00 per issue plus shipping and handling

Advertising

Ads may be mailed to: HCA Advertising, 169 W. Church St., Newark, OH 43055; faxed to (740) 345-9638; or e-mailed to curator@HeiseyMuseum.org. Whenever possible, please e-mail your ad. Always include your MasterCard or Visa number and expiration date. When mailed or faxed, ads should be typed or printed on white paper with dark ink. Camera ready ads are accepted, but must follow line specifications outlined at the beginning of the advertising section. Ads containing reproductions will not knowingly be accepted unless clearly stated (e.g. Heisey by Imperial, etc.). HEISEY NEWS accepts no further liability. In the event of a typographical error, the incorrect portion of the ad will be run in the following issue, but HEISEY NEWS assumes no further liability. See advertising section for rates and deadlines.

Museum

Heisey Collectors of America, Inc., a non-profit corporation (tax-exempt status), owns and operates The National Heisey Glass Museum in Veterans Park, 6th and Church Streets, Newark, Ohio. Open year round, Tuesday through Saturday 10:00 a.m. – 4:00 p.m., Sunday 1:00 – 4:00 p.m. (except Jan. and Feb.), closed holidays. Other hours by appointment. Members admitted free.

Identification

HCA will attempt to identify unknown glass items. Send a color photograph, measurements, and a self-addressed, stamped envelope to the attention of the Curator. Other arrangements should be made in advance with the Museum staff. Please keep in mind that the Museum cannot appraise items. Identification is free to members, non-members \$5.00 per item.

Membership

To join Heisey Collectors of America or to renew your membership, contact the HCA Administrative Office Monday through Friday 8:00 a.m. - 4:30 p.m. Eastern Time. Associate dues are \$30.00 plus \$5.00 for each additional household member. Voting members pay an additional one-time fee of \$25.00. Please consider supporting the Endowment Fund by joining at one of the levels listed on the back page.

Museum Gift Shop

There is always someone in the Gift Shop during the Museum's hours of operation to help answer questions or take orders. When ordering by phone, please have a credit card ready. When ordering by mail, please be sure to include appropriate charges such as shipping and sales tax. Please note that the HCA member discount does not apply to original Heisey or special project items.

Shipping and Receiving

Delivery is made much easier when we have a complete street address, not a PO Box. We prefer to use UPS. If you have not received a package, please call the Administrative Office to confirm it was sent. We will assist you in tracing it. If your package arrives damaged, please contact your local UPS representative. We insure everything.

Donations and Loans to the Museum

If you would like to make a donation to the Museum or have questions regarding items on loan, contact the Curator. HCA reserves the right to accept or refuse items based on current holdings.

HEISEY CALENDAR OF EVENTS

2009

Select Auction List Submission Deadline	May 18
Convention Registration Deadline	June 4
Absentee Ballot Deadline to Have at Museum	June 18
Heisey National Convention and Elegant Glass Show Newark, OH	June 17-20
Percy and Vivian Moore Memorial Weekend	October 2-3
2009 Fifth Heisey Select Auction	October 3
December Holiday Open House	December 5

Table of Contents

Utility Patents Associated with A.H. Heisey & Company (Part 3), Walter Ludwig	FC & 5-7
Heisey Calendar of Events	2
Message from the President, Bryan Baker	3-4
Curator's Report, Walter Ludwig	4
379 Urn, Joe Lokay	8-11, 17
Benefit Auction Wrap-Up, Dave Spahr	12
2009 Benefit Auction Results	13-14
2009 Candidates for the HCA Board of Directors	15-16
2009 Benefit Auction Pictures	16
2009 Fifth Annual Heisey Select Auction	17
HCA Welcomes New Members for March 2009	17
2009 Select Auction Glass List	18
2009 HCA Convention – Register Now!! Co-chairs, Judy Rhoads and Mary Ann Spahr	19
2009 Convention Schedule of Events	20
HCA Convention 2009 Registration Form	21
Heisey Glass Museum Playing Cards, Order Form (Green Deck)	22
Club Notes	23-25
Advertising Guidelines	25
Classified Ads	25-26
Dealer Directory	27
Museum Volunteers for March 2009	BC

MESSAGE FROM THE PRESIDENT

Bryan Baker

I can't get over that May is already here – didn't we just celebrate New Years? I remember my parents telling me as a child to appreciate each day, for as you get older time seems to go by faster and faster. My, how they were right!

Our Benefit Auction has come and gone. It was great seeing all the friendly faces of fellow collectors and Heisey enthusiasts. Bidding was spirited and it looked like everybody walked away with a treasure. There certainly was a wide range of glass pieces so that all who were there could find something to satisfy their collecting taste. I want to thank our auction chair Dave Spahr, the countless volunteers, our consignors, and, of course, all those hands that went up in the air to bid! Many thanks go out to our absentee bidders as well!

It seems the Benefit Auction is the kickoff event of the Heisey season. Our annual Convention is a mere month away. With each meeting in which we hammer out all the details with our Convention chairs, Mary Ann Spahr and Judy Rhoads, it becomes clearer that this will be a Convention for all – old and new alike. Now when I say "old and new," I'm strictly referring to those who have been to Convention many times before and to those for whom this may be their first Convention. We want to make sure all feel welcome, but this year we want to ensure that our first-time Convention goers don't get lost in the Heisey shuffle so to speak. This year we will have mentors available to assist our freshman attendees. We want to make sure they are able to enjoy all that Convention has to offer.

Having said that, maybe this is the year for those reading this to make your reservations and join us in Newark, Ohio. We really are a friendly group and would be very excited for you to take part in this fantastic week! I remember my first Convention; it was a little intimidating at first,

but by week's end I just did NOT want to go home. I've been attending Convention ever since. Please go to pages 20-21 in this Newsletter for a schedule of events and all the information you need to register.

Convention not enough? How about joining us back in Newark on October 2 - 4 for our Annual Percy and Vivian Moore Memorial Weekend and Dinner? Even though Convention has yet to come, we are underway with planning this fun weekend. The Annual Select Auction will be held on Saturday, October 3, and is sure to have something in it for you to add to your collection. More details on that weekend will be coming soon.

I want to take this opportunity to tease you all with something we have in the works. Our Curator, Walter Ludwig, is taking the lead on a new exhibit in our Museum that will be focusing on the Heisey factory. We are very much in the infancy on this project, but it merits mentioning. I have all the confidence in the world that it will be breathtaking when complete.

Another project that I do expect to be nearing completion, at least the first stages, is the redesign of our website. The development team has been doing a terrific job; the home page is essentially complete and work is under way on the remaining pages. As I've shared with you before, we hope to add more functionality to the site and make it more user friendly in addition to a more useful tool for our membership and public at large.

Word has reached us of the death of Jim Gartner of Delaware who was a long time member of HCA. Our thoughts are with his family at this time.

My term as your president will end in June. Working with the board, staff, and members; we've been able to get Heisey in the Ohio Governor's Residence, given the collection in the Museum a new look, obtained new computers and software, and so on. These two projects; web redesign and exhibit, I hope to have well under way before leaving. All of

these efforts are the result of working together for a common good. My goal has been to effect positive actions for the organization, and it cannot be done alone. Many thanks to all that have done so much for HCA and the Museum.

Until next time,

Bryan Baker ♦

CURATOR'S REPORT

Walter Ludwig

I was complaining about the cold just a month ago, but now the plants are beginning to bloom and it is looking great outside. So great, in fact, that I am going to have to get out the lawn mower over the weekend just so I can see the green grass and not a field of yellow dandelions. Already, the rhododendrons in the Museum courtyard have given up their purple blooms and the daffodils are beginning to fade. But, there are so many others yet to show off their finery before they too give way to later blooms. This is the reason that I like living in the northern part of the United States, the change of the seasons is such a great display.

We have just wrapped up a very successful Benefit Auction here in Newark. It is always great when Heisey folk get together for these events. Many of you traveled quite a distance to be here with us and it is appreciated. Because of the high quality in this auction, HCA was able to surpass its budgeted expectations for this fund-raiser. This is so important in keeping the Museum in good economic health in these times. Many pieces brought excellent prices and you can see the prices realized in the auction in this issue on pages 13 and 14. These numbers are also available on our web site. By the way, if anyone found a 9" Empress Moongleam celery in their box of items picked up at the auction, we would appreciate it if you would contact the Museum. This item was missing when we went to pack up the glass for the absentee bidders.

Convention is now just a bit over a month away and we really have a great one planned for you this year. I have something rather exciting to announce to you concerning Convention. I have been in contact with one of the Krall family members. The family has agreed to lend some of the family owned Krall cut pieces to the Museum so that we may display them during Convention this year. I will be putting them into a case in the Multi-Purpose Room so that all may see these treasures when they stop by for refreshments. This will be a rare opportunity to see these pieces.

As you know, the theme of this year's Convention is "Artistry in Glass: The Heisey Etchings." The Museum has a very good collection of etched Heisey pieces but we do not have examples of all of the ones that Heisey made. Search your collections and see if you can either lend or donate an example of one of these etches that the Museum does not have. Even if you can only bring it to the seminars to be shared with other collectors it would be appreciated. Missing needle etches include 1 Braid, 17 Zig Zag, 19 Double Loop, 27 Crochet, 31 Roman Key, 35 Lacy Band, 38 Tallahassee, and 41 Braided Loop. Missing pantographic etchings include 151 Zeus, 155 Neptune, 158 Barcelona, 161 Somerset, 164 Salem, 169 Biltmore, and 172 Dover. Early plate etchings include 342 Barberry, 343 Julie, 349 Margaret, 350/351 Mums, 352 Anne, 370 Nile, 384 Iroquois, 314 Zouave, 402 American Beauty, 403 Chartiers, 404 Muskingam, 406 Duquesne, 407 Morning Glory, 408 Lincoln, 415 Classic, 421 Rose, 422 Cumberland, 423 Violets, 425 Dogwood, 428 Simplex, 432 Londonderry, and 433 Dutchess. Later etches include 453 Inca, 457 Springtime, 461 Concord, 509 Lily, 512 Helen, and 518 Pan American Lei.

I hope everyone is visiting those outdoor flea markets now that the weather is fine. I am sure there is a treasure out there for you. Remember that it will not find you, you have to go out and find it. ♦

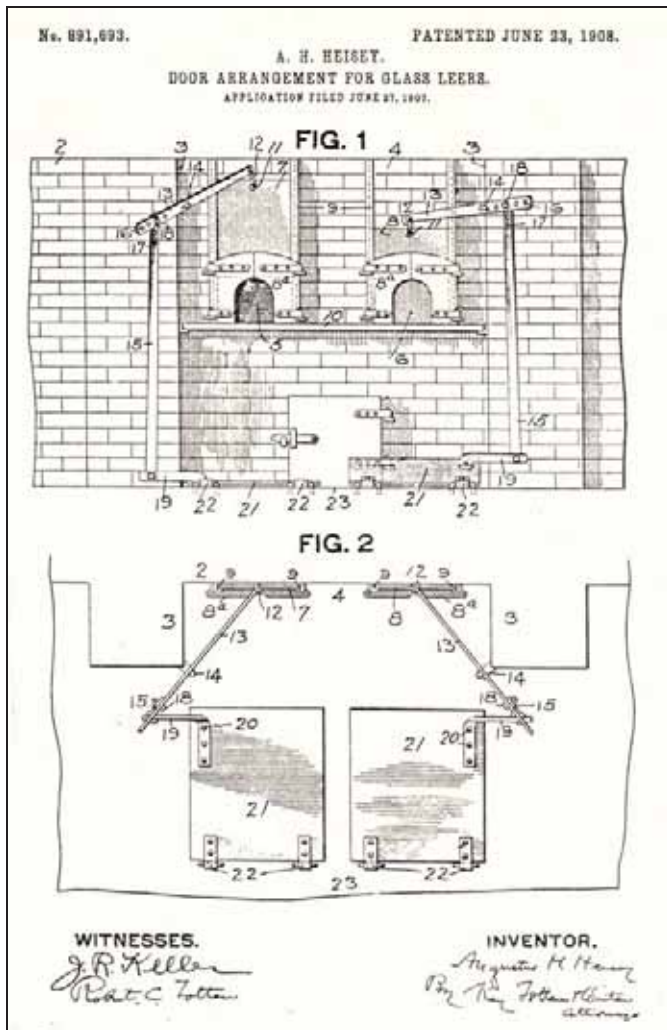

Patent 891,693

The first patent we will look at is No. 891,693 which was granted on June 23, 1908, with Augustus H. Heisey of Idlewood, PA, listed as the inventor. It is interesting that even at this late date A. H. had an address in Pennsylvania. The invention is described as a "door arrangement for glass-leers (sic)." We are accustomed to spelling the cooling or annealing ovens at the factory as "lehrs" now, but obviously "leers" was an acceptable alternative spelling at that time. The traditional doors on a lehr were swinging doors that were left open while the glassware was loaded into the lehr. The innovation that the patent covers is the installation of a sliding door behind these swinging doors that was operated by a platform upon which the loader had to stand to insert the glassware into the lehr. This prevented the introduction of cold air into the hot lehrs and therefore cut down on the amount of waste of heat and breakage of ware. This is all very ingenious given that the person loading in the ware would be carrying the hot ware that was prepared by the molders and he would not have his hands free to operate levers to open the doors. Now his own body weight as he approached the lehr would open the door as he stepped on the platform.

UTILITY PATENTS ASSOCIATED WITH A.H. HEISEY & COMPANY (PART 3) Walter Ludwig

We will continue to look at the utility patents that were issued to people associated with A.H. Heisey & Company or which were assigned to the factory. The patents we will look at in this article were granted in the period 1908-1910. We have one patent for a new design for lehr doors, one for a combination metal and glass ashtray, and then several more dealing with innovations in the methods of finishing glass. It is obvious that any efficiency that could be achieved in the finishing process of making the glass would mean both a better product and savings in terms of labor costs.

The next patent is No. 952,160. This patent was granted on March 13, 1910, to Clyde S. Whipple of Portland, Indiana, and assigned to A. H. Heisey & Co., Inc, a corporation of West Virginia. It appears that Mr. Whipple had an ingenious idea to combine a glass receptacle with a metal stand to make a combination match holder/ashtray. He must have brought it to Heisey who probably paid Whipple for his invention and the right to manufacture it. Since the metal parts to this piece were not made at Heisey, Mr. Whipple may have had something to do with the manufacture of the metal part of the invention. Heisey did produce and market this piece as the 352 Flat Panel match stand. It appears in Catalog 76 (1915). Interestingly, the bottom was sold separately by Heisey as the 424 almond dish (see Vogel IV, page 157).

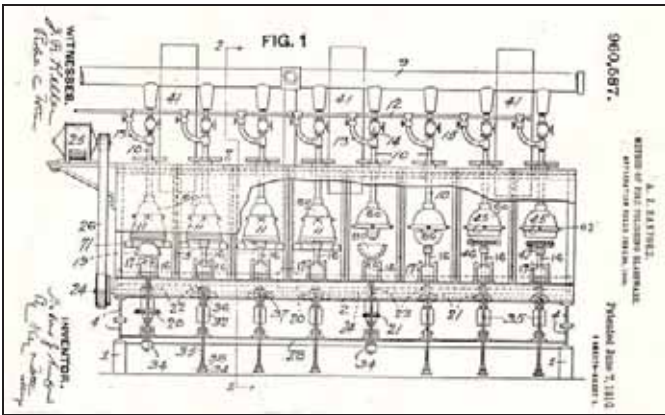

Patent 960,587 – Illustration 1

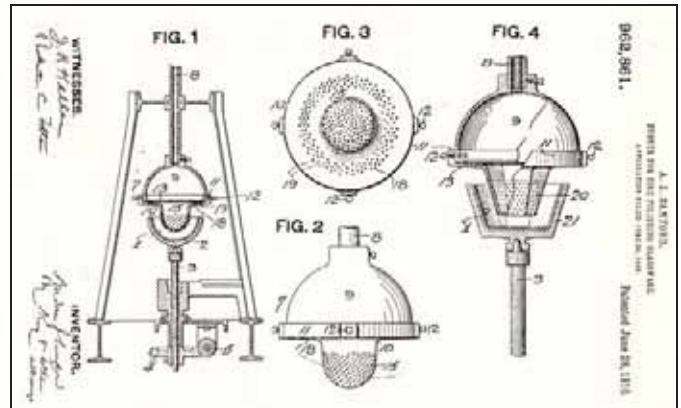

Patent 962,861

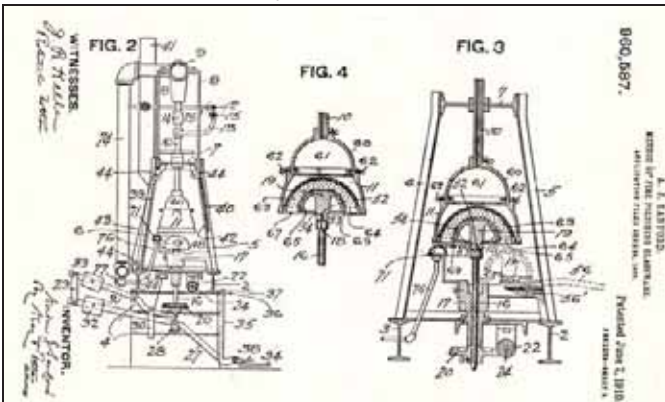

Patent 960,587 – Illustration 2

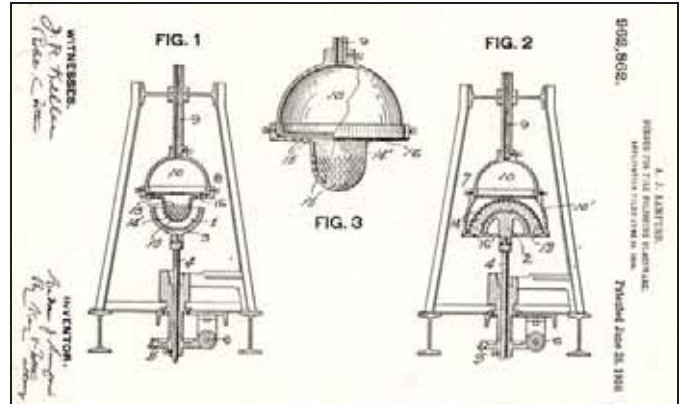

Patent 962,862

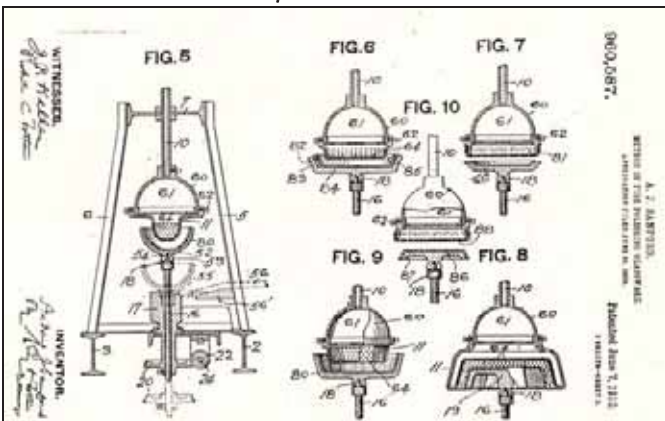

Patent 960,587 – Illustration 3

In part, patent No. 960,587 reads, “My invention relates to apparatus for fire polishing glass articles, its object being to provide for the proper fire polishing of both the interior and the exterior surfaces of articles of glassware, such as hollow bowls and the like, also including flat dishes with upwardly extending rim portions.

“It consists, generally stated, in supporting the article within a hollow burner and projecting from the hollow burner multitudinous flame jets distributed substantially evenly over the outer surface of the article to be fire polished.

“It also includes the finishing of bowl shaped articles by first projecting the flame jets against the interior thereof while supporting the article in a former conforming to the desired outer shape of the finished article.

“It also comprises the slow rotation of the article in fire polishing the exterior thereof so as to hold the same to the former on which it is supported, and the rapid rotation of the article when fire polishing the interior thereof so as to cause it to

The next four patents were all granted in June of 1910 and relate to fire-polishing glassware. The fire-polishing of glass was one thing that set the Heisey factory apart from its competitors, giving the final product a better finished look that caught the eye of the consumer. All of the patents were granted to Andrew J. Sanford of Newark, Ohio, and assigned to A.H. Heisey & Co, Inc, of Newark, Ohio.

Patent No. 960,587 was granted on June 7, 1910. On June 28, 1910, patents No. 962,861, 962,862, and 962,863 were granted.

conform in shape to the hollow former in which it is held."

Doing a little translating here we have a machine that will rapidly rotate a glass bowl while directing jet flames at the bowl for the purpose of fire-polishing the bowl. The exterior, rim, and interior of the bowl will all be subjected to this fire polishing. Patent 960,587 covers the basic machinery to support the bowl in the various steps of the fire-polishing process.

Patents 962,861 and 962,862 provide two different burners to go with the apparatus covered by patent 960,587. Patent 962,861 covers a "burner body having a cone or central projecting body portion adapted to enter within the article to be polished and having multitudinous jet openings for the escape of mixed gas and air on its bottom and side faces to project small flame jets ignited on the outside of the burner directly upon the interior of the article to be polished, as well as upon the top edge thereof, to secure the proper and even fire polishing of the interior of the article, and also the proper melting of the edges thereof to remove fins and cause proper rounding of such surfaces."

In patent 962,861 the "burner body has jet orifices of slit form formed in the body thereof for the escape of gas and air, such slit openings providing for the formation of longitudinal flame jets overlapping each other and so providing for the positive contact of the flame jets with the entire surface of the article to be polished. It also includes the combination therewith of means for rotation the article so as to expose its entire surface to contact with such longitudinally extending jet flames..."

The final patent in this series, No. 962,863, deals with the method of support for the article to be fire polished within the general framework of the previous patents. It also provides for control of the gas and air used in the process. The exact specifications run for over five pages in great detail so I will not go into all that here.

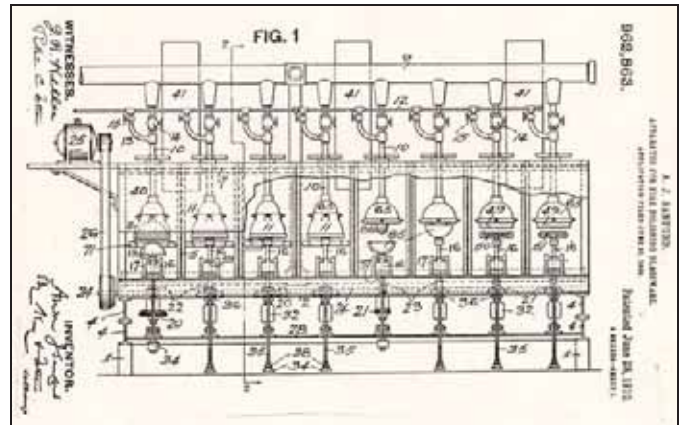

Patent 962,863 – Illustration 1

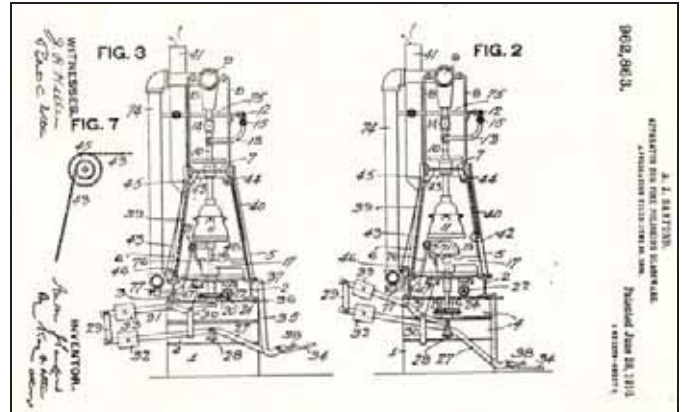

Patent 962,863 – Illustration 2

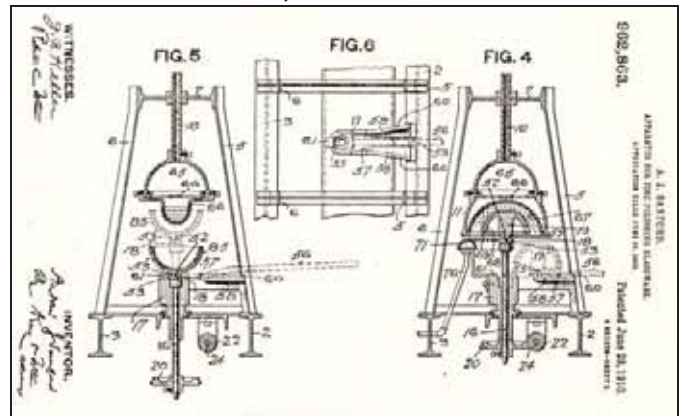

Patent 962,863 – Illustration 3

These inventions provide the other part of the Heisey glass making story. They show how the company came up with ways to make their products better through the way that the glass was made.

We will continue next month with additional utility patents that were granted to the company and its employees. One of the patents we will cover next month is for an innovation in crushed fruit design. ♦



Catalog #56 – Page 66, Vogel II – Page 163, Vogel IV – Page 139

379 URN

Joe Lokay

The 379 Urn pattern was introduced in late 1907. It was first offered in Heisey Price List #142, circa 1908. Production continued to about 1910 giving Urn a life span of around three years. A total of 53 items were offered in the pattern. The Urn pattern was named by early Heisey researcher Clarence Vogel.

There were 16 nappies in normal and shallow varieties of various sizes, a four piece table set, two styles of water pitchers, and two styles of tumblers. One tumbler was given the number 379 ½ to differentiate it from the other tumbler that was given number 379. There were three sizes of table salts, three styles of salt shakers (although the glass was the same in all three, only the tops varied), a cake plate, a syrup, two sizes of oils, molasses can, and a toothpick. There was a custard (punch cup) but no punch

bowl that was called a punch bowl. Everything was produced in crystal, there was no color being made during the production period for this pattern. Most of the 379 items were also offered with a gold decoration done by Heisey. The gold decoration was listed separately in Heisey Price List #42.

The Price List divides the items into two categories: (1) items with “cut tops” and (2) items with the “tops not cut.” Cut tops refers to the top rims having been ground and polished to give a perfectly flat and smooth edge or surface. Uncut tops are as they come out of the mold. The hot glass tends to slightly flow giving a slightly rounded edge.

There were 24 items offered in the “top cut” category and 51 items in the “not cut top” category. A total of 22 items were duplicated on both lists.



Catalog # 56 – Page 67, Vogel IV – Page 140



Catalog #56 – Page 65, Vogel IV – Page 141
Heisey News May 2009



Catalog #56 – Page 68, Vogel IV – Page 142

Urn is a colonial style design with vertical panels around the body of the item. The panels vary in number from 6 to 12 depending on the piece. There are three sets of closely spaced, raised bands that go completely around the body. Depending on which piece, there may be 1, 2, or 3 sets of closely spaced bands. For example, the nappy has three sets of bands: one set forms the top, a second set forms the base, and a third set is about 1/3 of the way up from the bottom. The toothpick has three sets of band, the custard has only two, and the finger bowl has only one. Where applicable, the bottom of a piece has the typical Heisey star.

I want to talk about a few of the pieces of this pattern. This is a transitional pattern in the serving of syrup/molasses. It has the last of the traditional large molasses cans with the domed tops that Heisey developed. It also has the first of the smaller syrups with the metal flip tops to be made by Heisey. In this case, the top is a flat lid with a small thumb tab that attached to the bottom just over the handle. It is rare now to see this syrup with its original metal lid. Heisey

would soon develop the more common lid that we see on later syrups that snaps onto the top.

Another interesting piece is one that never appeared in any of the Heisey catalogs. It is unusual enough to have a pattern that has three salt dishes (called large table, small table, and individual in the catalog), but there is another piece of about the same size that occasionally makes an appearance although the piece only has six sides whereas the salts have eight. It has a base about the same size as the small table and a top a little smaller than the large table. This results in a piece that is taller than any of the other salts and has a definite flare to it. The only pieces that appears on the "cut tops" list and does not appear on the "not cut top" list are a small salted almond and a large salted almond. It is easy to think of this unknown piece as the large salted almond. But that just raises the question of what the small salted almond might be because no other small piece has shown up. Could the small salted almond just be one of the salts (possibly the small table)? See page 17 for a picture of three of these pieces.

I mentioned above that there was no punch bowl in the pattern that was called a punch bowl. Instead we have two footed orange bowls, one 14" shallow and one 13" flared. The descriptions of these items are not elaborated upon, but one collector has assured me that these are actually two piece items with separate bases. Obviously, these would work perfectly as punch bowls for the pattern.

Finally, it is interesting to note that the hotel sugar came both with a lid and without a lid. The table sugar has a lid that sits on a ledge just below the top rim of the piece. I would assume that the hotel sugar with lid would have a similar ledge. I know of no other creamer that goes with two different sugar bowls that Heisey made. There is a ½ gallon jug with cover also listed in this pattern. There is not a catalog picture of this cover. One could assume that it is designed to look like the covers of the sugar bowls in which case the jug would have been made with a ledge for the lid to rest on. I have never seen an Urn jug with a lid.

Urn is a truly beautiful pattern that plays off of the simplicity of the design. Pieces in the pattern seldom reach the marketplace today. Consider yourself lucky to own just a single piece of this pattern.

Production of 379 Urn

Items that were produced both "tops not cut" and "cut tops"

1. spoon *
2. cream)
3. sugar and cover *
4. butter and cover *
5. nappy, 4" *
6. nappy, 4 ½" *
7. nappy, 5" *
8. nappy, 6" *
9. nappy, 7" *
10. nappy, 8" *
11. nappy, 9" *
12. nappy, 10" *
13. nappy, 4" ½", shallow
14. nappy, 5", shallow
15. nappy, 6", shallow
16. nappy, 7", shallow

17. nappy, 8", shallo
18. nappy, 9", shallow
19. nappy, 10", shallow
20. nappy, 11", shallow
21. salver, 10"
22. jug, ½ gal *
23. jug, ½ gal with cover
24. tankard, ½ gal *
25. water bottle *
26. toothpick *
27. salt, individual *
28. salt, small table *
29. salt, large table *
30. sugar, hotel *
31. sugar, hotel with cover *
32. cream, hotel *
33. goblet, 8 ½ oz
34. tumbler, 7 oz
35. tumbler, 8 oz (379 ½)
36. egg cup, footed, 5 oz.
37. sherbet, footed, 4 oz
38. custard (punch cup), 4 ½ oz.
39. salt shaker, no. 1, silver plated top
40. salt shaker, no. 2, spun nickel top
41. salt shaker, no. 3, sanitary top
42. oil, 4 oz, pressed or cut stopper
43. oil, 6 oz, pressed or cut stopper
44. syrup, sanitary, 7 oz
45. molasses, 13 oz, O.K. or nickel top
46. finger bowl
47. oyster cocktail, 2 piece
48. orange bowl, 12"
49. orange bowl, footed, 12"
50. orange bowl, footed, flared, 13"
51. orange bowl, footed, shallow, 14"

Items listed with "cut tops" but not on list "not cut tops"

52. salted almond, small
53. salted almond, large

References

1. Heisey Price List #142 (1908)
2. Heisey Catalog #56 (1909)
3. Heisey Price List #144 (1909)
4. Heisey News, March 1975, Pattern #379
5. Heisey News, October 1976, #379 Tumbler
6. Heisey News, March 1981, Toothpick
7. Heisey News, May 1984, Little Things
8. Heisey News, July 1986, Chronology 1904-1909
9. Vogel Book II, page 163 and Vogel Book IV, pages 139-142 ♦

BENEFIT AUCTION WRAP-UP

Dave Spahr, Auction Chair

Those who attended the 36th Annual Benefit auction had a great time - or so they said! Our two-day auction was held at the GMP Local #244 Union Hall on 350 Hudson Ave in Newark on Friday-Saturday, April 17-18. This is the second year using this great site. Our auction was well attended - approximately 120 guests and members each day and we had 11 absentee bidders. We had 936 lots of glass available from 35 consignors. We again heard many great comments about the glass we had again this year - our consignors sent in nice clean glass and we only had to reject a few unsuitable pieces. This year we had the preview on Friday, April 17, from 2:00 p.m. to 4:00 p.m. with the auction starting at 4:00 p.m. by auctioneer Craig Connelly. On Saturday, we opened the doors at 8:30 a.m., had our HCA Membership Meeting chaired by President Bryan Baker at 9:00 a.m., and started our auction at 9:30 a.m.

How did we do financially? At press time, we have only preliminary numbers. We grossed over \$63,545 and after consignors and expenses are paid, we estimate we will net somewhere around \$15,250. We had a budget estimate of \$13,800. With the economy the way it is affecting us all, I feel we did very well. FYI, last year we grossed \$56,415 and netted \$13,371 with our budget being \$14,000.

I want to publicly thank, on behalf of the HCA Board of Directors and Staff, the forty-four volunteers who worked with us starting in January identifying, cataloging, and repacking the glass and before, during, and after the auction! You make this event a success and HCA's largest fund-raiser. I have listed those who helped in a separate block. If you helped and are not listed, I apologize.

I would like to give special thanks to several individuals: Joe Harner, president of the Dayton Study Club and Dick Marsh, Buckeye Club president, both who helped me in all phases of the auction and did all the little things which need doing with little fanfare; to Board member Karen Taylo who ran the clerk's office and effectively and efficiently ran the computer auction program, and finally to Russ Reopell, who put our auction catalog on the HCA website.

A hardy thank you must also go to Craig Connelly, Auctioneer, and his three cohorts Jeff Baird, Tim Hughes, and Gary Babcock. They sold our glass and kept us in stitches! Concessionaire extraordinaire Gerry Dush and his gang again served the world's best pies and other food, and GMP Local #244's own Jerry West did everything he could to provide us great facilities and went the "extra mile" to make our auction a success. Lastly, thanks to the Dayton Heisey Collectors Club who, as always, worked diligently from January helping in all phases to make this auction a success!

Finally, I would like to thank all the consignors who consigned and donated glass to HCA and to all the auction attendees and absentee bidders who purchased that wonderful Heisey Glass. You make it all possible. See all of you at the Convention in June - until then, Happy Heisey Hunting!! ♦

AUCTION VOLUNTEERS

PHIL & SALLY ABRAMS
BRYAN BAKER
BARBARA BARTLETT
CHARLENE BOWMAN
JIM & KAREN CLARK
CAROLYN CROZIER
CHRIS DOYLE
SID & MARY EDWARDS
TOM FILES
CATHY HADAWAY
JOE HARNER
SALLY HOWARTH
CHUCK & AMY JO JONES
RON KEENER
DAN & SUE KILGORE
BOB & MARY KREIMER
SIBYL LAVENGOOD
ROBERT LOCH
WALTER LUDWIG
DICK & GINNY MARSH
JACK METCALF
DON & PAT MOORE
SHARON ORIENTER
MAC OTTEN
KEN & JUDY RHOADS
DICK & MARILYN SMITH
KATHY SMITH
DAVE & MARY ANN SPAHR
MERRY SPAHR
ERIC TANKESLEY-CLARKE
KAREN TAYLO
CHARLIE WADE

2009 BENEFIT AUCTION RESULTS

1	125	52	25	103	40	154	65	205	25	256	170	307	20	358	30	409	90
2	20	53	20	104	27.5	155	70	206	25	257	500	308	45	359	80	410	180
3	10	54	25	105	30	156	130	207	30	258	25	309	15	360	15	411	125
4	170	55	180	106	25	157	25	208	40	259	200	310	22.5	361	250	412	225
5	10	56	170	107	15	158	25	209	10	260	75	311	12.5	362	25	413	50
6	50	57	20	108	20	159	20	210	25	261	55	312	45	363	5	414	40
7	20	58	50	109	20	160	15	211	20	262	700	313	45	364	15	415	150
8	50	59	30	110	50	161	10	212	45	263	110	314	25	365	20	416	225
9	35	60	75	111	95	162	15	213	25	264	35	315	20	366	10	417	475
10	65	61	170	112	95	163	25	214	45	265	110	316	240	367	45	418	180
11	20	62	225	113	70	164	25	215	15	266	150	317	40	368	50	419	95
12	40	63	60	114	60	165	20	216	80	267	55	318	45	369	90	420	75
13	30	64	65	115	15	166	10	217	20	268	10	319	45	370	135	421	275
14	25	65	45	116	25	167	115	218	10	269	40	320	24	371	55	422	195
15	10	66	70	117	25	168	30	219	35	270	10	321	15	372	10	423	60
16	35	67	35	118	30	169	20	220	20	271	10	322	50	373	75	424	125
17	25	68	0	119	100	170	55	221	25	272	10	323	10	374	20	425	55
18	20	69	200	120	25	171	20	222	75	273	20	324	5	375	110	426	340
19	350	70	30	121	35	172	5	223	175	274	40	325	80	376	75	427	75
20	10	71	35	122	10	173	25	224	35	275	60	326	35	377	15	428	35
21	20	72	45	123	1100	174	20	225	20	276	100	327	55	378	95	429	100
22	20	73	10	124	25	175	115	226	25	277	155	328	75	379	10	430	80
23	20	74	35	125	10	176	30	227	20	278	110	329	45	380	40	431	65
24	35	75	20	126	65	177	10	228	45	279	30	330	25	381	15	432	35
25	65	76	45	127	110	178	55	229	45	280	25	331	5	382	12.5	433	35
26	70	77	15	128	50	179	80	230	35	281	75	332	10	383	65	434	55
27	70	78	25	129	25	180	40	231	60	282	110	333	10	384	60	435	20
28	110	79	35	130	45	181	130	232	55	283	50	334	5	385	115	436	10
29	75	80	15	131	12.5	182	55	233	210	284	90	335	5	386	85	437	55
30	55	81	30	132	40	183	65	234	235	285	25	336	20	387	25	438	25
31	65	82	40	133	50	184	35	235	350	286	140	337	5	388	25	439	10
32	35	83	25	134	30	185	65	236	65	287	60	338	7.5	389	15	440	25
33	25	84	15	135	35	186	40	237	150	288	75	339	20	390	200	441	45
34	20	85	25	136	90	187	20	238	210	289	75	340	20	391	50	442	65
35	65	86	27.5	137	35	188	20	239	55	290	425	341	5	392	20	443	20
36	90	87	30	138	60	189	55	240	27.5	291	70	342	20	393	35	444	35
37	45	88	15	139	15	190	15	241	130	292	125	343	90	394	45	445	25
38	35	89	25	140	65	191	10	242	120	293	75	344	140	395	30	446	30
39	40	90	22.5	141	15	192	55	243	350	294	50	345	130	396	20	447	10
40	50	91	15	142	2200	193	15	244	150	295	95	346	120	397	15	448	10
41	35	92	20	143	2200	194	35	245	85	296	35	347	120	398	25	449	30
42	35	93	15	144	150	195	25	246	85	297	35	348	0	399	25	450	50
43	45	94	25	145	35	196	30	247	400	298	40	349	20	400	35	451	25
44	75	95	30	146	35	197	30	248	325	299	10	350	65	401	35	452	10
45	25	96	15	147	35	198	35	249	35	300	55	351	60	402	30	453	15
46	85	97	22.5	148	65	199	20	250	110	301	15	352	45	403	2600	454	30
47	30	98	50	149	65	200	10	251	270	302	15	353	90	404	325	455	20
48	30	99	35	150	15	201	35	252	75	303	25	354	30	405	275	456	750
49	20	100	25	151	55	202	15	253	100	304	60	355	60	406	300	457	185
50	10	101	40	152	50	203	22.5	254	300	305	15	356	30	407	55	458	10
51	50	102	40	153	120	204	15	255	600	306	25	357	20	408	350	459	30

460	15	513	60	566	50	619	120	672	15	725	20	778	5	838	10	937	15
461	120	514	70	567	22.5	620	650	673	25	726	20	779	30	839	10	938	20
462	35	515	45	568	75	621	10	674	65	727	20	780	15	840	15	939	20
463	100	516	115	569	75	622	45	675	55	728	10	781	5	841	20	940	5
464	25	517	55	570	50	623	40	676	620	729	50	782	17.5	842	15	941	15
465	15	518	70	571	45	624	50	677	50	730	10	783	40	843	10	942	20
466	45	519	50	572	50	625	20	678	65	731	20	784	20	844	12.5	943	250
467	60	520	50	573	45	626	15	679	45	732	60	785	20	845	30	944	95
468	40	521	180	574	80	627	310	680	75	733	75	786	25	846	17.5	945	5
469	45	522	50	575	5	628	75	681	55	734	60	787	25	847	10	946	80
470	15	523	95	576	35	629	45	682	30	735	55	788	5	848	32.5	947	20
471	25	524	65	577	5	630	75	683	55	736	10	789	30	849	12.5	948	55
472	20	525	525	578	17.5	631	175	684	35	737	15	790	7.5	850	12.5	949	10
473	25	526	375	579	25	632	20	685	20	738	25	791	10	851	25	950	20
474	65	527	230	580	20	633	35	686	15	739	12.5	792	55	852	15	950A	35
475	15	528	350	581	40	634	55	687	40	740	20	800	15	853	15	950B	115
476	80	529	60	582	20	635	20	688	45	741	15	801	22.5	900	22.5	951	25
477	25	530	35	583	15	636	35	689	45	742	32.5	802	10	901	65	952	55
478	5	531	25	584	15	637	10	690	5	743	95	803	5	902	25	953	135
479	75	532	5	585	15	638	30	691	20	744	25	804	5	903	55	954	55
480	25	533	20	586	10	639	85	692	30	745	55	805	5	904	60	955	35
481	30	534	10	587	12.5	640	35	693	20	746	25	806	5	905	25	956	30
482	10	535	30	588	17.5	641	10	694	45	747	40	807	12.5	906	35	957	85
483	15	536	7.5	589	17.5	642	40	695	12.5	748	35	808	5	907	70	958	45
484	5	537	30	590	20	643	15	696	30	749	35	809	5	908	17.5	959	60
485	50	538	10	591	20	644	115	697	7.5	750	30	810	5	909	90	960	50
486	15	539	10	592	25	645	30	698	35	751	65	811	7.5	910	75	961	25
487	40	540	10	593	8	646	50	699	7.5	752	20	812	7.5	911	290	962	30
488	25	541	10	594	10	647	60	700	35	753	10	813	7.5	912	50	963	10
489	20	542	7.5	595	5	648	85	701	20	754	45	814	5	913	25	964	55
490	30	543	12.5	596	20	649	150	702	35	755	55	815	7.5	914	85	965	15
491	25	544	22.5	597	60	650	35	703	35	756	10	816	15	915	10	966	45
492	45	545	5	598	10	651	40	704	45	757	80	817	5	916	80	967	10
493	15	546	10	599	5	652	20	705	25	758	15	818	7.5	917	55	968	20
494	25	547	5	600	7.5	653	45	706	45	759	75	819	22.5	918	32.5	969	20
495	550	548	5	601	10	654	50	707	50	760	55	820	80	919	120	970	20
496	95	549	65	602	20	655	20	708	15	761	5	821	50	920	55	971	7.5
497	125	550	7.5	603	80	656	25	709	20	762	12.5	822	20	921	5	972	30
498	225	551	12.5	604	15	657	15	710	10	763	12.5	823	10	922	47.5	973	55
499	350	552	12.5	605	7.5	658	10	711	10	764	40	824	22.5	923	5	974	375
500	90	553	5	606	10	659	60	712	30	765	30	825	25	924	20	975	10
501	65	554	5	607	5	660	15	713	50	766	10	826	22.5	925	35	976	45
502	35	555	5	608	40	661	30	714	7.5	767	25	827	17.5	926	25	977	200
503	475	556	7.5	609	15	662	20	715	50	768	22.5	828	17.5	927	25	978	160
504	300	557	20	610	10	663	20	716	25	769	12.5	829	20	928	20	979	10
505	25	558	375	611	30	664	45	717	30	770	45	830	5	929	30	980	75
506	100	559	180	612	20	665	35	718	40	771	5	831	35	930	35	981	85
507	120	560	30	613	250	666	30	719	17.5	772	27.5	832	22.5	931	20	982	40
508	25	561	190	614	30	667	50	720	25	773	45	833	70	932	25	983	80
509	200	562	35	615	160	668	15	721	10	774	12.5	834	100	933	30	984	25
510	100	563	60	616	40	669	15	722	20	775	12.5	835	130	934	10	985	275
511	80	564	50	617	7.5	670	15	723	15	776	25	836	130	935	240	986	150
512	140	565	12.5	618	1850	671	15	724	20	777	10	837	32.5	936	17.5	987	10

2009 CANDIDATES FOR THE HCA BOARD OF DIRECTORS

Following is the slate of candidates as presented at the HCA general membership meeting Saturday, April 18. A total of three will be elected. **Absentee ballots must be returned to the Museum by noon, June 18 in order to be processed for the election.** (If requesting a ballot by mail, please allow enough time to have it returned to you and for you to mail it in.) Ballots can be requested **NOW**. Please see the March 2009 Heisey News for procedures to request an absentee ballot.

Charlene Bowman



Charlene is a graduate of Miami University, Oxford, Ohio, and spent a number of years in retail management.

She and her late husband Carl began collecting Heisey in the late 70s. The first piece, a "marked" cream and sugar, evolved to an extensive collection of Heisey candlesticks, toothpicks, barware and whatever else caught their fancy. They accumulated enough to share and began as dealers around 1986 on the square in Newark. They soon embarked on the glass show circuit, traveling all over the Eastern United States. Charlene continues to enjoy collecting and selling Heisey and other elegant glass.

She has been active in the Dayton Collectors Club since 1986, serving over the years as President and Secretary and currently holds the office of Vice President, in charge of programs.

National activities include membership in HCA since 1982. During the 1980s and 90s she helped organize and implement the Silent Auction and Swap Meet sponsored by Dayton

Collectors Club. She has catalogued and set up for Benefit and Select Auctions, decorated the Museum, helped at Open House, and currently serves as 2009 Convention Ambassador in charge of Special Banquet Auction.

Her goals include:

- ◇ Cultivating the interest of young people in the collecting and studying of Heisey glass, as well as keeping present members interested and active.
- ◇ Improving communication between the HCA Board of Directors and the Membership.
- ◇ Taking steps to maintain and improve the long term health of HCA

Robert Kreimer



I was born in Washington, DC, and raised in Lakeland, FL. I received a BS in Business Administration from the University of Florida in 1960. I served 27 years in the Supply Corps of the US Navy, spending most of my service in

major procurement of ships and submarines. I retired as a captain in 1987.

Mary and I went to an antique show in about 1989 and stopped in a booth full of beautiful glass. When we asked what made the glass so shiny, we really got an earful! The dealer was Dick Schwan! And so it began. When the collection became completely unmanageable, Mary and I became dealers, currently selling at 10-12 shows a year. Yes, we are often asked about how it happens that our glass is so shiny. You all know the answer, "It's Heisey!"

We joined the Florida Gulf Coast Heisey Club when we moved back to Florida in 1996. I have

served two terms as president of the club and have done numerous programs. We have also done presentations about Heisey glassware at several depression glass clubs in Florida.

I have decided to raise the level of my involvement by running for the Board of Directors of HCA. I appreciate your support.

Karen Taylo

I have never been one to blame my parents for the things that have occurred in my adult life, but they did get me hooked on collecting Heisey. They began collecting in 1995



and I started shortly thereafter. To say that I am an avid collector would be an understatement. I not only enjoy collecting the glass, I enjoy everything associated with Heisey including magazine ads, original catalogs, etc. I joined HCA shortly after starting to collect and have been an active member of the North Carolina Heisey Study Group. I have served as Secretary of the Group for a number of years and also publish our newsletter, Heisey Hi-Lites. I even created a web site for NCHSG. Many of you might know me from the registration desk at the HCA Convention each June.....I'm the one with the long hair!

I am a graduate of Vanderbilt University where I earned my Bachelor of Science in Nursing degree. I have worked in health care management for over 20 years as a nurse manager, an administrator and a nurse consultant.

As a current board member seeking reelection, I would like to continue to work to strengthen HCA's membership and to assure the financial viability of the Museum. Your support would be greatly appreciated! ♦

2009 BENEFIT AUCTION PICTURES



Could the Real Vanna Have Done Any Better?



The Auctioneers Looking for Bidders



A Behind the Scenes Look at the Auction



Returning the Glass to the Pickup Area

2009 FIFTH ANNUAL HEISEY SELECT AUCTION

Dave Spahr

In April we announced our Fifth Annual Heisey Select Auction. We are holding it again as an activity at our annual Percy and Vivian Moore Weekend events here in Newark. Thanks to the great support you all have given for this relatively new event and fall fund-raiser for the HCA Museum. As a reminder, please place this date on your calendar and "must not miss" list - **October 3, 2009**. This article is a reminder to select the glass you want to submit for consideration by the committee.

A key date is coming up this month - the deadline for submitting your glass lists for us to consider to select glass for this auction is **MAY 18, 2009**. A blank list for you to use is on page 18 of this newsletter. Please note the blank list contains space for twenty lots - each member is allowed to submit **forty lots** for the committee to select from. Remember, this auction benefits your association. Please consider selecting a special piece of Heisey for a donation to be auctioned off - 100% of the sale price would then go to support HCA and the Museum. Donations don't count towards your 40 lot limit. We hope like last year, that Study Clubs will consider donating glass for this auction - a great project for them! If you do not belong to a study club this is a great opportunity for you to support OUR Museum by donating a piece of Heisey. And you don't have to consign glass to make a donation! To continue our tradition for this event, we are maintaining our low consignment fee of 20% with a minimum consignment fee of \$5. This means anything that sells for \$25 or less the consignment fee will be \$5.

As you prepare your lists, please make them as descriptive as possible since the committee will be using them to select glass for the auction. In particular please check for damage - **we are selecting only undamaged glass** for this special

auction. The committee's target is to have an auction with two hundred (200) lots. How can you get your glass selected? Here are some clues. Consideration will be given to include diversity in color, etchings, cuttings, and patterns. We want no duplicates and we would like expensive and not so expensive glass for both the novice and experienced collector. As mentioned earlier, we will not select damaged glass.

The Select committee will be busy after May 19 and contact you on or about June 1 to let you know the glass it has selected. Hopefully, you will be able to bring your glass to Newark and drop it off at the Museum when you come to the Convention on June 17-20. The auction will be held in the lower level in the Museum in the activity center.

This event has been a success for consignors and those purchasing the wonderful Heisey glass. Plan on attending and participating in this auction for the benefit of your Museum. If you have any questions, please e-mail or call Dave Spahr, masdgs@aol.com or (937)-372-7166. Happy Heisey Hunting! ♦



379 Urn Master Salt, Large Salted Almond (?),
Individual Salt
(See Article Pages 8-11)

**HCA WELCOMES
NEW MEMBERS
FOR
March 2009**

Claudie E. Lind, WA

2009 SELECT AUCTION GLASS LIST

FOR THE BENEFIT OF HCA

Consignor/ Owner: _____

Address: _____

Daytime Phone: (____)-____-____ Fax or E-mail _____

SEND TO: Select Auction, c/o HCA, 169 W. Church St., Newark, OH 43055

DEADLINE: List must be received by May 18, 2009

Lot #	Qty	Pattern #/ Name	Description	Cut/Etch	Color	H	Damage
1							
2							
3							
4							
5							
6							
7							
8							
9							
10							
11							
12							
13							
14							
15							
16							
17							
18							
19							
20							

**Please put a "D" beside the lot number if the lot is to be donated to HCA.
Each consignor may submit up to 40 lots.**

2009 HCA CONVENTION – REGISTER NOW!

Judy Rhoads & Mary Ann Spahr, Co-Chairs

Time is running out! The 2009 Heisey Convention is only a few weeks away. Be sure to get your reservations in NOW! The registration deadline is June 4, 2009. We don't want anyone to miss the fun! Forms are on page 21 of this Heisey News.

Judy and I are having such fun planning and coordinating your 2009 HCA Convention. We are trying to involve Heisey talent from all over the country! If you have been missed and are interesting in helping, please contact us at masxenia@aol.com or at kjrhoads@aol.com!!

Since January, we've been highlighting special convention events ... and we're not done yet! Check out the following information for the Historic Heisey Driving Tour, the Former Employees Reunion, the Special Auction, and the Flea Market on the Square activities.

The Historic Heisey Driving Tour, Dick Marsh and Tom Heisey

Dick and Tom and some other folks have been developing a driving tour of Newark that leads to historic Heisey sites around town. Dick says that it's a driving tour that includes the old plant site and former Heisey family homes. As these are private homes, this will be a viewing of the homes only from the outside. The at-your-leisure self-guided tour begins at our Museum. Tour directions will be with your packets. We are excited about it. We hope you find time during Convention to take the tour and get the feel for this interesting city where beautiful glass was made.

Heisey History Makers, Tom and Kathy Files

They made it – we collect it! It's hard to believe but the Heisey factory has been closed for over

50 years! As you pencil in your activities for the 2009 Convention, please plan on attending the former employees reunion at 1 p.m. on Friday in the Museum Hospitality Room.

You will have the good fortune to visit with former Heisey employees and other Convention attendees. It's not only an opportunity to learn some "insider information" but also a time to say "Thank You" to some of the people who made the glass we love and collect. Stop by. You have plenty of time to visit and refuel on complimentary snacks and drinks before you head out for the next scheduled event – the 3 p.m. seminar on Heisey etchings.

Friday Night Excitement: The Special Auction, Charlene Bowman

Convention is fast approaching and the excitement is building. This Special Auction, held at our annual HCA Banquet on Friday evening, is always a highlight ... and this year will be no exception! There will be "wonderful" Heisey treasures for you to acquire (hint: Plantation, candleholders, silhouette etches, a glass working tool, and many other surprises). We will have items of interest to the advanced collector as well as the novice. The auction is a way to make a donation to the Museum and also take home a Heisey treasure.

If your club would like to help by donating an item to be auctioned, feel free to contact me at twoclbs@aol.com. I'll get donation info out to you post haste!!

Flea Market on the Square, Jeff Morrow

This event is a reprise of a long ago "Heisey Hunters" tradition. Relive the excitement on the Square in downtown Newark on Saturday, June 20, 8:00 a.m. – noon. Dealers may set up as early as 7:00 a.m., and Heisey Hunters may begin shopping at 8:00 a.m.! See our ad on page 25 of this Heisey News. Questions? Please contact Jeff at jmorrow64@comcast.net.

SEE YOU AT THE CONVENTION !!! ♦



38th Annual Convention
HEISEY COLLECTORS OF AMERICA, INC.
 JUNE 17-20, 2009

"Artistry in Glass: the Heisey Etchings"

SCHEDULE of EVENTS

Event	Time	Location
WEDNESDAY, June 17		
Registration Pickup	2:00 - 5:00 p.m.	Museum
<i>"Tally Ho"</i> ...and off we go ... Welcome BBQ	5:30 p.m.	{ Rotary Park Sharon Valley Rd Newark
Museum "Heisingo"	8:00 p.m.	
THURSDAY, June 18		
Registration Pickup	10:00 – Noon	Museum
<i>"You, Me, Us!"</i> Study Club Representatives meeting	10:00 - 11:00 a.m.	Founders Hall Auditorium
Glass Show tickets sales begin	11:30 a.m.	Adena Hall, OSUN/COTC
Show Preview (<i>Convention Registrants Only</i>)	Noon - 1:00 p.m.	Adena Hall
Glass Show open – General Admission	1:00 - 7:00 p.m.	Adena Hall
Registration Pickup	1:00 - 4:00 p.m.	Adena Hall
Seminar	3:00 p.m.	Adena Hall
Glass Identification Session / Show & Tell	8:00 p.m.	Founders Hall Auditorium
FRIDAY, June 19		
<i>"Good Morning"</i> Annual General Membership Mtg	8:30 a.m.	Founders Hall Auditorium
Glass Show open – General Admission	Noon - 5:00 p.m.	Adena Hall
Former Employees Reunion	1:00 - 2:00 p.m.	Museum
Seminar	3:00 p.m.	Adena Hall
<i>"Tavern"</i> Cocktails (cash bar)	6:00 - 7:00 p.m.	{ The Crystal Ballroom 29 W Church St Downtown Newark
<i>"Classic"</i> Heisey Banquet / Special Auction	7:00 p.m.	
SATURDAY, June 20		
Flea Market on the Square	8:00 a.m. – Noon	Courthouse Square Downtown Newark
Glass Show open – FREE ADMISSION	Noon – 5:00 p.m.	Adena Hall

OPEN HOUSE

The National Heisey Glass Museum
 Tuesday – Saturday, June 16-20, 10:00 a.m.- 4:00 p.m.
 Sunday, June 21, 1:00-4:00 p.m.

Hospitality in Multipurpose Room, Thursday & Friday, 10:00 a.m. – 4:00 p.m.



HCA CONVENTION 2009 REGISTRATION FORM

REGISTERING IS EASY !

Forms are available in your Heisey News and online at www.HeiseyMuseum.org

1) **Mail** forms to Convention Registration, 169 W Church St, Newark OH 43055; 2) **Deliver** forms directly to the Museum; 3) **Phone** in registration information at 740-345-2932; or 4) **Fax** forms to 740-345-9638 !

- ◇ **Registration deadline Thursday, June 4**, for all food events. Sorry, **no registration refunds after June 8** when final counts are taken!
- ◇ If you are not registering the same people for all events, or individuals are from different locations, please fill out a separate form for each person.
- ◇ If you want notice of confirmation, you must include a SASE or provide an E-mail address below.

Please print each name as it should appear on their badge:

Name(s): _____

Address: _____

City / State / Zip _____

Phone: (____) _____ E-mail: _____

Check here to receive E-mail confirmation of your registration

IS THIS YOUR FIRST HCA CONVENTION? _____ WOULD YOU LIKE A MENTOR? _____
 OLD TIMERS, PLEASE APPROXIMATE the YEAR OF YOUR FIRST CONVENTION ! _____

PAYMENT: Cash Check
 MasterCard Visa # _____ exp _____

Event	How Many?	Cost	Subtotal
Registration Fee (Deadline Thursday, June 4)	_____ X	\$25	= _____
*Welcome BBQ, Wednesday, 5:30 p.m. <i>Pulled Pork, BBQ Beef, Sweet Corn Bake, Baked Beans, Tossed Salad, Potato Salad, Watermelon, Rolls, Cobbler</i>	_____ X	\$12	= _____
Thursday Seminar: "The Heisey Etchings"	_____	FREE	
*Glass ID Session / Show & Tell	_____	FREE	
Annual Meeting, <i>Open to all HCA Members</i>	_____	FREE	
*Former Employees Reunion	_____	FREE	
Friday Seminar: "The Heisey Etchings"	_____	FREE	
*Heisey Banquet / Auction, Friday, 6:00 p.m. <i>ROAST BEEF AU JUS, CHICKEN CORDON BLEU, TOSSED SALAD, ROASTED RED POTATOES, VEGETABLE MEDLEY, DESSERT</i>	_____ X	\$25	= _____
Flea Market on the Square	_____	FREE	
Hospitality Room, Thursday & Friday at Museum	_____	FREE	

**You must be registered to attend these events !*

TOTAL = \$ _____



HEISEY GLASS MUSEUM PLAYING CARDS

Edition 3 (green deck) of Heisey Glass Museum Playing Cards are now in. In addition, we have for sale a limited number of uncut sheets (21" x 25") which will be suitable for framing. This deck features the Heisey animals and animal related items. The full color pictures are stunning and will make a good learning tool as well as a nice gift for all of your glass collecting friends. We will ship as soon as available. Orders for Card Cases (Cobalt) and the Red deck may also be placed on this form.

Name _____
 Address _____
 City _____ State _____ Zip _____
 Phone and/or E-mail _____

I wish to order:	Total
_____ (number) Heisey Glass Museum Playing Cards (Green) @ \$10 each	_____
_____ (number) Heisey Glass Museum Playing Cards (Red) @ \$10 each	_____
Shipping per deck \$ 1.50 (can be picked up at Gift Shop)	_____
_____ (number) Uncut sheets of Heisey Playing Cards (Green) @ \$25 each	_____
_____ (number) Uncut sheets of Heisey Playing Cards (Red) @ \$25 each	_____
Shipping per uncut sheet @ \$5.00 each (can be picked up at Gift Shop)	_____
_____ (number) 1508 Card case in Cobalt @ \$24.95 each	_____
Shipping per card case @ \$6.00 each (can be picked up at Gift Shop)	_____
Grand Total (tax will be added when appropriate)	_____

Check # _____ Visa _____ Master Card _____
 Card Number _____ Exp _____

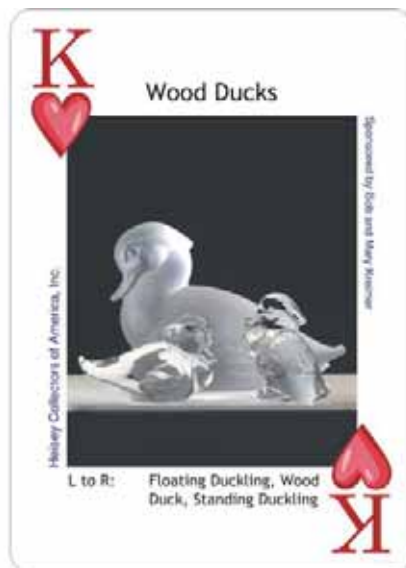
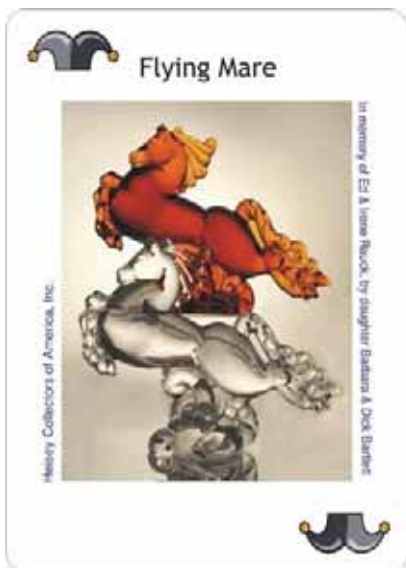

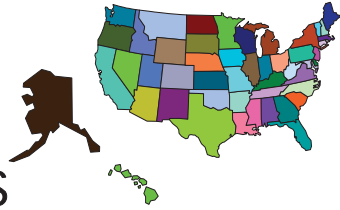

CLUB NOTES

Great Plains Heisey Club *Kathy Files*

Heisey and Kansas City BBQ – who could ask for anything more? OK, add some homemade pie a la mode. The first 2009 meeting of the Great Plains Heisey Club was at Jean Will's home in Leavenworth, KS, on April 4 with President John Mock presiding over a group of 14 members. (Postponed a week due to rain, freezing rain, sleet, snow, and wind on the previous Saturday -- ya gotta love weather in the Midwest). We missed some of our "snow birds" still in the South, Bucky who was ill, and the Camerons who were celebrating birthday # 2 for their twin grandchildren.

Special guest Buck Elliott brought a beautiful peachblow vase. Buck's wife had a link to the Heisey family tree and considerable family evidence linked the piece to possibly being produced experimentally in the Heisey factory. In any event, it was a beautiful, silky piece of glass made with an expensive process using gold. A rare sight for all to see.

Trudy Mock presented her "Martha Moments" showing Heisey featured in Country Living and Paula Deen magazines.

The program for the meeting was Heisey plates. Sounds simple but we had no idea Heisey made so many plates. Eric alone brought about 60 plates and other members chimed in with different styles, sizes, and colors. We had little plates, big plates, plates in most all the colors, plates with cuttings, etches, and carvings, plates with decorations – so many plates we had to bring out more display tables and start stacking the plates to save space. Some of these plates we had only seen in books – it was much more informative to see them in person and study the designs up close.

Since this was our first meeting since last November, members had a long winter to acquire Heisey for Show and Tell. Here's a few of the pieces shown: 393 Narrow Flute orange juice, 150 Banded Flute 3 pint jug with silver overlay, 1511 Toujours apple marmalade with extensive silver decoration, 493 cologne with cutting, 1567 Plantation candleblocks, 1425 Victorian 2 oz. bar, #12 salt and pepper, 1201 Fandango 8 oz. oil, 355 Bordeaux bon bonniere stem, two 1020 Phyllis cream and sugar sets with the same grey cutting (actually one cream

was the 1190 piece with the same cutting), Imperial Clydesdale in Salmon, 1413 Cathedral flared vase with 855 Fuchsia cutting, 5048 Rooster Head cocktail, 1170 Pleat and Panel compotier in Moongleam, 325 Pillows salt dip, 1112 Sparta footed sherbet, 310 Ring Band tumbler in Custard with decorative picture, 1614 Plume candlesticks, 305 Puntty and Diamond Point spoon, and other pieces I was drooling over and forgot to record.

We passed the Heisey hat (bowl) and held an auction to add some money to the treasury. One item sold was a hand-tooled step stool made by John Mock of wood from his father-in-law's barn. We'll sell most anything to raise money for HCA. ♦

Heisey Collectors Club of Michigan *Sue Kilgore*

Our first meeting to be held since our Christmas gathering was held at the home of Dan & Sue Kilgore in Kalamazoo. It was great to see everyone since all of our winter meetings were cancelled. We don't have to tell you what an unbelievable winter we had! The daffodils never looked so good.

We were encouraged to talk fast as many were traveling a great distance to see our MSU basketball team in the Final Four. Imagine – Heisey and basketball all in the same day!!

Our meeting was called to order by our president, Sue Kilgore. Present were Jean & Mary Parrett, Don & Betsy Hanna and their daughter-in-law Shirley Hanna, Rick VanMeer, Chuck & Diana Rose, and our club "friends", Larry & Ruth Ernest, Bart & Nancy Page, and John & Sheila Deming.

Our clubs new officers were elected and they are – Sue Kilgore, President, Dan Kilgore, Secretary and Diana Rose, Treasurer.

"Heisey sightings" were Paula Deen's magazine article on the Heisey Plantation as reported in the Heisey Newsletter. Also, in the Martha Stewart Living July 2008 magazine there was an article on glass covers for food (page 82). On the bottom shelf there is a Banded Flute butter and cover in the center of the photograph. Another covered butter appears on the top shelf that looks like it would be Heisey, but we cannot be sure.

A discussion about new members for our club was presented to our guests who were encouraged to join HCA and our Michigan club. Following our meeting, all three guest couples did join our club.

Fund-raising projects were presented. Selling flowers from Brecks starting with the benefit auction through the convention could be a huge fund-raiser for all of our club members. Folders were handed out and all were encouraged to sell to their local families and friends as well as any and all of the HCA members.

Mary Parrett is designing Heisey calendars with the help of Diana Rose. A 12 month calendar starting in July 2009 and running through June of 2010 was suggested and would include photos of etchings. Mary will have more information ready at the next meeting. Additional note cards are being considered with several suggestions of possible designs. We will keep everyone posted.

After the meeting, a table was set up to exhibit Spring Animals. Collectors can well imagine a display of all the bunnies, chicks and chickens. It was a great photo op!! ♦

Northwoods Heisey Club of Minnesota
Ann Moll

The Northwoods Heisey Club of Minnesota met on March 14, 2009, at the home of Bob and Bev Heise. Preceding the start of the meeting was a "Welcome Home" to our snowbirds, Marv and JoAnn Christenson, an introduction of our guest, Carolyn Lubke and a medical update of Virginia Johnson, plus Jerry and Marilyn Coleman.

After approving the minutes of the November 8, 2008, meeting and the treasurer's report, we continued a discussion of establishing a web site, and the display of Heisey at the Edina library. We are hopeful an article, written by Carole/Gordon Olsen about the Heisey Convention, will be published in the "The Old Times" newspaper.

Carole Olsen presented an informational program about etchings, with an emphasis on the kinds of etchings. Needle, pantograph and plate etchings were described. Some members brought samples of etchings. Marv showed examples of 445 Trojan, 447 Empress, 452 Ambassador, 449 Pompeii, 455 Titania, and 467 Tally Ho. Odell had a 459 Fisherman beer mug. Carole also presented each of us a reference booklet about etchings.

After enjoying some delicious treats served on Heisey glassware, we proceeded with our closing activity of sharing Heisey pieces. Marv was first with a cut compote of Heisey, with two separate markings. Odell presented a 5058 Goose stem sherry glass.

Our next meeting will be on May 2, 2009, at 1:00 p.m. at the home of the Olsens. There will be an election of officers, membership renewal of dues, our annual auction

of Heisey glass, plus a raffle of a Heisey piece, already donated by the Olsens. ♦

Heisey Collectors of Texas
Erma Hulslander

The Heisey Collectors of Texas headed west of Dallas in March, to Bedford, TX! Mike and Cindy, who live down near Houston, enjoyed seeing Candy & Greg's wonderful collection for the first time. When you go to a home that has soooo many cabinets full of Heisey, no one is able to see it all, even if we went once a year to Candy & Greg's!! Plus, they are always adding to their collection! We had 15 members present, who had a great day enjoying talking "Heisey"!

During our serious time at this meeting, we talked about HCA Convention coming up real soon! Sally reminded everyone that we would be having the HCA Benefit Auction at her home, on the 1st Saturday in May. She also noted the instructions on our "Wrapped and Unwrapped Auction."

Our Program was on "Heisey Cuttings." The Heisey Cutting Shop started around 1914. The Engravings are somewhat easier to find, than the Gray, Rock Crystal and Gray and Polished cuttings. Greg had many goblets with many cuttings; one very outstanding cut was 4055 Park Lane goblet with 863 Contessa cut, ca.1935. Some of the hard-to-find cuttings, that I remember seeing: 844 ½ Cromwell, 801 Wakiki, and 859 Cohasset. The 781 St. Anne was quite elaborate. St. Anne was the first cutting to reflect the influence of Emil Krall, according to our "Heisey Production Cutting" book. From 1933 to early 1940s The Heisey Company enjoyed Emil Krall's elaborate and exquisite work. Thanks, Greg, for a very interesting program, enjoyed by all of us lovers of "Heisey Cuttings."

The Crystolite people George & Barbara, brought a 1503 Crystolite ball vase, a small punch bowl, and a sweet pea vase for Show & Tell. Also, they were educating us on the difference between Duncan's Radiance pattern and Heisey Crystolite, so similar!!

Show & Tell went on with Mike & Cindy, who love the animals, as do most of us! How many of us have the Amber Doe Head bookend or the Amber Elephant, both marked with the Diamond H? These are Rare whether they are Heisey Amber, or Heisey by Imperial Amber, just beautiful! Topping that off, was the Bull also marked with the Diamond H, very nice find also!

We saw an elaborately cut 1430 Aristocrat low-footed candy jar, also a 1183 Revere candy jar with cutting, and the 1483 Stanhope candy box with 605 Frosted Matte etch. A 13" cut 1228 Swirl plate, a cut 4069 Ridgeleigh

goblet, and a 5013 Shasta goblet with 924 Daisy cutting. We also saw a very seldom seen etching; it was the 9012 Victory on an old fashion. Next, was a neat 1404 Old Sandwich popcorn bowl, a Sahara 7" 1428 Warwick vase, and a Flamingo 2516 Circle Pair pitcher. What a fabulous "Show & Tell," now we can keep those pieces in our mind and get out there and find that special Heisey piece!

We ended the afternoon with Candy's homemade goodies, delicious as always! Thanks to Candy and Greg for having HCT over today! Next meeting will be May 2, in Plano, TX, at Sally's, which will be our "Wrapped and Unwrapped" Benefit Auction for HCA! Remember wrapped items must be Heisey, and worth at least \$50! Unwrapped can be Heisey pieces, odd and ends, does not have to be Heisey – anything that someone would buy to help us raise money for HCA Operating Fund! Thanks! Until then, Happy Heisey Hunting! God Bless!

Advertising Guidelines:

Advertising: Ads may be mailed to: HCA Advertising, 169 W. Church St., Newark, OH 43055; faxed to (740) 345-9638; or e-mailed to curator@HeiseyMuseum.org. Whenever possible, please e-mail your ad. Include your MasterCard or VISA number and expiration date for billing purposes, or send a check. All ads must be prepaid. When mailed or faxed, ads should be typed or printed on white paper with dark ink. Please double space. Ads that are entered in a vertical column format may contain a maximum of 65 characters per line, including spaces & punctuation.

Classified: 20 cents per word (members), 30 cents per word (non-members), \$1.50 min., 1/8 page limit. Personal ads 1/8 page limit. Abbreviations & initials count as words.

Display Ads:	member	nonmember
1/8 page (12 lines)	\$ 20	\$ 30
¼ page (25 lines)	\$ 40	\$ 60

½ page (60 lines, horizontal or vertical)	\$ 80	\$ 120
Full page (120 lines)	\$ 160	\$ 240

A charge of \$1.60 will be added for each additional line.
 ½ page: 4½" high by 7½" wide or 9" high by 3½" wide
 Full page: 9" high by 7½" wide

Ad copy must be received by the first of the month prior to publication. Reproductions (i.e., Heisey by Imperial) must be indicated. Heisey News accepts no further liability. In the event of a typographical error, the incorrect portion of the ad will be run in the following issue, but HEISEY NEWS assumes no further liability.

Abbreviations: DF=Dolphin Foot NO=Narrow Optic
 DO=Diamond Optic SO=Spiral & Saturn Optic
 MO=Medium Optic WO=Wide Optic

Classified Ads

Wanted: 1252 Twist Flamingo and Moongleam soups, goblets, dinners, etc. 904-280-0450

◆ *Paid Ad*

39th Annual
PREMIERE GLASS SHOW



Featuring 40 prominent elegant glass dealers from across the U.S.

OSUN/COTC Campus, Country Club Drive, Newark, OH
 20 miles east of Columbus off St. Rt. 16

Sponsored by Heisey Collectors of America, Inc.

In conjunction with

38th HCA National Convention



Artistry in Glass: the Heisey Etchings
 June 17-20, 2009

Thursday, June 18, 1:00 p.m. – 7:00 p.m., \$5.00
 (Ticket sales start at 11:30 a.m.)
 Friday, June 19, 12:00 noon – 5:00 p.m., \$5.00
 Saturday, June 20, 12:00 noon – 5:00 p.m., FREE

Museum Open House with FREE admission
 Tuesday June 16 – Sunday June 21

Other Convention events to include:
 Annual Meeting, Special Auction,
 ID Session / Show & Tell,
 Former Heisey Employees' Reception

For more info: (740) 345-2932, www.heiseymuseum.org
Proceeds benefit the National Heisey Glass Museum



Flea Market On The Square
Saturday, June 20th – 8am to Noon
Downtown Newark, OH
2009 Heisey Convention Event

Remember the fun and Heisey hunting of past conventions when people could set up on the Square and sell their glass? Relive the excitement on the Square in downtown Newark!

The Northern Illinois Heisey Study Club is proud to present the **ALL GLASS** Flea Market on the Square with **NO SET UP FEE**. You can get as much space as you need. Bring whatever size and quantity of tables you need. Sellers will start getting their space assignments at 7 am but no glass on the tables until 8 am. **Remember Glass only please.**

This event is a HCA event and while there is no set up fee, we will be sending around a representative to accept donations for the benefit of the HCA museum. Contact any of the following for more details and information:

Michael Maher (740) 763-4256 carolyn53@webtv.net	Kim Carlisle (317) 758-5767 kcarlisl@worldnet.att.net
Charlene Bowman (937) 289-2114 twoclbs@aol.com	
Joey Cogdill (864) 228-4741 hzhuntr@charter.net	Jeff Morrow (630) 833-4644 jmorrow64@comcast.net



Erma & Rodger Hulslander (972) 289-6159
 1427 Ridgeview St. USPS Extra
 Mesquite, TX 75149 heiseyhouse@att.net
 Will E-mail pictures!

459 basket Colonial 7" elaborate cut H	\$160
460 basket Pinwheel & Fan 7" H	350
463 basket Bonnet 8" floral cut H	170
463 basket Bonnet 9" cut bow - 1 on ea. side H	170
466 basket Fruit, 7" Width, elaborate cut H	140
479 cream & sugar footed, Petal, Sahara	75
1020 sugar bowl, Phyllis, dark Mglm H	40
1503 basket Crystalite H	350
1540 basket Lariat small dainty (knot/loop ft.) H	60
4092 cordial Kenilworth N.O. bowl	55
4091 cordial Kimberly, 1015 Dolly Madison Rose H	70
4044 cordial New Era	20
6091 cordial 1oz. Cabochon	45
3368 cordial Albemarle cut stem & ft, #867cut bowl	70
3366 cordial 1oz. Trojan H	30
1540 Cordial 1oz. Lariat H	45
3404 cordial Spanish, elaborate Pairpoint cut	55
5010 cordial Symphone, 921 Danish Princess cut	55
2351 soda Newton 12 oz. Checker Optic Hawthorne	25
1401 vase Empress D.F. crystal H	80
Heisey Stem book	55
Heisey Candlestick Book	55
"Dinky Do" gold label "Royal Doulton England"	100
"Penny" Mkd. "HN2338 Doulton & Co. Limited"	100

◆ *Paid Ad*



THIRTY NINTH ANNUAL

ALL HEISEY AUCTION
 Tuesday June 16th 2:00 P.M.
 Wednesday June 17th 9:00 A.M.
 Apple Tree Auction Center
 1616 West Church Street
 Newark, Ohio 43055
 740-344-4282

We have just received the large collection of the late Frank and Marjorie Harper of White Fish Bay, Wisconsin. Frank and Marge were long time collectors. We have 300 cartons of glass to go through and catalog. A few highlights that we know about include large Madonna, amber dolphin candlesticks, cut mailbox, large collection of candlesticks, animals, Orchid, Pied Piper, Plantation, lots of color. You may sent \$6.00 for catalogs, go to our website, or call for more details. Don't miss this great auction. www.appletreeauction.com Doors open noon on Tuesday. Sam Schnaidt and David Schnaidt Auctioneers. *****WE ARE ACCEPTING A LIMITED NUMBER OF QUALITY CONSIGNMENTS FOR THIS AUCTION. PLEASE CALL RIGHT AWAY*****

◆ *Paid Ad*



**N.I.G.C.S. 2009
 Imperial Glass Show**



Greystone Building
 corner of 32nd & Guernsey Streets
 one block from the Imperial Glass Museum
 Downtown Bellaire, OH

Dealers specializing in glassware made by:
 Imperial, Heisey, Duncan,
 Cambridge, Fostoria, Fenton and Others.

Saturday, June 13, 2009

Convention Registered NIGCS Members:
 9:00 AM - 10:00 PM
Free Admission - Open to the Public:
 10:00 AM - 4:00 PM

*also free to the public
 at the Imperial Glass Museum*

The Former Imperial Employees Q & A
Saturday, June 13 • 12:30 PM - 1:30 PM

For further information, visit our web site: www.imperialglass.org
 or write to NIGCS, P. O. Box 534, Bellaire, OH 43906

◆ *Reciprocal Ad*

10TH ANNUAL ELEGANT AND DEPRESSION GLASS SHOW AND SALE JULY 18 & 19, 2009

TENNESSEE STATE FAIRGROUNDS
 WEDGEWOOD EXIT OFF I-65
NASHVILLE, TENNESSEE

FEATURING
 ELEGANT & DEPRESSION GLASS
 EARLY AMERICAN PATTERN GLASS
 AND MUCH MORE
NO REPRODUCTIONS

SATURDAY HOURS - 10 AM TO 5 PM
 SUNDAY HOURS - 11 AM TO 3 PM

**ADMISSION \$5.00 – GOOD FOR BOTH DAYS
 FREE PARKING**

HOSTED BY FOSTORIA GLASS SOCIETY OF
 TENNESSEE
 BOB FULLER, SHOW MANAGER
 615-223-0816 OR FULLERRE@COMCAST.NET

◆ *Paid Ad*

Dealer Directory

Maximum 6 lines/12 months/\$35 MEMBERS ONLY

Contact the Editor to place your ad!



<p>KIM & PAM CARLISLE SHOWS & MAILORDERS ONLY 28220 Lamong Rd. Dept. H Sheridan, IN 46069 Glass Cleaning Services Available (317) 758-5767 kcarlisl@worldnet.att.net</p>	<p>SHIRLEY EUGENIA DUNBAR Heisey a Specialty—Mail Order, Shows, Appraisals EMAIL: shirley400@aol.com PO Box 8344, Port St. Lucie, FL 34952 Oct-May (772) 337-1558 PO Box 222, Naples, ME 04055 May-Oct (207) 647-5652</p>	<p>SUM OF LIFE Elaine Husted: 610-469-1243 Traveling through eastern PA Call, stop in, be a buyer or a browser!! E-mail: 1classycat@comcast.net</p>
<p>ALL HEISEY AUCTION Consignments Welcome Apple Tree Auction Center 1616 W. Church, Newark, OH 43055 (740) 344-4282</p>	<p>MOUNDBUILDERS SECOND GENERATION Barbara and Richard Bartlett Heisey Exclusively! 1-904-280-0450 PO Box 1931, Ponte Vedra Beach, FL 32082 Toll Free 1-888-434-7397(HEISEYS) EMAIL: CLASYGLAS2@AOL.COM</p>	<p>EAGLES REST ANTIQUES <i>Buying Heisey, China & Pottery</i> Carl and Mary Evans 62 Fieldpoint Rd., Heath, OH 43056 (740) 522-2035</p>
<p>PAULA & JEFF MORROW Elegant Glassware and American Dinnerware 126 Clinton Avenue Elmhurst, IL 60126 (630) 833-4644 mor-fab@comcast.net</p>	<p>H & R DIAMOND H Helen & Bob Rarey 1450 White Ash Dr. Columbus, OH 43204 (614) 279-0390 after 5:30</p>	<p>CRYSTAL LADY Bill, Joann & Marcie Hagerty Specializing in elegant depression glassware 1817 Vinton St., Omaha, NE 68108 Shop (402) 341-0643 or Home (402) 391-6730 Email: ejhagerty@aol.com website:www.crystalladyantiques.co</p>
<p>REALMS IN GLASS Roy Eggert Heisey Custom Stained Glass 12009 Fingerboard Rd, Monrovia, MD 21770 301-865-5196 roy54@hughes.net</p>	<p>PIECE BY PIECE ANTIQUES Buy & Sell Specializing in Heisey Glassware Bryan K. Baker Fairfax Station, VA 22039 Newark, OH 43055 (703) 250-6117 piecebypiece@verizon.net</p>	<p>PATTON HOUSE ANTIQUES Specializing in Glass*Heisey*Cambridge*Fostoria*Duncan* Factory Antique Mall, Verona, VA off I-81 Exit 227 Antiquers Mall, Booth 81, Rt. 29 N., Charlottesville, VA The Daniels, Box 547, Louisa, VA 23093 (540) 967-1181</p>
<p>C&J ANTIQUES Cole & Jean Miesner Box 45, 72 Whig St. Newark Valley, NY 13811 (607) 642-9905</p>	<p>SIBYLS OF WILMINGTON Sibyl & Ned Lavengood at Castle Corner Antiques 555 Castle St. Wilmington, NC (910) 264-9597 or Sibylsantiques@bellsouth.net</p>	<p>FRAN'S FANCY FINDS Fran & Jack Grenzebach 10534 Valencia Rd., Seminole, FL 33772-7511 (727) 391-5184 SHOWS MAIL ORDERS</p>
<p>The American Bell Association P.O. Box 19443 Indianapolis, IN 46219-0443 www.americanbell.org m</p>	<p>PASTICHE ANTIQUES at Preston's Antique Gaslight Village US 12, Allen, MI 49227 Elegant Glass and Other Fine Antiques pasticheantiques@gmail.com</p>	<p>WILLEY'S ANTIQUES & MUSEUM Specializing in Heisey 11110 Cannon Rd., Frazeeburg, OH 43822 16 miles east of Newark, OH (740) 828-2557</p>
<p>CHARLES & MILDRED FISHER Heisey animals and Heisey By Imperial animals 1607 Dayton Rd, Newark, OH 43055 Cfisher08@roadrunner.com (740) 281-3104</p>	<p>MARSH'S ANTIQUES Dick and Virginia Marsh 4532 Newton Road Newark, OH 43055 swamp@alink.com (740) 366-5608</p>	<p>MOONGLEAM ANTIQUES Heisey Glassware & American Art Pottery John Woytowicz and Peter Rivard 70 Pleasant St., Gardiner, ME 04345 (207) 582-9048 E-mail: jmwpwr@aol.com</p>
<p>ROBERT M. LOCH Voting Member HCA and NWHC Pacific Interstate Glassware Co. PO BOX 469 Custer, WA 98240 360-366-3166</p>	<p>CRESTONE MANOR UNIQUES Harold & Loleta Hammontree 3317 Crestone Circle, Chattanooga, TN 37411 423-629-1274 hammonl@bellsouth.net Heisey Only</p>	<p>APPLE VALLEY COLLECTIBLES Richard & Marilyn Garnett – Owners Shows/ Mail Order (845) 691-6308 Email: diamondH95@aol.com</p>
<p>DOWNSTAIRS AT FELTON ANTIQUES 100B Felton St, Waltham, MA 02453 781-894-2223 info@feltonstreetantiques.com GLASSWARE, POTTERY, EPHEMERA, STERLING, FURNITURE FROM EVERY DECADE!</p>	<p>WM GLASS Bill & Mary Barker 400 Nantucket Ave., Pickerington, OH 43147 (740) 927-0918 mcbarker@embarqmail.com Heisey Only</p>	<p>WATERSEdge ANTIQUES Norene & Don Walzer Shows & Mail Order 25089 Riverwalk Drive Leesburg, FL 34748 (352) 314-8975 dnnwalzer@embarqmail.com</p>
<p>JERRYS' ANTIQUES Shows Only Glassware and Other Fine Collectables PO Box 4485, Davenport, IA 52808 563-340-1871 jerrysantiques@mchsi.com</p>	<p>ONCE AND FUTURE ANTIQUES Susan & Stephen Pescatore 9 Donna Rd. Chelmsford, MA 01824 (978) 256-5418 Heisey and Elegant Glass</p>	<p>BOB & MARY KREIMER Specializing in Heisey Glass 7044 SW 116th Loop, Ocala, FL 34476 (352) 873-8306 email: rkreimer@earthlink.net. Shows and Mail Orders Only</p>
<p>J & L TREASURES Specializing in Heisey, Cambridge, Fostoria, Tiffin, Morgantown, etc Linda Kilburn, PO Box 1257, Burlington, CT 860-673-4088 jltreasures@comcast.net</p>	<p>Charlene Bowman Shows Only Heisey – Cambridge – Fostoria - Morgantown P.O Box 287, Clarksville, OH 45113 937-289-2114 twoclbs@aol.com</p>	<p>YELLOW BRICK ROAD ANTIQUES Jean Will Leavenworth, KS 66048 (913) 682-4831 Specializing in Heisey and Elegant Glassware Shows and Estate Sales</p>
<p>Just in Time Antique Mini Mall 29 North Third St Newark, OH 43055 Heisey in Stock 740-349-0001 ntleblanc@aol.com</p>	<p><i>Your Ad Could be Here</i></p>	<p><i>Your Ad Could be Here</i></p>

When Renewing Your Membership

Help ensure the future of your Museum. When you renew your membership at one of the levels below, any amount beyond the regular Associate dues goes into the Endowment Fund.

<i>Individual Contributing, one person in household</i>	<i>\$50</i>
<i>Joint Contributing, two people in one household</i>	<i>\$60</i>
<i>Family Contributing, parents and children under 18</i>	<i>\$75</i>
<i>Patron</i>	<i>\$125</i>
<i>Sponsor</i>	<i>\$250</i>
<i>Benefactor</i>	<i>\$500</i>

Visit The
National
Heisey
Glass
Museum



Come at your leisure to enjoy more than 4,800 pieces of glassware produced by A.H. Heisey and Company from 1896-1957. Hundreds of patterns are featured in all production colors. Rare and experimental items are included as well.

Facilities are air-conditioned and handicapped-accessible. Hours are 10:00 a.m. to 4:00 p.m. Tuesday through Saturday, 1:00 to 4:00 p.m. Sunday (except Jan. and Feb.). Members are admitted free, regular admission is \$4. Office hours are 8:00 a.m. to 4:30 p.m. weekdays.

Membership Renewal Notice: Check the date above your name and address on the mailing label. This is your expiration date. If it reads 5-10-09, make sure your dues are paid soon in order to receive next month's issue of *Heisey News*.

Contact the HCA Administrative Office at (740) 345-2932 for more information. The Endowment Committee wishes to thank those who have become Endowment Members and all of the individuals and study clubs that have so generously supported the HCA Endowment Fund. All members who have supported the fund are recognized each year in the February issue of the Newsletter. Your support will make the Museum self-sustaining in the years to come. Thank You all! ♦

Shipping & Handling Fees for Outside US

Additional shipping charges are required for members living outside the U.S. Current rates are Canada, \$22; for other countries, contact the Museum. Rates are subject to change at any time due to rate changes made by the US Postal Service. To verify current rates, call (740) 345-2932 or E-mail business@HeiseyMuseum.org



Periodical Postage

Paid at the Post Office
In Newark, OH 43055
Publication # 00986
POSTMASTER SEND FORM 3579 TO:
HCA
169 W. Church St.
Newark, OH 43055

To: _____

Museum Volunteers for March 2009

Jim & Karen Clark
Chuck & Amy Jo Jones
Frank Kuhlmann
Dick Marsh
Phyllis McClain
Don & Pat Moore
Ginny Priest
Russ Reopell
Judy Rhoads
Dick & Marilyn Smith
Dave & Mary Ann Spahr
Charlie & Susan Wade