

HEISEY NEWS

The Official Publication of Heisey Collectors of America, Inc.

Volume XXXVIII No. 3

March 2009

ISSN 0731-8014

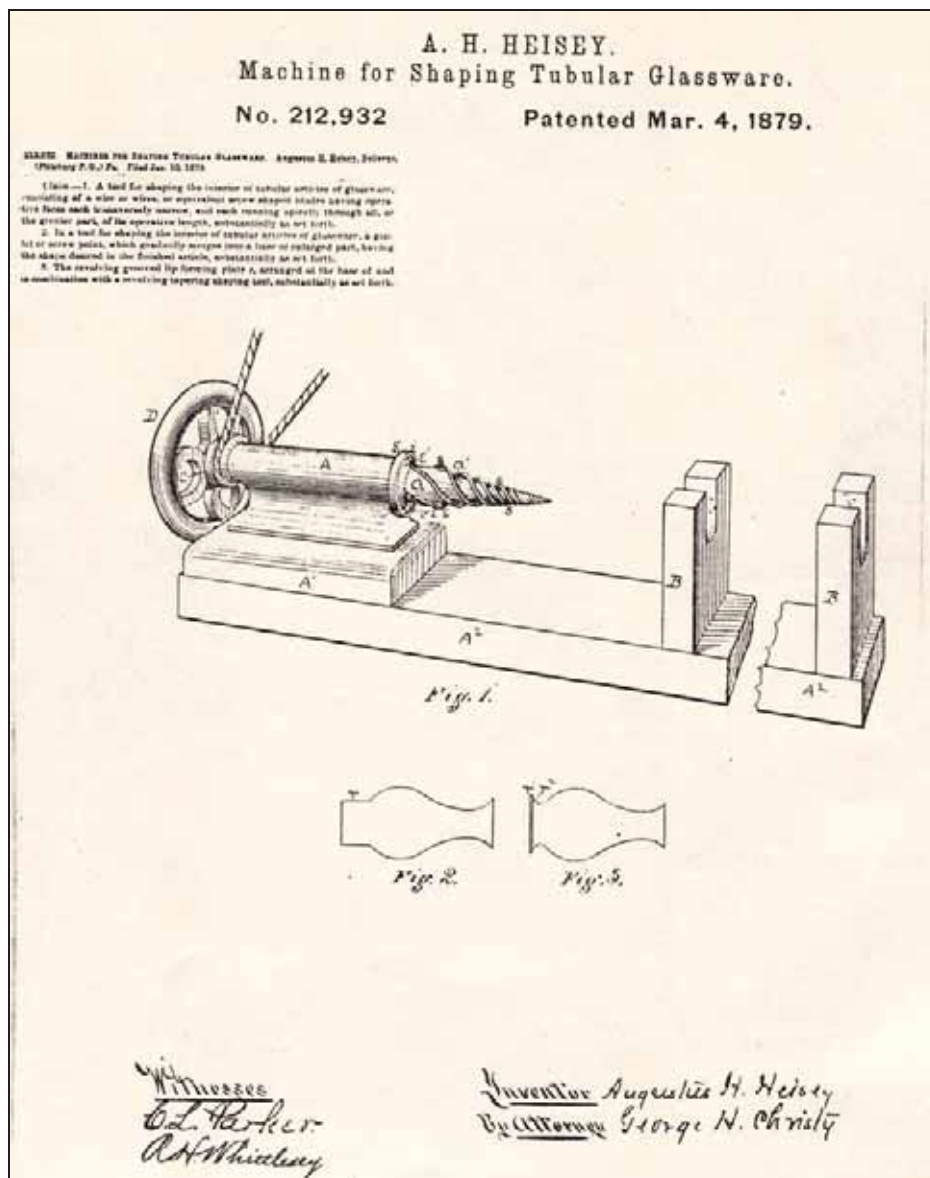

Patent 212,932

Read About A. H. Heisey Utility Patents on Page 5

HEISEY NEWS

Heisey Collectors of America, Inc.
169 West Church Street
Newark, Ohio 43055
Phone 740-345-2932 Fax 740-345-9638
Web Site: www.heiseyMuseum.org
All Rights Reserved 2009
ISSN 0731-8014

Staff and Phone Extensions

Curator, Walter Ludwig, curator@heiseyMuseum.org, Ext. 4
Business Manager, Shelly Hoberg, business@heiseyMuseum.org, Ext. 2
Clerks, Justin Church, Amanda McDonald
membership@heiseyMuseum.org, Ext. 1
Gift Shop, Ext. 5

HCA Board of Directors:

President, Bryan Baker - Fairfax Station, VA, 703-250-6117 –
hcapresident@heiseyMuseum.org
Vice-President, Charlie Wade – Newark, OH 740-587-2002
Secretary, Amy Jo Jones - Beavercreek, OH, 937-426-1567
Treasurer, Sharon Orienter – Rochester, NY, 585-288-8076
Member-at-Large, Dave Spahr - Xenia, OH, 937-372-7166

Sid Edwards – Tallassee, AL, 334-283-4663
Tom Files – Kansas City, MO, 816-468-7087
Ron Keener – Heath, OH, 740-323-3747
Sue Kilgore – Kalamazoo, MI, 269-345-3990
Robert Loch – Custer, WA, 360-366-3166
Jack Metcalf – Utica, OH, 740-892-2664
Karen Taylo – New Bern, NC, 252-637-9985

HEISEY NEWS is published and printed monthly (twice in March), by Heisey Collectors of America, Inc. (HCA). Periodical postage paid at Newark. Subscription is limited to HCA members. First class mailing is available for an extra \$20.00, due with payment of membership. If you are having difficulty receiving your Newsletter, please contact the HCA Administrative Office Monday through Friday 8:30 a.m. - 4:30 p.m.

The opinions expressed in articles in HEISEY NEWS are those of the authors and not necessarily those of the organization. The Editorial Staff reserves the right to edit, with or without the consent of the author or to refuse any material submitted for publication.

Back Issues

Back Issues available from files are \$3.00 per issue plus shipping and handling

Advertising

Ads may be mailed to: HCA Advertising, 169 W. Church St., Newark, OH 43055; faxed to (740) 345-9638; or e-mailed to curator@HeiseyMuseum.org. Whenever possible, please e-mail your ad. Always include your MasterCard or Visa number and expiration date. When mailed or faxed, ads should be typed or printed on white paper with dark ink. Camera ready ads are accepted, but must follow line specifications outlined at the beginning of the advertising section. Ads containing reproductions will not knowingly be accepted unless clearly stated (e.g. Heisey by Imperial, etc.). HEISEY NEWS accepts no further liability. In the event of a typographical error, the incorrect portion of the ad will be run in the following issue, but HEISEY NEWS assumes no further liability. See advertising section for rates and deadlines.

Museum

Heisey Collectors of America, Inc., a non-profit corporation (tax-exempt status), owns and operates The National Heisey Glass Museum in Veterans Park, 6th and Church Streets, Newark, Ohio. Open year round, Tuesday through Saturday 10:00 a.m. – 4:00 p.m., Sunday 1:00 – 4:00 p.m. (except Jan. and Feb.), closed holidays. Other hours by appointment. Members admitted free.

Identification

HCA will attempt to identify unknown glass items. Send a color photograph, measurements, and a self-addressed, stamped envelope to the attention of the Curator. Other arrangements should be made in advance with the Museum staff. Please keep in mind that the Museum cannot appraise items. Identification is free to members, non-members \$5.00 per item.

Membership

To join Heisey Collectors of America or to renew your membership, contact the HCA Administrative Office Monday through Friday 8:00 a.m. - 4:30 p.m. Eastern Time. Associate dues are \$30.00 plus \$5.00 for each additional household member. Voting members pay an additional one-time fee of \$25.00. Please consider supporting the Endowment Fund by joining at one of the levels listed on the back page.

Museum Gift Shop

There is always someone in the Gift Shop during the Museum's hours of operation to help answer questions or take orders. When ordering by phone, please have a credit card ready. When ordering by mail, please be sure to include appropriate charges such as shipping and sales tax. Please note that the HCA member discount does not apply to original Heisey or special project items.

Shipping and Receiving

Delivery is made much easier when we have a complete street address, not a PO Box. We prefer to use UPS. If you have not received a package, please call the Administrative Office to confirm it was sent. We will assist you in tracing it. If your package arrives damaged, please contact your local UPS representative. We insure everything.

Donations and Loans to the Museum

If you would like to make a donation to the Museum or have questions regarding items on loan, contact the Curator. HCA reserves the right to accept or refuse items based on current holdings.

HEISEY CALENDAR OF EVENTS

2009

HCA Benefit Auction	April 17-18
Heisey National Convention and Elegant Glass Show Newark, OH	June 17-20
Percy and Vivian Moore Memorial Weekend	October 2-3
2009 Fifth Heisey Select Auction	October 3

Table of Contents

Utility Patents Associated with A.H. Heisey & Company, Walter Ludwig	FC & 5-9
Heisey Calendar of Events	2
Message from the President, Bryan Baker	3
Curator's Report, Walter Ludwig	3-4
HCA Welcomes New Members for January 2009	4
365 Queen Anne, Joe Lokay	10-13
439 Raised Loop, Joe Lokay	13-15
Absentee Voting Procedures, Amy Jo Jones	16
36 th Annual 2009 All Heisey Benefit Auction, Dave Spahr	17
2009 Fifth Annual Heisey Select Auction	18
2009 Benefit Auction Preview Case by Museum Entrance	18
2009 Select Auction Glass List	19
Heisey Glass Museum Playing Cards, Order Form (Green Deck)	20
2009 Convention News, Co-chairs, Judy Rhoads and Mary Ann Spahr	21-22
Study Club Directory	23
Club Notes	24-25
Advertising Guidelines	25
Real Heisey in the Gift Shop	25
Classified Ads	26
Dealer Directory	27
Museum Volunteers for January 2009	BC

MESSAGE FROM THE PRESIDENT

Bryan Baker

Is it Spring yet!? Now that February has come and gone, I, like you, am itching for warmer weather. It won't be too long before we (at least me) are complaining about it being too hot, so I guess I better make the best of the weather we do have.

That having been said, what better way is there to spend a nice April weekend with all your Heisey friends than at an auction? That's right - it's just around the corner; our annual All-Heisey Benefit Auction is April 17 & 18. I won't spoil what I'm sure Walter will elaborate on; however, when I was at the Museum the other week, Walter asked if I had seen the featured glass from the auction. For those able to stop by the Museum, it's in the case to the left of the main entrance as you walk in. Anyway, I told Walter that I hadn't gotten over there yet (I was doing some work in the membership office), so he and I made our way over. He was grinning as he knew what was awaiting me. Like I said, I won't spoil his report, but let me tell you this - 20 minutes later I was still there staring at this glass with drool running down my chin.

Please mark your calendars for this all-important fund-raising event for HCA and your Museum. I believe there are over 900 lots - enough for everyone!

Make sure you also mark your calendars for this year's Convention (June 17 - 20). The Executive Committee has been meeting monthly with our convention chairs, Mary Ann Spahr and Judy Rhoads. Each meeting brings more excitement, and let me just say - this will not be your typical Convention. Mary Ann and Judy (and an army of volunteers) are really working hard to make sure this is a fun-filled week for seasoned conventioners and first-timers alike. In these financially tight times, we are making sure everyone gets their money's worth!

As I am writing this article, our new Endowment Boards are being hung in the Museum. As you recall, our current Endowment Board recognizing major contributors has begun to fill up (yippee!). These new boards, made of fine cherry, will line the hallway from the main gallery as you travel to the King House. Each board will represent a separate contribution level: bronze, silver, gold, and platinum. What a wonderful way to honor a friend, family member, or yourself by supporting our all-important Endowment Fund. Please consider giving.

As always - we Thank You for all you do for HCA and your Museum; the volunteering of your time, giving of charitable donations - and yes, continuing your membership. No matter how near or far, we all make a difference and truly matter to this organization.

Until next time,

Bryan Baker ♦

CURATOR'S REPORT

Walter Ludwig

February has been a very changeable month here in Ohio. We have had some beautiful clear crisp days, but we have also had some cold, bitter days as well. Snow has fallen, but except for one heavy snow it has not lasted long. March is now almost here, it sure is awaited with great anticipation - I need warmer weather. I am sure that winter will still leave a parting kick before it moves on, but I can bear it as long as I know that there is better weather ahead.

Things have been pretty slow here at the Museum, February is traditionally the month when we have the fewest people coming to the Museum. There were two small tours, so that has helped. We are looking forward to March when we will be opened again on Sundays. Given how slow the months of January and

February are, it was decided that we would not be open on Sundays during those months.

The auction catalog is almost ready to print. With luck, I should be able to get the catalog in the same envelope with this Newsletter for those of you who get first class mailing and have requested the catalog. A lot of great glass is available this year at our Benefit Auction. Next month, I will write an extensive article reviewing some of these beauties.

Be sure that you read the article from the Convention Co-chairs, Mary Ann Spahr and Judy Rhoads. It really looks like they have some new innovative ideas for Convention. My name seems to appear on their list of helpers quite a lot; it should be quite a time here in Ohio in June.

I want to give special recognition to Don and Pat Moore who have loaned us pieces from their extensive collection of 325 Pillows to use in our dining room display during the first quarter of the year. This is the first time we have not featured four place settings on our dining room table. The 325 Pillows pattern predates the period when Heisey was adding dinner plates or, for that matter, any plates to eat off of in their patterns. Instead, the glass was used exclusively to supplement your china. So, instead the Pillows pieces are displayed as if there was an elegant buffet or reception being held. In January, we used red to accent the pieces in honor of Valentine's Day and have now switched to green making it appropriate for a St. Patrick's Day event. There are pitchers and water bottle for your beverage, compotes and bowls for the snacks. The cake salver is ready to serve that elegant sweet. The ice bucket stands ready to be used. The cracker jar is filled with another treat. Dick and Marilyn Smith assisted with the table accessories. The display is truly beautiful. I hope that the pictures convey how well the pieces show off this truly great Heisey pattern.

With the weather beginning to be a bit better, I hope that you are able to get out and search for

that special piece of Heisey. If you are still a bit timid, then take some time to look over the Benefit Auction catalog – either the printed one that you receive in the mail or the electronic one that will be available on our web site shortly. I am sure that you will find a piece that “you can not live without.” But that piece will only be available to you if you take the action to find it in the catalog. Remember Heisey will not find you; you must track it down and then it can be yours. ♦



**Dining Room Table in King House
Set with 325 Pillows**



**King House Mantelpiece
Decorated with 325 Pillows**

**HCA WELCOMES
NEW MEMBERS
FOR
January 2009**

John & Laura Oversvee, WA

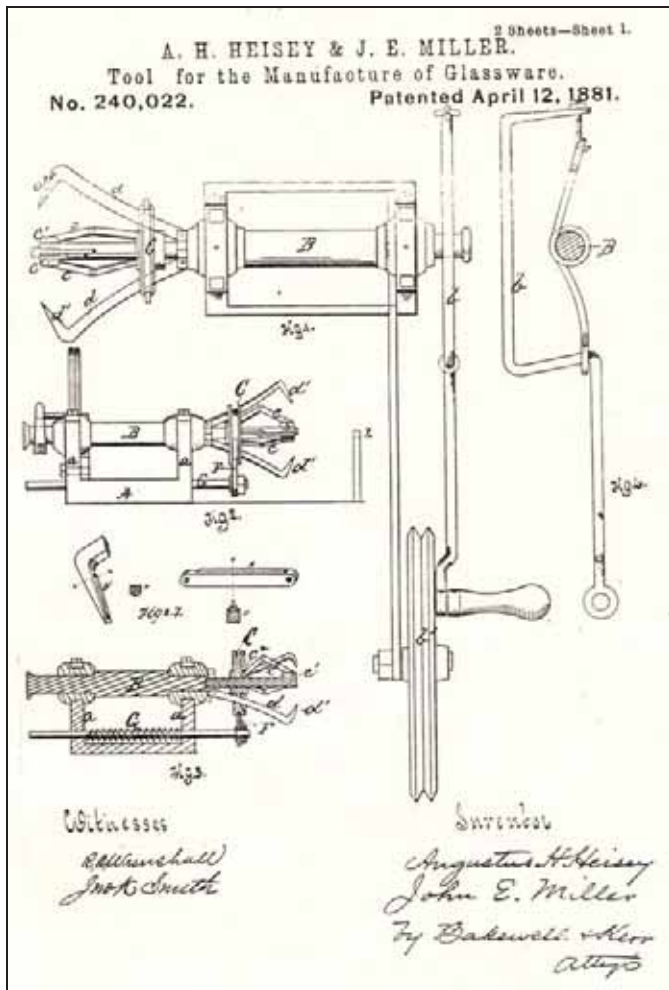

Patent 240,022 – Illustration 1

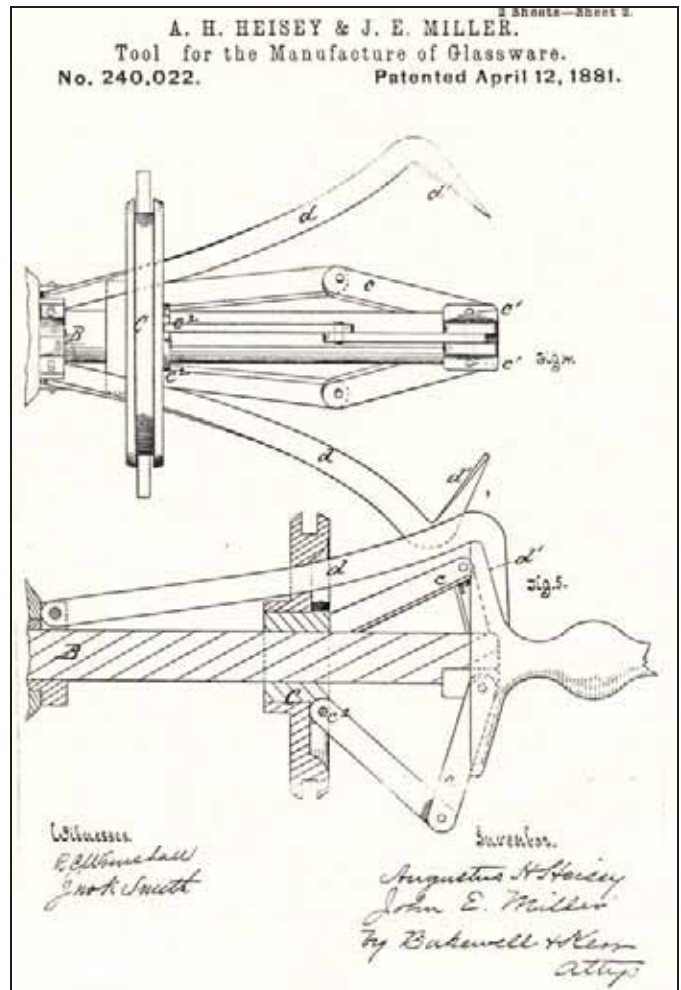

Patent 240,022 – Illustration 2

UTILITY PATENTS ASSOCIATED WITH A.H. HEISEY & COMPANY (Part 1)

Walter Ludwig

Most of the time when we have talked about patents associated with A. H. Heisey & Company, we have been talking about design patents. These are patents that cover ornamental design on a functional item. These are the patents that protected the company from infringement on the look of an item. For instance, later in this issue we talk about the patent that Heisey received for the 335 Queen Ann pattern. Used in the patent application was a nappy. The idea for a nappy was not new; instead it was only the way that the ornamentation on the nappy looked that was

protected. A totally different type of patent was necessary if there was anything innovative about the item itself. These were the utility patents (or invention patents).

In this series of articles, I am going to talk about utility patents that were granted to various workers associated with the Heisey factory. This article will specifically address utility patents that have A. H. Heisey's name attached to them that were granted before A.H. founded A. H. Heisey & Co. in 1896. The first one was granted in 1879 and the last one in 1889. There are a total of nine patents that fall in this time period. This is the period after the death of George Duncan, Sr., when James E. Duncan and A.H. Heisey were running and owned the firm George Duncan & Sons. The inventions covered by these patents were developed by employees of George Duncan & Sons, and

Heisey's name appears on them as a company officer to insure the company's interests were covered. We do not know exactly how much input that A. H. might have had on each specific invention.

The first of these patents was No 212,932 granted on March 4, 1879. The only name appearing on the patent is that of A.H. Heisey. The patent was for a machine used to shape tubular glassware. We only have one page for this patent, which is a bit odd since they usually go much longer, but all of the signatures do appear on this page. The text on the page reads:

"212,932 Machine for shaping tubular glassware. Augustus H. Heisey, Bellvue, (Pittsburg P.O.,) Pa. Filed Jan. 10, 1879.

"Claim – 1. A tool for shaping the interior of tubular article of glassware, consisting of a wire or wires, or equivalent screw shaped blades having operative faces each transversely narrow, and each running spirally through all, or the greater part, of its operative length, substantially as set forth.

2. In a tool for shaping the interior of tubular articles of glassware, a gimlet or screw point, which gradually merges into a base or enlarged part, having the shape desired in the finished article, substantially as set forth.

3. The revolving grooved lip forming plate e, arranged at the base of, and in combination with a revolving tapering shaping tool, substantially as set forth."

The reference of "e" in number 3 would be to the diagram which appears on the same page. The whole patent has been printed as the cover of this issue of the Heisey News.

The second patent is No. 240,022, which was granted on April 12, 1881 for "Tool for the Manufacture of Glassware." This patent was issued in the names of A.H. Heisey & J. E. Miller (see page 5 for illustrations accompanying the patent). The patent is much more comprehensive consisting of several drawings as well as two pages of text. This invention

"relates to the method and means employed for opening, shaping, transforming, and finishing either blown or pressed glassware." Further, "We have chosen, for purposes of illustration, to show mechanism adapted to open a cup-footed article, but do not expect or intend to be limited to the manufacture of such an article." A long, technical explanation then follows on this invention.

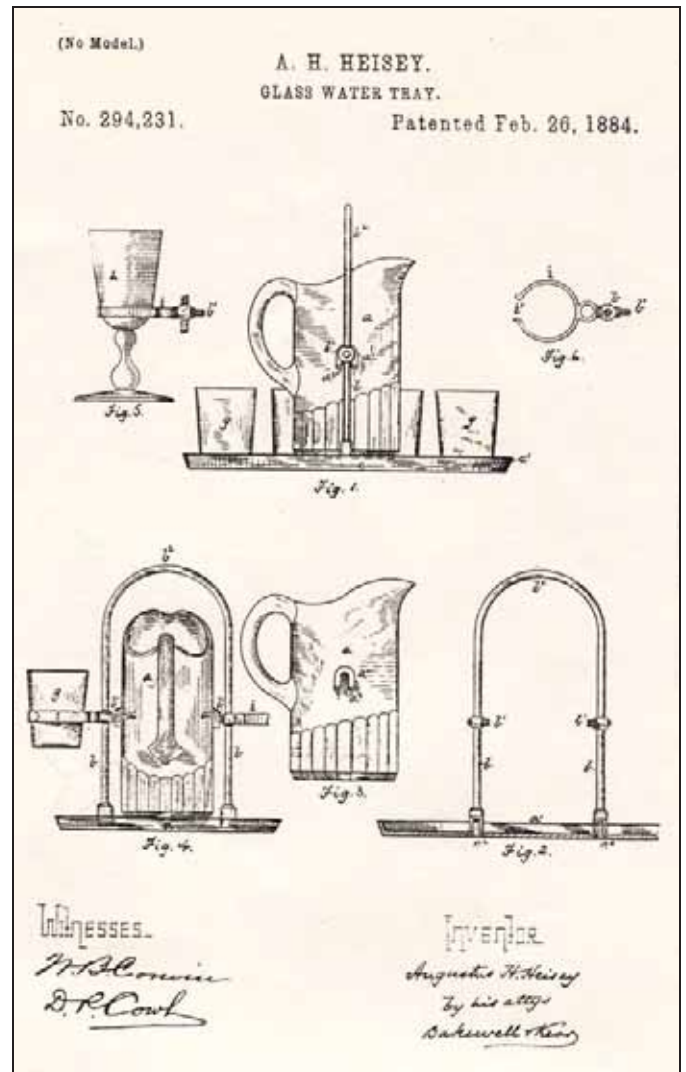

Patent 294,253

On February, 20, 1884, patent number 294,253 was granted to A. H. Heisey for a "Glass Water Tray." At this time, Heisey's address is no longer listed as Pittsburg, but instead is cited as Idlewood, PA. This invention is much easier to understand. A metal apparatus is attached to a tray and a water pitcher is mounted on the apparatus by the addition of lugs built in as part of the pitcher. The pitcher is then able to swing

freely on the apparatus allowing the user to tilt the pitcher and pour the liquid without lifting the pitcher. Additionally, goblets or tumblers can be mounted attached to the apparatus.

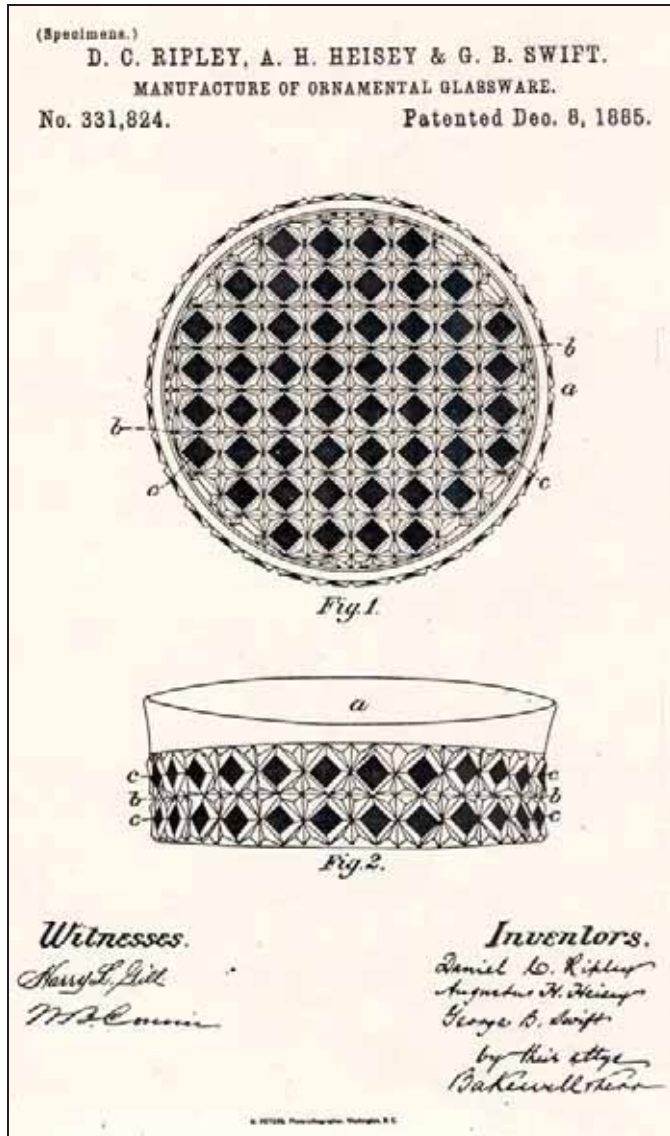

Patent 331,824

Patent number 331,824 granted December 8, 1885, is for the "Manufacture of Ornamental Glass." This patent was granted to Daniel C. Ripley, Augustus H. Heisey, and George B. Swift. The process described in the patent is to replace the expensive processes of flashing glassware and then cutting back to clear. Instead, an intricate pressed glass mold is prepared with flat surfaces. After the glass is molded the flat surfaces are flashed producing a piece that looks like it was done by the more expensive process.

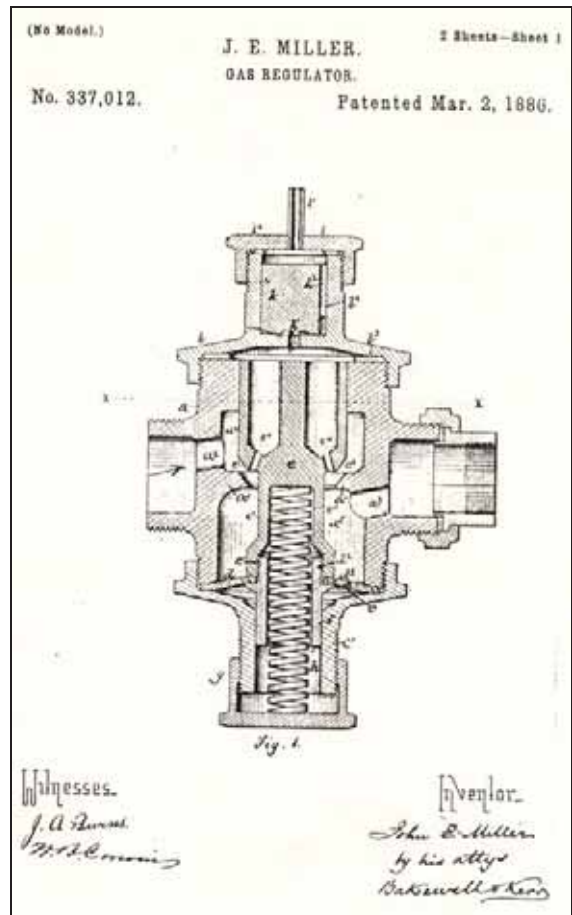

Patent 337,012 – Illustration 1

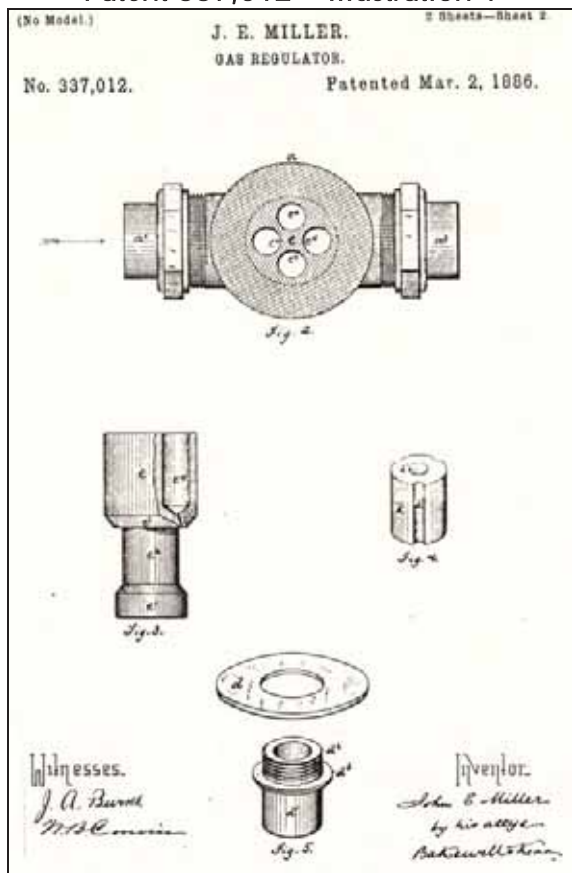

Patent 337,012 – Illustration 2

The March 2, 1886, patent (No. 337,012) is for a gas regulator. The heading reads "John Ernest Miller, of Pittsburg, Pennsylvania, Assignor of one-half to Augustus H. Heisey, of same place." The patent is for an improvement to a gas regulator to prevent leakage. The patent has a detailed description of this valve and the improvements it makes over the conventional valves of the time. A. H. Heisey is only mentioned in the heading as receiving half of the rights to the invention. This is the same J. E. Miller who is listed in some of the previous patents we have discussed.

of a partially opened umbrella with a metal handle. There is a variation with a stand for the umbrella. This little novelty piece we know was produced by George Duncan and Sons. We even have an example of the piece in a display case in the lower level of the King House.

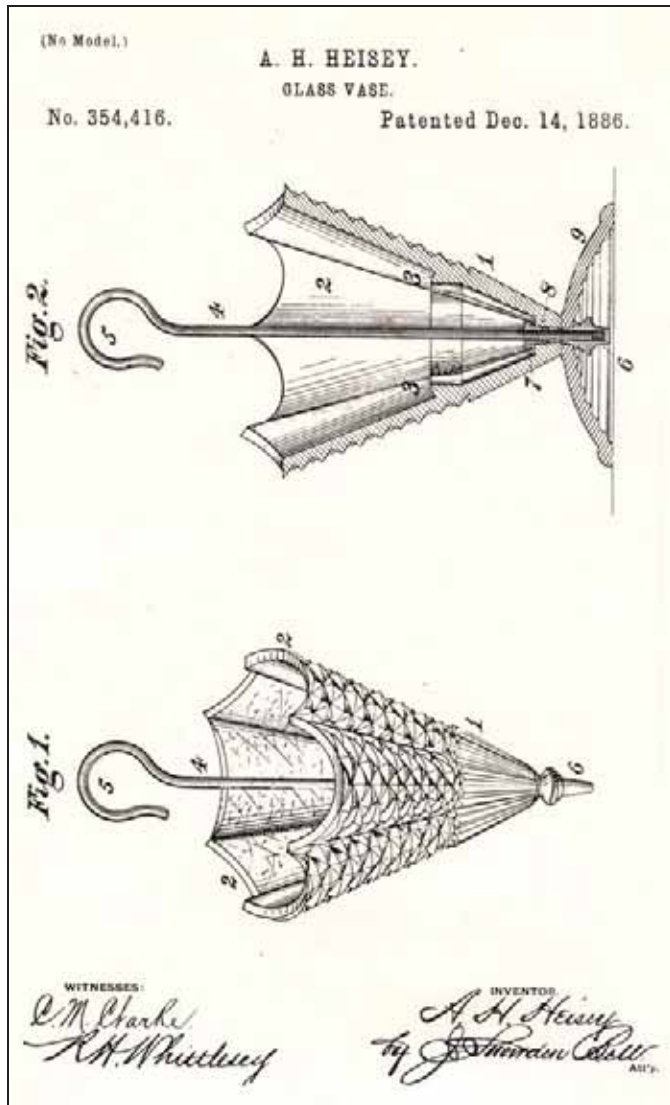

Patent 354,416

One of the more interesting patents in this series is No. 354,416, which was patented on December 14, 1886. This invention is for a glass vase and Augustus H. Heisey is listed as the sole inventor. This little vase is in the shape

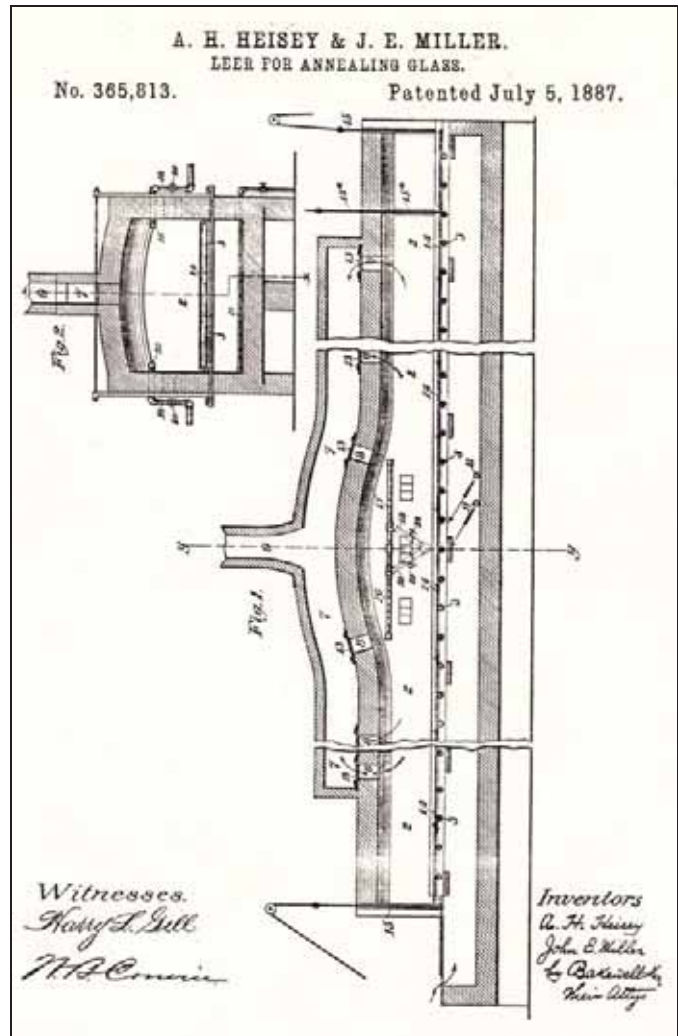

Patent 365,813

A. H. Heisey and J. E. Miller received patent No. 365,813 on July 5, 1887 for "a leer (sic) for annealing glass." In this case, both men are listed as co-inventors of this lehr. This lehr was to be used especially for the fixing of colors on decorated glass or ceramic ware so that the glass could be heated gradually to its maximum degree, and then cooled gradually before removal from the lehr.

The September 3, 1889, patent (No. 410,370) for a watch movement box was granted to "Gustave A. Moeckel and Albert C. Moeckel, of Allegheny, assignors of one-half to Augustus H.

Heisey, of Pittsburg, Pennsylvania." Again, A. H. Heisey is only entered on this patent as the assignor of one-half interest in the patent. The case in question was to be made out of glass and would keep the works or movements secure from rough handling, water, and dust.

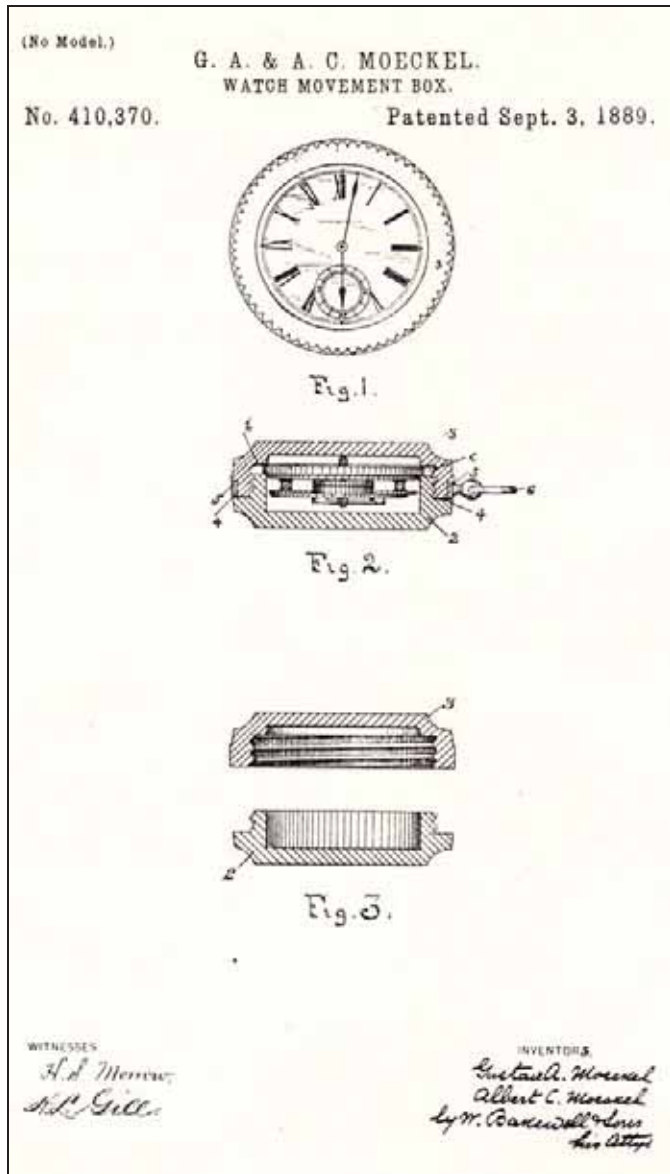

Patent 410,370

The final patent in this series is No. 414,451 granted on November 5, 1889, for a "machine for finishing glassware." The heading reads, "Harry Semple, of Steubenville, Ohio, assignor of two-thirds to Augustus H. Heisey, of Chartiers, and John Nicholson, Jr. of Allegheny, Pennsylvania." This invention, much like the first invention in this series, is to address the problem of forming the finished article immediately after it has been made and is still

hot from the oven. This invention is especially applied to jars and bottles.

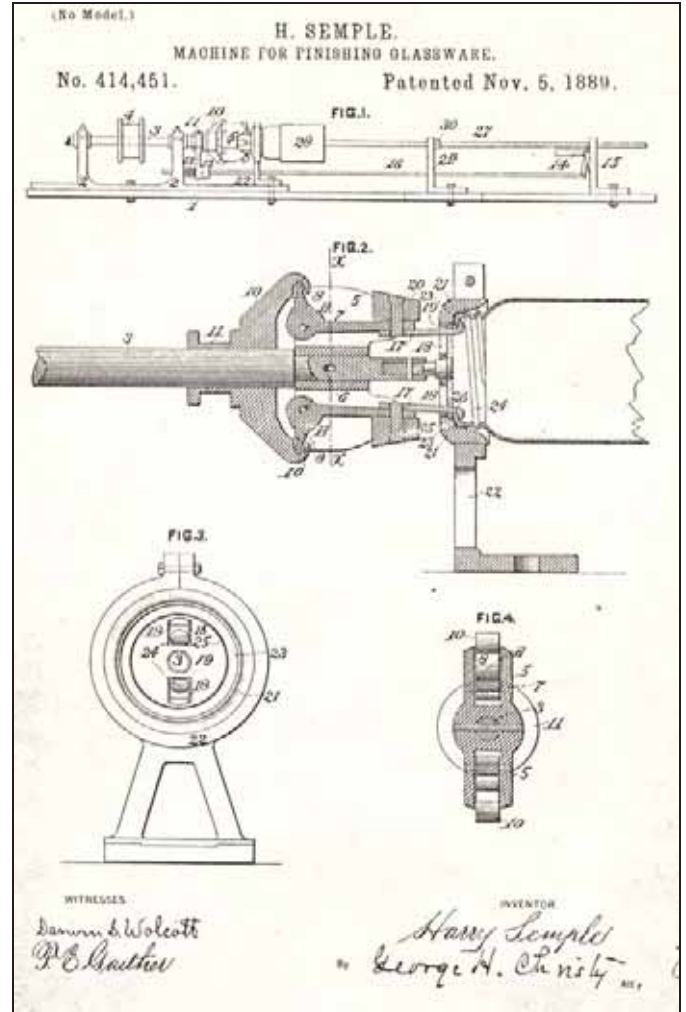

Patent 414,451

These early inventions, all of which A. H. Heisey was associated with, provide some interesting insights into the workings of a glass factory in this era. They were always on the lookout for new and innovative ways to improve the glass making process. They were looking for new products that could be brought to the consumer. Just how much input A. H. had into each of these products is hard to say. But, we do know that he was extremely interested in all aspects of the glass-making industry. The actual inventor of each of these pieces may not have been A. H. himself, but we can be reasonably sure that he had a say in just how each of these processes were developed.

Next month, I will continue with the inventions after the Heisey factory opened in 1896. ♦



365 Queen Anne – Catalog #56, Page 81

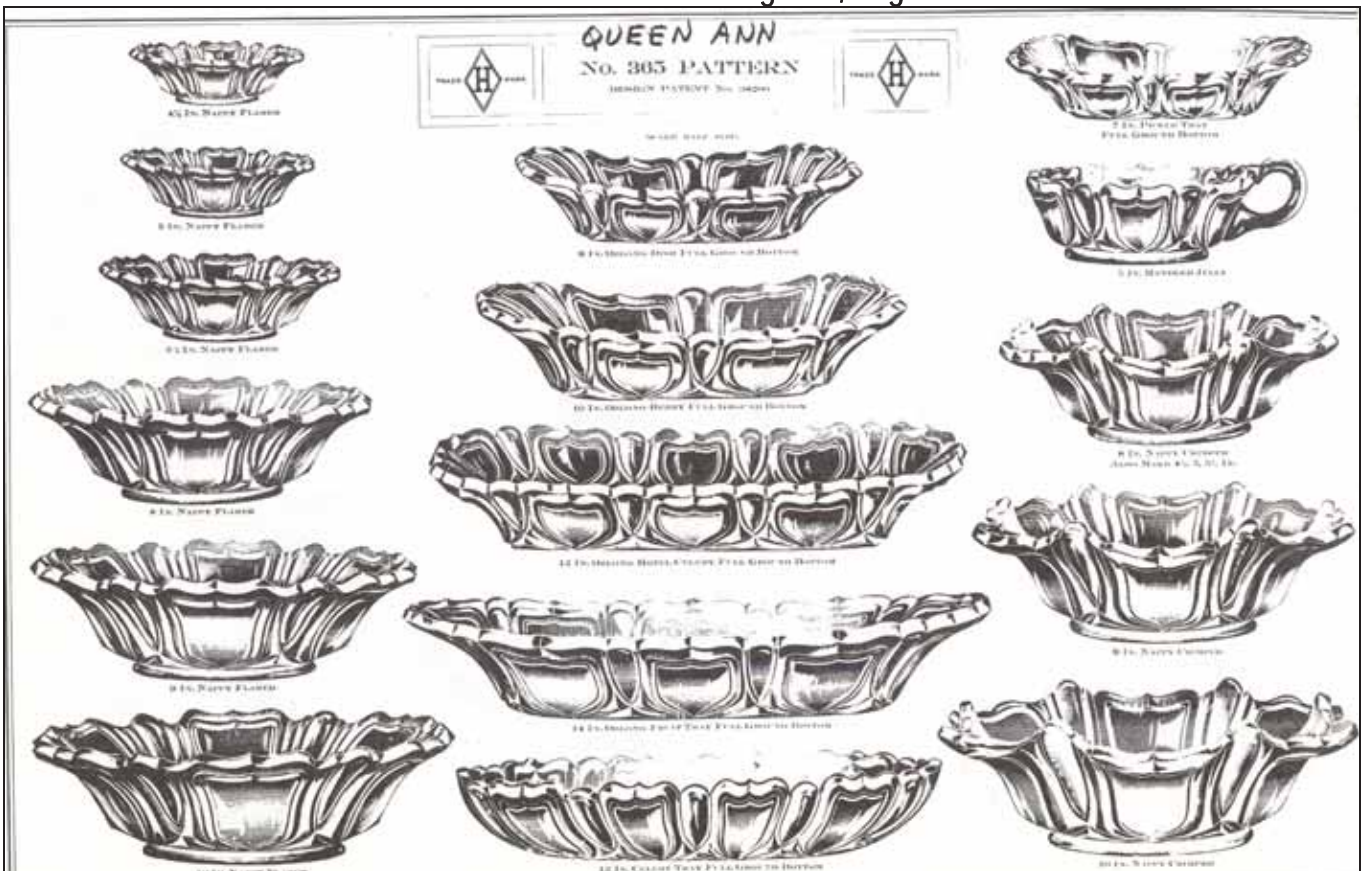

365 Queen Anne – Catalog #56, Page 82

365 QUEEN ANNE

Joe Lokay

The 365 Queen Anne pattern was introduced at the Pittsburgh, PA, glass manufacturer's show in January of 1907. On July 9, 1906, A. H. Heisey & Company applied for a design patent for the Queen Anne pattern. The spoon holder from the four piece table set was pictured to illustrate the pattern design. The patent was granted on August 28, 1907, and given patent number 38,200. The first and only Heisey Price List to offer the 365 Queen Anne pattern was #142, circa 1908. The production list with this article is from that price list.

Many pictures of 365 Queen Anne items were shown in Heisey Catalog #56, circa 1909. No pieces of the pattern were shown in Heisey Catalog #75, circa 1913. Nor was the pattern offered in Heisey Price List #155, circa 1910. It appears that Queen Anne was discontinued in about 1910. Thus, the life of the pattern was for about three years.

A total of 78 items in the 365 pattern were offered in Price List #142. There were 23 various nappies, five sizes of plates, four bon bons, six punch bowls, four jugs, and four pieces of stemware. There is a toothpick and punch cup for the collectors, as well as oil bottles and salt and pepper shakers.

The design of 365 Queen Anne is very distinctive. A shield-shaped ornamentation on each panel encircles the body of the item. The panels are separated by a vertical cut, or, as some may call it, a concave flute. On some pieces, the shields appear inverted. The pattern was made in crystal only, and pieces are usually signed with the Diamond H. Pieces are known with the shields decorated with gold, ruby stain, or ruby stain trimmed with gold. Pieces with ruby stain are especially nice and bring an added premium to the price.

The name Queen Anne is actually a company appellation for the pattern, going against the

standard company policy of the time of only having a pattern number representing the pattern. This, of course, leads to some confusion since the company resurrected the name in the 1930s when the 1401 Empress pattern was redesigned with the addition of an optic. The 1509/5009 Queen Ann pattern bears little resemblance to its older ancestor, the 365 Queen Anne pattern. The two names are distinguished with the addition of an "e" on the name of the earlier pattern. Collectors often will call 365 "Early Queen Anne", while calling 1509 "Late Queen Ann."

The 365 Queen Anne pattern is avidly sought out by collectors today, and its short production life means that there are not enough pieces around to fulfill demand. Pieces in the pattern do command a premium when they reach today's market. It truly is one of Heisey's best designs of the period; no other company produced anything comparable.

Production of 365 Queen Anne

1. spoon
2. cream
3. sugar and cover
4. butter and cover
5. nappy, 4"
6. nappy, 4 ½"
7. nappy, 5"
8. nappy, 7"
9. nappy, 8"
10. nappy, 9"
11. nappy, flared, 4 ½"
12. nappy, flared, 5"
13. nappy, flared, 5 ½"
14. nappy, flared, 8"
15. nappy, flared, 9"
16. nappy, flared, 10"
17. nappy, shallow, 4 ½"
18. nappy, shallow, 5"
19. nappy, shallow, 5 ½"
20. nappy, shallow, 8"
21. nappy, shallow, 9"
22. nappy, shallow, 10"
23. nappy, crimped, 4 ½"
24. nappy, crimped, 5"



365 Queen Anne, Catalog #56, Page 83



365 Queen Anne, Catalog #56, Page 84

25. nappy, crimped, 5 ½"
26. nappy, crimped, 8"
27. nappy, crimped, 9"
28. nappy, crimped, 10"
29. jelly, handled, 5"
30. plate, 5"
31. plate, 6"
32. plate, 9"
33. plate, 10"
34. plate, 11"
35. pickle tray, 7"
36. spoon tray, 7"
37. bon bon, no. 1
38. bon bon, no. 2
39. bon bon, no. 3
40. bon bon, no. 4
41. tray, oblong, 8"
42. berry dish, oblong, 10"
43. fruit bowl, oblong, 14"
44. celery tray, hotel, 12"
45. celery tray, 12"
46. bowl, high footed, shallow, 9"
47. punch bowl, 15"
48. punch bowl, flared, 17"
49. punch bowl, shallow, 17"
50. punch bowl, footed, 15"
51. punch bowl, footed, flared, 17"
52. punch bowl, footed, shallow, 17"
53. celery, tall
54. salver, 10"
55. jug, pint
56. jug, quart
57. jug, 3 pint
58. jug, ½ gallon
59. water bottle
60. goblet, 9 oz.
61. wine, 1 ½ oz.
62. egg cup, 5 oz.
63. sherbet, 4 oz.
64. tumbler, flared, 8 ½ oz.
65. custard (punch cup), flared, 5 oz.
66. toothpick
67. No. 1 salt or pepper, cast N. T.
68. No. 2 salt or pepper, cut shut
69. No. 3 salt or pepper, spun N. T.
70. No. 3 salt or pepper, celluloid T.
71. oil, 2 oz, pressed or cut stopper
72. oil, 4 oz, pressed or cut stopper

73. oil, 6 oz, pressed or cut stopper
74. molasses can, 13 oz., O.K. top or nickel top
75. sugar and cover, hotel
76. cream, hotel
77. finger bowl
78. finger bowl plate

References:

1. Heisey Catalog #56 (1908)
2. Heisey Price List #142 (1908)
3. Heisey Price List #155 (1910)
4. Heisey Catalog #75 (1913)
5. Heisey News, November 1974, Pattern #365
6. Heisey News, April 1984, Little Things
7. Heisey News, July 1986, Chronology 1904-1909
8. Vogel Book IV, p 143-146 ♦

439 RAISED LOOP

Joe Lokay

The 439 Raised Loop poses some unique problems for a pattern in its time period. No Heisey price list has turned up with entries for the pattern. But the pattern is pictured in Heisey Catalog #75, circa 1913. Price List #175, circa 1913, is thought of as a companion to Catalog #75, but 439 Raised Loop does not appear in it. This could be a simple matter of timing in that the Raised Loop pattern was being developed at the time that Price List #175 was published but had not been priced out for delivery at that time. The pieces themselves, however, were known and included in the Catalog #75 which was produced at approximately the same date. The Company then would have put out an addendum to the Price List, or maybe only a letter to salesmen that showed the prices of the pattern. No copy of such a document has turned up, however.

Heisey applied for a design patent for 439 Raised Loop on November 11, 1911. The patent was granted on March 5, 1912, and was given design patent No. 42,260. A Raised Loop nappy was pictured in the application. The jug was also patented and has design patent No.

45,044 which was granted on December 15, 1913. These dates just compound the mystery of why no price list has been found listing the pattern.

My estimate is that the pattern started in late 1912. This was too late to make Price List #175, but early enough to make it into Catalog #75. Since it did not make it into the next price list, I estimate that the pattern ended in 1915. This gives a pattern life of 2-3 years.

The design of the pattern is colonial with a loop in each panel. They are really more horseshoe-shaped than a loop. The area inside the loop or horseshoe is not concave but, instead, is raised out. Thus, the source of the word "raised" in the pattern name. There is an earlier pattern glass pattern that is very similar to Heisey's Raised Loop. The difference is that where the loop in Heisey's pattern is raised, the loop in the pattern glass pattern is depressed. The pattern glass pattern was actually made by several different companies and goes by the name Loop or O'Hara. Many different pieces were made.

Note the style of handles that were used on the hotel sugar and cream. The pattern was made in crystal only, and the pieces are signed with the Diamond H. The oil or cruet may not be signed.

I used the pictures of Raised Loop in Heisey Catalog #75 to make up the production list. There was a total of 32 items. Fifteen items were various nappies, one salt or pepper with the choice of four tops, one oil with the choice of two stoppers, four sizes of jugs, and an egg cup with the choice of straight or cupped. There is a tumbler as well as a custard (punch cup) for those that specialize in these items. This pattern is not an easy one to find, so have fun looking for it.

There is a 429 Fatima ashtray that is not part of the pattern. It was made from 1923 to 1937, well after production on 439 Raised Loop had ceased.

439 Raised Loop Production

1. nappy, 4"
2. nappy, 4 ½"
3. nappy, 7"
4. nappy, 8"
5. nappy, 9"
6. nappy, shallow, 4 ½"
7. nappy, shallow, 5"
8. nappy, shallow, 8"
9. nappy, shallow, 9"
10. nappy, shallow, 10"
11. nappy, cupped, 4"
12. nappy, cupped, 4 ½"
13. nappy, cupped, 7"
14. nappy, cupped, 8"
15. nappy, cupped, 9"
16. jug, pint
17. jug, quart
18. jug, 3 pint
19. jug, half gallon
20. sugar, hotel, 2 handles, no cover
21. cream, hotel
22. egg cup, straight, 5 oz.
23. egg cup, cupped, 5 oz.
24. celery tray, 9"
25. celery tray, 12"
26. tumbler, 8 oz.
27. custard (punch cup), 4 ½ oz.
28. oil, 6 oz, pressed or cut stopper
29. salt or pepper, No. 1 sanitary top
30. salt or pepper, No. 3 sanitary top
31. salt or pepper, No 43 top
32. salt or pepper, N.T. top

References

1. Heisey Catalog #75 (1913), p. 254-255
2. Heisey News, June 1978, Pattern #439
3. Heisey News, October 1982, Ash Tray #439
4. Heisey News, December 1984, #439 Little Things
5. Heisey News, September 1986, Chronology 1910-1917
6. Heisey News, October 1990, #439 Pictures
7. Heisey News, July 2004, Pattern #355
8. Vogel Book II, p 83-84, 146 ♦

ABSENTEE VOTING PROCEDURES

Amy Jo Jones

The Nominating Committee is now actively seeking voting members who desire to run for the Board of Directors of HCA. Each year, three positions on the Board are decided by a vote at the annual meeting during the June Convention. If you feel you have something to contribute as a board member, please contact a member of the Nominating Committee: Amy Jo Jones, Sid Edwards, and Dave Spahr (find contact information for them on page two of this Newsletter).

All voting members in good standing are eligible to cast votes in this election either in person or by absentee vote. (Please check your status in the list of voting members published in the February 2009 Newsletter to be sure we have it correct.) As secretary of HCA, it is one of my duties to oversee this election. I want to let you know how you go about obtaining an absentee ballot and how we process them at the time of the election.

If you would like to vote by absentee ballot in the June Board of Director's election, you may either pick up a ballot at the Museum or send in a request for an absentee ballot to the Museum by mail. The address to use is:

Absentee Ballot
HCA
169 W Church St
Newark, OH 43055

A self-addressed envelope should be included. It would help if you affix a stamp to defray Museum expenses. Requests for multiple family members can be included in the same correspondence. You may request an absentee ballot at any time after the beginning of the year.

Once the slate of candidates has been closed at the quarterly meeting held in conjunction with the Benefit Auction, ballots will be prepared. Each person requesting an absentee ballot will be assigned a number according to delivery to the Museum. We will then put a blank corresponding numbered ballot in a new envelope writing the absentee voter's name and number on the outside front of the envelope. This envelope will be put into the self-addressed envelope you sent and then mailed back to you.

Upon receipt of your absentee ballot, remove it from the envelope with your name and number on it and cast your vote. Put the ballot back into the envelope, sign at the designated line and seal. Put this envelope into a new envelope, addressing it to the address above. The deadline for receipt of absentee ballots by the membership clerk is noon on Thursday, June 18, the day before the Friday morning election.

Processing the ballots will be handled to ensure total confidentiality of all ballots. Museum staff will open the outer envelopes of all returned ballots and hold the sealed inner envelopes until the day before election. They will then be turned over to the club secretary. The names on the outer envelopes will then be checked against the eligible voting membership list checking off names of voters voting absentee. After the polls are closed, these envelopes, as well as the ballot box, are turned over to the Sergeant-at-Arms, who is in charge of the vote counting. Once all the vote counters are sequestered, the envelopes containing the absentee ballots are opened and all outer envelopes are discarded. The absentee votes are then combined with votes cast by the voting members present. It is at that time the counting of the ballots begins.

Get your request for an absentee ballot in as early as possible. Candidate statements will appear in the May Heisey News. ♥

36th ANNUAL 2009 ALL HEISEY BENEFIT AUCTION

Dave Spahr

Our 36th Annual Benefit Auction will be held **April 17 & 18, 2009**, at the same location where we held the auction last year, the GMP Local #244 Union Hall at 244 Hudson Ave., in Newark, Ohio. We finished cataloging the glass after last month's Newsletter deadline and have 936 lots.

We have received some wonderful glass for the benefit auction and, as Walter said, some exceptional pieces which one rarely sees for sale. Our curator, Walter Ludwig, will give you a full preview in an article in next month's Newsletter. You can now visit the Museum and see some of the best items in the sale on view in the case by the Museum entrance (see picture, page 18).

The auction catalog, preview hours, auction hours, absentee bid instructions, absentee bid form, bidding information and, most importantly, the list of sale items will be on our website, www.heiseymuseum.org, on or about March 15. This will give you a full month of looking and evaluating items and preparing for this great auction! Also listed are names and addresses of area hotels/motels to assist you in making reservations. You will want to arrive in time to attend the two-hour preview on Friday, April 17, 2009, 2:00 p.m. to 4:00 p.m., with the auction beginning at 4:00 p.m. On Saturday, April 18, 2009, the doors will open at 8:30 a.m.; the annual membership meeting will be held at 9:00 a.m., with the auction beginning at 9:30 a.m.

As we have done for the last two years, we have decided not to have a full mailing of the auction catalog this year. We will be sending copies on or about March 10 to members who purchased glass or put in absentee bids in 2007 and/or 2008. We will also provide a copy to any

member who wishes one - you need to call the Museum by March 15 to get your copy. If you were a buyer or absentee bidder, wait a few days before you call - give time for your copy to arrive in the mail.

As you know, the Benefit Auction is HCA's largest fund-raiser, and 2009 will be another challenging year financially for the organization. This auction is slightly larger than last year's auction, and we have an abundance of nice damage-free glass this year. If you can't make it to Newark for the auction this year, I encourage you to look on-line at the great glass and put in an absentee bid. This is a way for **every member** to support your association. Forms and instructions are available on the website as well.

Finally, here is a special note for absentee bidders. We are continuing a successful change we instituted two years ago. We are having absentee bidders make their own arrangements to have their glass shipped. We have included in the absentee bid instructions in the auction catalog those area shippers and their telephone numbers who will pick up, package, and send your glass to you. The absentee glass will be available for pickup at the Museum on Tuesday, April 21, 2009. Absentee bidders will have to pay their shippers directly. We will cooperate with your shipper and assist where we can. HCA simply does not have the volunteers, materials on hand, and staffing capability to do this task.

As you read this Newsletter, I will be looking for help at the auction - for "Vannas" to hold up the glass, for folks to help move glass during the auction, and for clean-up after the auction. If you would like to help, please contact me. It is a great way to learn about the glass and meet some great volunteers.

If you have questions or concerns, please contact me at masdgs@aol.com or give me a call at 937-372-7166. I'll see you at the auction!



2009 FIFTH ANNUAL HEISEY SELECT AUCTION

Dave Spahr

We are announcing our Fifth Annual Heisey Select Auction! Thanks to the great support you all have given in the past for this event for HCA. We have also just set the date for the auction as well - **October 3, 2009**. It will be held in conjunction with the Annual Percy & Vivian Moore Dinner which will be held in Newark this year. There will be articles about that event in future newsletters.

The first thing you can do is prepare a **list** of glass you would like us to **select** for this auction. A blank list for you to use is on page 19 of this Newsletter. Please note the blank list contains space for twenty lots - each member is allowed to submit **forty lots** for the committee to select from. Remember, this auction benefits **your** association. Consider making a donation of a piece - 100% of the proceeds from the sale of that item will go to support HCA and the Museum. Donations don't count towards your 40 lot limit. We hope Study Clubs will donate glass for the auction - a great project for them!

This year, consistent with the last three select auctions, the consignment fee for each lot will be 20% with a minimum consignment fee of \$5. This means anything that sells for under \$25, the consignment fee will be \$5. As you prepare your list, please make them as descriptive as possible since the committee will be using them to select glass for the auction. It is very important that you carefully check for damage - we are selecting only undamaged glass for this special auction. The **deadline** for submitting your completed lists to us is **May 18, 2009**. Remember - send in NO glass - just the list with up to forty lots.

The committee's target is to have an auction with two hundred (200) lots. How can you get

your glass selected? Here are some clues. Consideration will be given to include diversity in color, etchings, cuttings, and patterns. A main goal in the selection will be not to have any duplication of lots. We would like glass for the experienced collector who wants that exotic piece of Heisey and glass also for the fledgling collector just starting out. As mentioned earlier, we will not select damaged glass.

The Select Committee will be busy after May 18 and contact you on or about June 1 to let you know the glass it has selected. Hopefully, you will be able to bring your glass to Newark and drop it off at the Museum when you come to the Convention on June 17-20. The auction will be held in the lower level in the Museum in the activity center. Please look over your glass and begin your lists soon. May 18 will be here before you know it!

This event has been a success for consignors and those purchasing wonderful Heisey glass. Plan on attending and participating in this auction for the benefit of your Museum.

If you have any questions, please e-mail or call Dave Spahr, masdgs@aol.com or (937)-372-7166. Happy Heisey Hunting! ♦



2009 Benefit Auction
Preview Case by Museum Entrance

2009 SELECT AUCTION GLASS LIST

FOR THE BENEFIT OF HCA

Consignor/ Owner: _____

Address: _____

Daytime Phone: (____) - ____ - _____ Fax or E-mail _____

SEND TO: Select Auction, c/o HCA, 169 W. Church St., Newark, OH 43055

DEADLINE: List must be received by May 18, 2009

Lot #	Qty	Pattern #/ Name	Description	Cut/Etch	Color	H	Damage
1							
2							
3							
4							
5							
6							
7							
8							
9							
10							
11							
12							
13							
14							
15							
16							
17							
18							
19							
20							

**Please put a "D" beside the lot number if the lot is to be donated to HCA.
Each consignor may submit up to 40 lots.**



HEISEY GLASS MUSEUM PLAYING CARDS

We are now taking orders for the Heisey Glass Museum Playing Cards (Edition 3 - Green Deck) which we expect to receive early February. In addition, we will have for sale a limited number of uncut sheets (21" x 25") which will be suitable for framing. This deck features the Heisey animals and animal related items. The full color pictures are stunning and will make a good learning tool as well as a nice gift for all of your glass collecting friends. We will ship as soon as available. Orders for Card Cases (Cobalt) and the Red deck may also be placed on this form.

Name _____
 Address _____
 City _____ State _____ Zip _____
 Phone and/or E-mail _____

I wish to order:	Total
_____ (number) Heisey Glass Museum Playing Cards (Green) @ \$10 each	_____
_____ (number) Heisey Glass Museum Playing Cards (Red) @ \$10 each	_____
Shipping per deck \$ 1.50 (can be picked up at Gift Shop)	_____
_____ (number) Uncut sheets of Heisey Playing Cards (Green) @ \$25 each	_____
_____ (number) Uncut sheets of Heisey Playing Cards (Red) @ \$25 each	_____
Shipping per uncut sheet @ \$5.00 each (can be picked up at Gift Shop)	_____
_____ (number) 1508 Card case in Cobalt @ \$24.95 each	_____
Shipping per card case @ \$6.00 each (can be picked up at Gift Shop)	_____
Grand Total (tax will be added when appropriate)	_____

Check # _____ Visa _____ Master Card _____
 Card Number _____ Exp _____

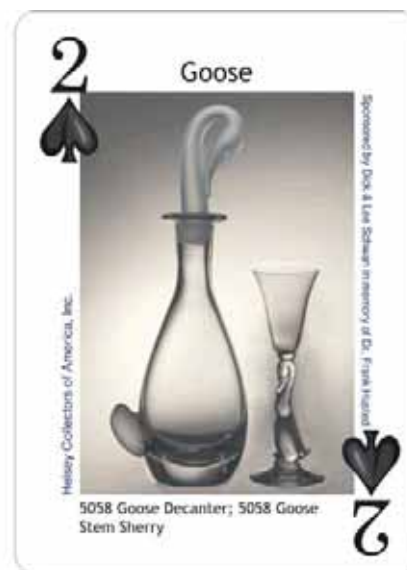
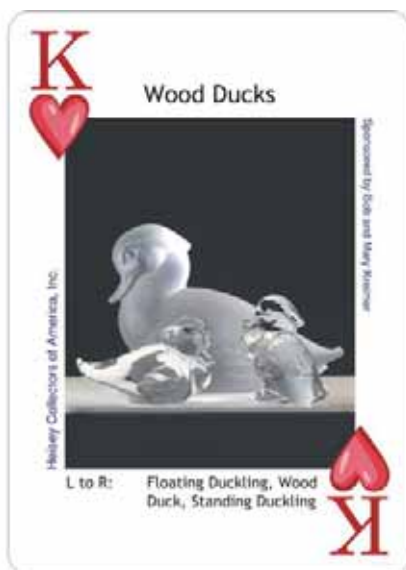
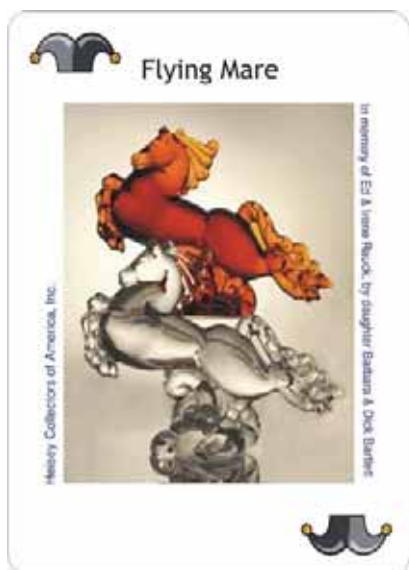

2009 CONVENTION NEWS

Judy Rhoads & Mary Ann Spahr, Co-Chairs

CONVENTION AMBASSADORS (452)

We proudly announce the following volunteers and clubs for lending their time and expertise to make your 2009 convention a great experience:

Publicity: Amy Jo Jones, Walter Ludwig

Registration: Phil Abrams, North Carolina Study Club

First Timers' Greeters & Mentors: Sid & Mary Edwards

Welcome BBQ Mixer:

Seminars: Walter Ludwig, Curator

Study Club Meeting: Bryan Baker, HCA President

ID / Show & Tell: Walter Ludwig

Former Employees Reception: Tom & Kathy Files

HCA Annual Meeting: HCA Board of Directors

Annual Banquet: Judy Rhoads, Mary Ann Spahr

Banquet Auction: Charlene Bowman

Historic Heisey Driving Tour: Dick Marsh, Tom Heisey

Flea Market on the Square: Jeff Morrow, Northern Illinois Study Club

Hospitality Room: Karen Clark, Pat Moore

Premiere Glass Show: Sharon Orienter, Russ Reopell

Want to help in any events? There is a place for you! Please contact Convention Chairs Judy Rhoads (kjrroads@aol.com) or Mary Ann Spahr (masxenia@aol.com).

HOSPITALITY PREVIEW

by Karen Clark and Pat Moore

We hope your **Zodiac (429)** is telling you to come to Newark this year for convention. To all Heisey hunters and collectors who come from points from the **Arctic (9009)** to the **Antarctic (454)**, to every Heisey **Sportsman (455)**: grab your **Winchester (517)** and head for the **Tavern (510)** of hospitality in the Multi-purpose Room at

the Museum. Come in the June **Springtime (457)**, be careful of the **Plantation Ivy (516)**, and join us for our not so **Chintz-y (450)** selection of snacks and light liquid refreshments. Everyone will be there: **Pan (9010)**, **Diana (442)**, **Rosalie (497)**, and the **Pied Piper (439)**, too.

We are asking the **Old Colony (448)** of collectors and friends for donations of food, money, or volunteer time to keep the soft **Cocktail Party (522)** running smoothly. The **Tavern (510)** hospitality will be open on Thursday and Friday of convention from 10:00 a.m. to 4:00 p.m. Hours on Saturday will be short due to other activities that will be held, hopefully not on a **Frosty Dawn (491)** or **Jack Frost (9022)** morning.

Call or e-mail about your donations of snacks or volunteer time to Karen Clark (e-mail: karen9132@prodigy.net, phone: 937-845-9132), Pat Moore (e-mail: pmoore42@columbus.rr.com, phone: 740-966-3089).

Thanks to **You**, from **Me and Us (9013)!** Tally **Ho (467)** for now!

For First-Timers' Eyes Only (Everybody Else, At Your Own Risk)

How many times have you contemplated attending the Heisey Convention, but decided to stay home? Perhaps concerns like these came to mind: "*We've never been to Newark. We don't know where to go.*" "*We won't know anybody else.*" "*We just started collecting. Everybody there is an expert. What if they think my questions sound silly?*" If this sounds like your internal dialogue, then read on!

First, all of us had a first Convention. Second, we are not all experts. And, third, you will find that glass-collecting folks are some of the friendliest people in the world.

You will meet welcoming smiles from the members of our North Carolina Study Club, who manage our registration table on Wednesday

and Thursday. They will give you name tags and a bulging registration packet that will give you much information: maps, schedules, local directories, coupons for the Museum Gift Shop, and even a self-driving tour of significant Heisey sites in Licking County.

Plan to attend our first Convention event, the Welcome BBQ Mixer, on Wednesday evening. You will be officially welcomed at this Heisey family gathering, be able to meet other first-timers, and meet Mentors. Mentors are volunteers whose mission is to be especially available to first-timers during Convention – to answer questions, introduce you to other Heisey folks, rejoice with you over a new found treasure, and commiserate with you over the piece of glass that got away. They might even have hot tips on good restaurants in town. Enjoy your new Mentor-friends.

Convention is always full of opportunities for learning. Take advantage of all of them. Our Museum Curator, Walter Ludwig, is planning two information-packed Seminars on Thursday and Friday that will highlight etchings and the etching process. The Glass Identification Session on Thursday evening features a panel of experts on Heisey and other glass companies. This session is always a favorite with Convention goers. To add to the excitement this year, a Show and Tell feature invites folks to bring their found treasures to display for everyone to enjoy. A Museum event on Wednesday night will feature an activity that will acquaint you quickly with the fine Heisey glassware on display.

A wide variety of opportunities for buying glass are available. You will find a wonderful array of Heisey in all price ranges at the Premiere Heisey Glass Show on Thursday, Friday, and Saturday; at the Flea Market on the Square on Saturday morning; in the Museum Gift Shop; and local antique shops. Dealers are always eager to talk to folks and answer questions.

For a slice of living history, drop in on the Former Employees Reunion on Friday. There

you will meet some of the delightful folks who worked in the Heisey factory. Do they have stories to tell!

There are also opportunities to learn about HCA and how it works. To find out about local study clubs, or perhaps get information on how to form a study club in your area, you can attend the Study Club Meeting on Thursday morning. At the HCA Annual Meeting on Friday morning, you will learn more about our organization and be able to meet still more Heisey collectors.

We hope you will sign up for our most festive activity, the Banquet on Friday evening. You will be seated at a table with a variety of Heisey collectors – another opportunity to get acquainted. At the Banquet, you will also have another chance to buy a beautiful piece of Heisey glass in a special auction.

So, give some serious thought to joining us this year. You will see more beautiful Heisey glass than you can imagine gathered in one spot, and we guarantee you will find us friendly and welcoming and eager to trade glass stories with you! ♦



Study Club Directory

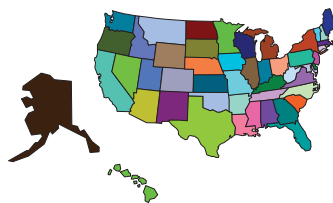

Interested in joining a study club? You will have the opportunity to meet fellow collectors and HCA members and learn more about your favorite glassware. If your club is not listed or you need to make corrections to your listing, please contact the Museum.

STUDY CLUB	MEET WHEN?	WHERE?	Email/Web Site	CONTACT
#4 Central Illinois Helsey Collectors Club	Four times a year	Members' homes or restaurants		Joyce Deany (815) 432-4310
#5 Bay State Helsey Collectors Club	2 nd Tuesday of each month except July, Aug., and Dec.	Whole Foods Community Rm, Bedford, MA	spescatore@houghton.com	Stephen Pescatore (978) 256-5418
#7 Dayton Area Helsey Collectors Club	3 rd Tues. of the month Sept. to May, 6:30 p.m.	Huber Heights Library	LH937@aol.com	Joe Harner (937) 372-0852
#8 Helsey Heritage Society <i>NJ, Eastern PA and DE areas</i>	Four times per year	Members' homes	craigkratochvil@aol.com	Craig Kratochvil (973) 962-4004
#13 Helsey Club of California	4th Sunday every month, 12:30	Members' homes	herbet@sbcglobal.net www.heiseyclubca.org	Norval Heisey (818)-349-0945
#14 Northern Illinois Helsey Club	Four times a year	Members' homes	niheisey@comcast.net	Jeff Morrow (630) 833-4644
#15 Helsey Collectors Club of Michigan	Every six weeks, August to May	Members' homes	kilgoredesigns@att.net	Sue E. Kilgore (269)-345-3990
#16 Helsey Collectors of Texas	2 nd Sat. of every odd month except May 1st Sat., 1 p.m.	Members' homes	sanddollars97@tx.rr.com www.heiseycollectorsoftexas.com	Greg Freeman (817)-545-5889
#19 Helsey Collectors of the Rochester Area	10 meetings per year: Sunday, 2:30 p.m.	Members' homes	seo2@aol.com	Sharon Orienter (585) 288-8076
#20 Buckeye Helsey Collectors Club <i>Newark, OH area</i>	September to May, 4th Monday	Members' homes or the Museum	Theflyingmaher@webtv.net	Michael Maher (740) 763-4256
#22 Northwest Helsey Collectors	First Saturday of the month	Members' homes	bahama50@hotmail.com	Deborah de Jong (425) 868-0457
#25 Helsey 76'ers <i>Columbus, OH area</i>	Once a month, September to May	Members' homes	ldburg48@aol.com	Colleen Burgess (614) 882-1884
#31 Nassau Long Island Helsey Club	Generally every other month	Members' homes		Babs Kent (516) 228-8274
#32 Dairyland Helsey Club	Once every two months	Members' homes		Ray K. Courtnage (414) 962-9747
#33 Golden Gate Helsey Collectors Club <i>Northern California</i>	Quarterly	Members' homes		Russ Nicholas (707) 762-2494
#36 Helsey Club of Southern MA	April, June, September, December			Maria Martell (508) 833-0633
#38 North Carolina Helsey Study Group	6 meetings per year: Jan.; March, May, July, Sept., Nov.	Replacements Ltd Greensboro, NC	Nchsg@yahoo.com www.northcarolinaheiseystudygroup.org	Karen Taylo (252) 637-9985
#39 Florida Helsey Collectors Club	4 times per year: January – February-March-April	Westchester Country Club Boyton Beach, FL	Shirley400@aol.com	Everett Dunbar (772)-337-1558
#42 Gulf Coast Helsey Club of Florida	Nov., Jan. and March; 2 nd Thursday 11:00 am	Members' homes		Jack Grenzebach (727)-391-5784
#43 Tri-State Helsey Study Club <i>OH, IN, MI</i>	1st Sat. every 3 rd month	Members' homes	Maxwellm@cktech.biz	Mike Maxwell (260) 925-3484
#45 Hoosier Helsey Club	Four times a year	Warren Library, Indianapolis, IN		J. David Litsey, (317) 872-7800
#48 Dixieland Helsey Study Club	Odd number months, 2 nd Saturday night	Members' homes	www.dixielandheisey.org	Craig German (770) 967-8733
#49 Great Plains Helsey Club	March, May, July, September, and November	Members' homes	cameron_mg@mchsi.com www.greatplainsheiseyclub.org	Mary Cameron (515) 292-3743
#50 Northwoods Helsey Club of Minnesota	Four times a year	Members' homes	wheise@comcast.net	Bob Heise (952)-831-9335
#51 Helsey Club of Northeast Florida	Feb., May, Aug., and Nov. 2 nd Thursday	Avonlea Antique Mall, Jacksonville	Clasyglas2@aol.com	Barb Bartlett (904) 280-0450
#52 Northern Virginia Helsey Study Club	Monthly, Sept. – May	Members' homes	rreopell@verizon.net	Russ Reopell (703) 250-6117

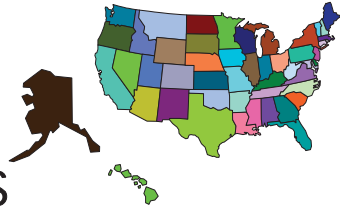

CLUB NOTES

Heisey Collectors of Texas *Erma Hulslander*

Margie was our hostess for HCT's first Study Club meeting in 2009! On January 10, we were back in Plano, TX, with attendance of 14 members and visitor Cindy, a guest at Margie's home.

Our Prez Greg had a short business meeting, reminding everyone that the first Saturday in May, will be our Benefit Auction with Sally hosting the meeting.

Margie had asked Greg to have the program at her meeting, which he was pleased to do. Greg chose "Verlys" for his program, which was really great, a subject HCT had never touched on before. Originally a French glass, Verlys was made in Newark, Ohio, by Holographane Company from 1935 to 1951. Most everyone knew Heisey made Verlys pieces, but never knew how you could tell Verlys made by Heisey. The Verlys items, which were produced by Heisey from 1955 to 1957, were not signed. Some of the Verlys pieces we enjoyed looking at included the V-835 Wild Ducks bowl, 13 ½" in Heisey's beautiful Limelight. The 12" bowl with Birds and Bees, made by Verlys of American, hand signed in the middle of the bowl, was interesting to see, also. Two of Heisey's Verlys bowls, the V-862 6 ¼" Pine Cones bowl and the V-8636 8 ¾" Thistles bowl, we all enjoyed seeing. The Thistle and Pine Cone bowls seem to be the most common among our members. Greg had handouts on the Verlys glass made by Heisey, which will be very helpful for us collectors in the future.

Our "Show & Tell" was great as always! When you only meet every other month, it gives everyone a lot of time to get out there and find some interesting pieces of Heisey! And that we did! Actually, just before the meeting started, right down the street, in an antique & collectibles mall, Greg and Candy found a 1503 Crystolite 13" Shell, square hinge! That tells us, you just have to look and look again! As usual, I get carried away looking at all pieces of Heisey, and forget to write everything down. What I did write down was, a console set, in 1567 Plantation with 516 Ivy etch, a floral bowl with a pair of 5" one-light candlesticks, a Spanish (3404) soda with 456 Titania etch, and an ashtray which looked like Whirlpool but just did not look quite right, but later we found it was the 1500 ashtray. Another large hunk

of glass was the 400 ½ Colonial Scalloped Top, high-footed shallow bowl. Contrasting this, were the real slim Flamingo 1001 Caswell sugar sifter and creamer which are so elegant. Have you ever seen a 1184 Yeoman 10 ½" dinner plate in Marigold with 447 Empress etch? We did! We also were privileged to see the 1250 Groove & Slash cracker jar and cover which was very unusual because the cover to the cracker jar has no knob – no nothing on the top, so obviously very few jars will still have their covers!

Margie had just received her "Cooking with Paula Deen" magazine - the January/February issue. An article in this magazine said "Worth Collecting" hospitality etched in glass (Plantation). It showed several different Heisey Plantation pieces, really neat to see!

Margie, with the help of her guest Cindy, served different desserts on Heisey 1567 Plantation pieces. She even had our coffee in Heisey 507 Orchid etch cups and saucers.

We will see everyone in Bedford, Texas on March 14, 2009. God Bless! ♦

Northwoods Heisey Club of Minnesota *Virginia Johnson*

The Northwoods Heisey Club of Minnesota will have their meeting at 1 p.m. Saturday, March 14, at the home of Odell & Virginia Johnson, 8102 Highwood Dr., B121, Bloomington, MN. The program will be "Heisey Etchings" presented by Carol Olson. Members are asked to bring a piece of Heisey with an etching for viewing and discussion. Refreshments will be served. Members, guests, and those interested in Heisey Glass are invited. Contact for directions and further information: telephone 952-830-9421. ♦

Gulf Coast Heisey Club *Mar Kreimer*

The Gulf Coast Club met on January 8 at the home of Judy Biniasz in Land O' Lakes, Florida. At this meeting we had our fund-raiser for HCA: a silent auction of donated Heisey glass and a mystery auction. We all went home with a new piece of glass (or more) and Randy Pierson walked off with the big prize – a rabbit paperweight. We had a great time and HCA will benefit to the tune of \$850.

The Show and Tell items included a pair of Flamingo 107 Wellington candlesticks, a 4085 Kohinoor Zircon smoke set, 3381 Creole water goblets in Alexandrite, a 7011

Daffodil bowl and nappy, and a 3 Small Elephant in Amber...Santa was very generous to our members!

At the Clearwater Glass Show in February, Jack Grenzabach set up a display of Heisey baskets from his collection and from the collection of Jean Marsa. It was spectacular and very much enjoyed by all who attended the show.

Our next meeting will be on Wednesday, March 18 at the home of Don and Norene Walzer in Leesburg, Florida. We welcome guests, so please join us if you are visiting in the area. Please call the Walzers at 352-314-8975 for details. ♦

Advertising Guidelines:

Advertising: Ads may be mailed to: HCA Advertising, 169 W. Church St., Newark, OH 43055; faxed to (740) 345-9638; or e-mailed to curator@HeiseyMuseum.org. Whenever possible, please e-mail your ad. Include your MasterCard or VISA number and expiration date for billing purposes, or send a check. All ads must be prepaid. When mailed or faxed, ads should be typed or printed on white paper with dark ink. Please double space. Ads that are entered in a vertical column format may contain a maximum of 65 characters per line, including spaces & punctuation.

Classified: 20 cents per word (members), 30 cents per word (non-members), \$1.50 min., 1/8 page limit. Personal ads 1/8 page limit. Abbreviations & initials count as words.

Display Ads:	member	nonmember
1/8 page (12 lines)	\$ 20	\$ 30
¼ page (25 lines)	\$ 40	\$ 60
½ page (60 lines, horizontal or vertical)	\$ 80	\$120
Full page (120 lines)	\$160	\$240

A charge of \$1.60 will be added for each additional line.

½ page: 4½" high by 7½" wide or 9" high by 3½" wide

Full page: 9" high by 7½" wide

Ad copy must be received by the first of the month prior to publication. Reproductions (i.e., Heisey by Imperial) must be indicated. Heisey News accepts no further liability. In the event of a typographical error, the incorrect portion of the ad will be run in the following issue, but HEISEY NEWS assumes no further liability.

Camera Ready Ad Specifications:

1/8 page: 2¼" high by 3½" wide

¼ page: 4½" high by 3½" wide

½ page: 4½" high by 7½" wide or 9" high by 3½" wide

Full page: 9" high by 7½" wide

Camera ready ads may be resized because of space concerns

Ad copy must be received by the first of the month prior to publication. Reproductions (i.e. Heisey by Imperial) must be indicated. Heisey News accepts no further liability. In the event of a typographical error, the incorrect portion of the ad will be run in the following issue, but HEISEY NEWS assumes no further liability. ♦

Abbreviations: DF=Dolphin Foot NO=Narrow Optic
DO=Diamond Optic SO=Spiral & Saturn Optic
MO=Medium Optic WO=Wide Optic

Classified Ads

REAL HEISEY IN THE GIFT SHOP

All crystal and all prices are each unless noted.

Supply changes daily. Please contact the Gift Shop before placing an order.

Item	Price
150 Banded Flute punch cup H (6 each)	\$15
300 Peerless bar glass, H	10
343 Sunburst butter top only H	25
351 Priscilla butter pat, H	10
394 Narrow Flute 4 ½" chow chow, H	25
411 Tudor sherbet, H (4 each)	10
411 Tudor cruet, H	35
411 Tudor punch cup, H (4 each)	5
412 Tudor champagne, H	10
413 Tudor champagne, H (4 each)	10
413 Tudor sherbet, H	5
417 Double Rib and Panel cruet, H	20
417 Double Rib and Panel oyster cocktail, H	5
475 Narrow Flute/Rim salted nut, plain bottom H	15
903 Jefferson goblet, H (2 each)	20
1170 Pleat and Panel luncheon goblet (2 each)	10
1170 Pleat and Panel cruet	15
1183 Revere individual salt (4 each)	12
1184 Yeoman cocktail, H	10
1225 Plain Band table sugar lid	15
1401 Empress plate, 8" sq, 448 Old Colony, Sahara, H (4 each)	15
1404 Ipswich sherbet (2 each)	10
1469 Ridgeleigh goblet	10
1483 Stanhope cream/sugar, no knobs, H	30
1483 Stanhope cup, no knob (6 each)	15
1503 Crystolite shell mayonnaise	10
1503 Crystolite cruet	15
1509 Queen Ann DF floral bowl	25
1509 Queen Ann DF creamer	5
1509 Queen Ann Cup/saucer, H	5
1509 Queen Ann 10 ½" dinner plate	15
1519 Waverly pickle/olive	10
1519 Waverly 12" celery, H	5
1519 Waverly triplex relish	10
1519 Waverly 10" deep salad bowl	15
1519 Waverly twin dressing, H	15
1519 Waverly 6" plate (4 each)	5
1519 Waverly 8" plate (3 each)	5
1519 Waverly violet vase, H	20
3350 Wabash plate, 6", Flamingo (4 each)	5
3440 Portsmouth goblet, Moongleam ft (3 each)	20
4085 Kohinoor oyster cocktail (5 each)	5
4085 Kohinoor sherbet (3 each)	5
4085 Kohinoor ftd soda, 10 oz	5
4182 Thin plate, 8" DO, Moongleam	10
5082 Mid Century sherbet, H, paper label (2 each)	10

Kim Carlisle
28220 Lamong Rd.
Sheridan, IN 46069

P&I \$6.00 all orders
317-758-5767
kcarlisl@att.net

4026 decanter with Pied Piper etch	\$200
4027 Christos decanter, Flamingo w/crystal cut stopper	300
105 Pembroke 7" candelabrum, Flamingo, pr	350
42 Orchid etch salt and pepper metal tops, pr	300
4027 Christos decanter with Moongleam ft. & stopper	375
1428 Warwick 9" horn of plenty, Moongleam	850
1404 Old Sandwich oil & No. 85 stopper, Moongleam	450
1404 Old Sandwich oil & No. 85 stopper, Flamingo	650
4045 Ball 6" vase with Mermaid etch	650
1280 Winged Scroll ring tree, Emerald	1500
1404 Old Sandwich basket	750
1567 Plantation water pitcher with Ivy etch	395
1567 Plantation candy box and cover Ivy etch	850
1567 Plantation goblet with 4 Pineapples around bowl	2500
4225 Cobel 1 qt. cocktail shaker with Sportsman etch	150
1404 Old Sandwich catsup bottle, Moongleam	650
2125 Cobel 1 qt. cocktail shaker with Orchid etch	175
4057 Cecelia 10 1/2" vase, optic, Limelight	450
1506 Provincial 5 1/2" ftd candy jar/cover, Limelight	375
5089 Princess 10 oz. goblets with Orchid etch (2 each)	150
3397 Gascony decanter, Sahara with crystal st & ft	425
1567 Plantation salt & pepper, no Pineapples elaborate cutting	325
1567 Plantation 9 1/2" vase	275
1420 Tulip vase Sahara with elaborate cutting	750
433 Greek Key 2 qt. crushed fruit and cover	450
4163 Whaley beer mug with Sahara hdl & Chintz etch	325
3390 Carcassone decanter & stopper Sahara	375
1 Georgian 9" candlesticks, pr	100
3 Marlboro 9" candlesticks, pr	250
433 Greek Key straw jar with original cover	1500
110 Sandwich Dolphin 10" candlesticks, Flamingo, pr	650
109 Petticoat Dolphin single candlestick, Moongleam	200
107 Wellington 10" single candlestick, Moongleam	225
433 Greek Key 21" punch bowl underplate, non-fill bubble on edge	1250
4209 Oval 9 1/2" vase with #1 Sport etching, Flamingo	1250
4192 1/2 9" vase with Orchid etch	850
1 Dinky Do (Minuet Girl)	450
1121 Octagon individual salt, marked	65
2401 Oakwood decanter with Sportsman etch	150
1252 Twist mustard, cover, spoon, underplate all Sahara	225
1401 Empress D.F. candleholders, Moongleam, pr	450
1401 Empress D.F. candleholders, Flamingo, pr	350
1509 Queen Ann dinner plates w/Minuet etch (4 each)	150
1404 Old Sandwich candlesticks, Moongleam, pr	450
1519 Waverly dinner plates with Rose etch (12 each)	175
1447 Rococo 6 in. comport, Sahara	650
101 Tropical Fish 12"	2500
1280 Winged Scroll 11" dresser tray, Emerald	275
1280 Winged Scroll cologne, Emerald	550
21 Aristocrat electroportable 9" lamp w/#1 Lance cutting, glass spider with "C" prisms	950
305 Puntty and Diamond Point water bottle	125
1567 Plantation 8 1/2" plates w/Ivy etch (8 etch)	120
4229 Favor vase Cobalt	265
4228 Favor vase Sahara	225
4228 Favor vase Crystal	225
4231 Favor vase Sahara	250
1469 2 Ridgeleigh 4 oz. colognes/105 stoppers pr.	150

◆ Paid Ad

Wanted: 3357 King Arthur footed ice tea glasses, Moongleam stem/foot and clear bowl. Contact: monairvine@earthlink.net or 616-866-0355

◆ Paid Ad

For Sale: Heisey Rose etch collection, approximately 350 pieces. Please call 479-452-0943 or e-mail ParsonsSkeeter51@aol.com.

◆ Paid Ad

March 28th & 29th 2009

**Coming to Chicagoland,
The Largest-36th Annual Elegant
& Depression Glass Show.
See all the Colors & Patterns,
Own a Piece of American History!**

Sponsored by
The 20-30-40 Glass Society of Illinois
P.O. Box 858, La Grange Illinois 60525
Website: WWW.20-30-40society.org

March 28th & 29th 2009

Saturday 9 am - 5 pm

Concord Plaza

401 West Lake St.

Sunday 10 am - 4 pm

Midwest Conference Center

Northlake, Illinois 60164

Admission \$8.00 Per Person
\$7.00 with this card - Limit 2
Free Parking with shuttle bus to front door
Crystal Repair; Glass Identification; Reference Library; Door Prizes.
All attendees will be processed as associate members for this event.

◆ Reciprocal Ad

Find the Best of Heisey Glass...

...with popular patterns like Orchid, Heisey Rose, Minuet, and hundreds more. We also carry other fine crystal and depression glass from Cambridge, Fostoria, Imperial, Duncan & Miller, and more. The world's largest supplier of old and new china, crystal, flatware and collectibles, Replacements, Ltd. carries over 11 million pieces in inventory in over 250,000 patterns.

If you're looking to add to your collection, or if you're looking to sell — call us toll-free. We're always looking for more.



REPLACEMENTS, LTD.

China, Crystal & Silver • Old & New

Dept. HS, PO Box 26029, Greensboro, NC 27420

www.replacements.com

1-800-REPLACE (1-800-737-5223)

◆ Paid Ad

Dealer Directory

Maximum 6 lines/12 months/\$35 MEMBERS ONLY

Contact the Editor to place your ad!



<p>KIM & PAM CARLISLE SHOWS & MAILORDERS ONLY 28220 Lamong Rd. Dept. H Sheridan, IN 46069 Glass Cleaning Services Available (317) 758-5767 kcarlisl@worldnet.att.net</p>	<p>SHIRLEY EUGENIA DUNBAR Heisey a Specialty—Mail Order, Shows, Appraisals EMAIL: shirley400@aol.com PO Box 8344, Port St. Lucie, FL 34952 Oct-May (772) 337-1558 PO Box 222, Naples, ME 04055 May-Oct (207) 647-5652</p>	<p>SUM OF LIFE Elaine Husted: 610-469-1243 Traveling through eastern PA Call, stop in, be a buyer or a browser!! E-mail: 1classycat@comcast.net</p>
<p>ALL HEISEY AUCTION Consignments Welcome Apple Tree Auction Center 1616 W. Church, Newark, OH 43055 (740) 344-4282</p>	<p>MOUNDBUILDERS SECOND GENERATION Barbara and Richard Bartlett Heisey Exclusively! 1-904-280-0450 PO Box 1931, Ponte Vedra Beach, FL 32082 Toll Free 1-888-434-7397(HEISEYS) EMAIL: CLASYGLAS2@AOL.COM</p>	<p>EAGLES REST ANTIQUES <i>Buying Heisey, China & Pottery</i> Carl and Mary Evans 62 Fieldpoint Rd., Heath, OH 43056 (740) 522-2035</p>
<p>PAULA & JEFF MORROW Elegant Glassware and American Dinnerware 126 Clinton Avenue Elmhurst, IL 60126 (630) 833-4644 mor-fab@comcast.net</p>	<p>H & R DIAMOND H Helen & Bob Rarey 1450 White Ash Dr. Columbus, OH 43204 (614) 279-0390 after 5:30</p>	<p>CRYSTAL LADY Bill, Joann & Marcie Hagerty Specializing in elegant depression glassware 1817 Vinton St., Omaha, NE 68108 Shop (402) 341-0643 or Home (402) 391-6730 Email: ejhagerty@aol.com website:www.crystalladyantiques.co</p>
<p>REALMS IN GLASS Roy Eggert Heisey Custom Stained Glass 12009 Fingerboard Rd, Monrovia, MD 21770 301-865-5196 roy54@hughes.net</p>	<p>PIECE BY PIECE ANTIQUES Buy & Sell Specializing in Heisey Glassware Bryan K. Baker Fairfax Station, VA 22039 Newark, OH 43055 (703) 250-6117 piecebypiece@verizon.net</p>	<p>PATTON HOUSE ANTIQUES Specializing in Glass*Heisey*Cambridge*Fostoria*Duncan* Factory Antique Mall, Verona, VA off I-81 Exit 227 Antiquers Mall, Booth 81, Rt. 29 N., Charlottesville, VA The Daniels, Box 547, Louisa, VA 23093 (540) 967-1181</p>
<p>C&J ANTIQUES Cole & Jean Miesner Box 45, 72 Whig St. Newark Valley, NY 13811 (607) 642-9905</p>	<p>SIBYLS OF WILMINGTON Sibyl & Ned Lavengood at Castle Corner Antiques 555 Castle St. Wilmington, NC (910) 264-9597 or Sibylsantiques@bellsouth.net</p>	<p>FRAN'S FANCY FINDS Fran & Jack Grenzebach 10534 Valencia Rd., Seminole, FL 33772-7511 (727) 391-5184 SHOWS MAIL ORDERS</p>
<p>The American Bell Association P.O. Box 19443 Indianapolis, IN 46219-0443 www.americanbell.org m</p>	<p>PASTICHE ANTIQUES at Preston's Antique Gaslight Village US 12, Allen, MI 49227 Elegant Glass and Other Fine Antiques pasticheantiques@gmail.com</p>	<p>WILLEY'S ANTIQUES & MUSEUM Specializing in Heisey 11110 Cannon Rd., Frazeytsburg, OH 43822 16 miles east of Newark, OH (740) 828-2557</p>
<p>CHARLES & MILDRED FISHER Heisey animals and Heisey By Imperial animals 1607 Dayton Rd, Newark, OH 43055 Cfisher08@roadrunner.com (740) 281-3104</p>	<p>MARSH'S ANTIQUES Dick and Virginia Marsh 4532 Newton Road Newark, OH 43055 swamp@alink.com (740) 366-5608</p>	<p>MOONGLEAM ANTIQUES Heisey Glassware & American Art Pottery John Woytowicz and Peter Rivard 70 Pleasant St., Gardiner, ME 04345 (207) 582-9048 E-mail: jmwpwr@aol.com</p>
<p>ROBERT M. LOCH Voting Member HCA and NWHC Pacific Interstate Glassware Co. PO BOX 469 Custer, WA 98240 360-366-3166</p>	<p>CRESTONE MANOR UNIQUES Harold & Loleta Hammontree 3317 Crestone Circle, Chattanooga, TN 37411 423-629-1274 hammonl@bellsouth.net Heisey Only</p>	<p>APPLE VALLEY COLLECTIBLES Richard & Marilyn Garnett – Owners Shows/ Mail Order (845) 691-6308 Email: diamondH95@aol.com</p>
<p>DOWNSTAIRS AT FELTON ANTIQUES 100B Felton St, Waltham, MA 02453 781-894-2223 info@feltonstreetantiques.com GLASSWARE, POTTERY, EPHEMERA, STERLING, FURNITURE FROM EVERY DECADE!</p>	<p>WM GLASS Bill & Mary Barker 400 Nantucket Ave., Pickerington, OH 43147 (740) 927-0918 mcbarker@embarqmail.com Heisey Only</p>	<p>WATERSEdge ANTIQUES Norene & Don Walzer Shows & Mail Order 25089 Riverwalk Drive Leesburg, FL 34748 (352) 314-8975 dnnwalzer@embarqmail.com</p>
<p>JERRYS' ANTIQUES Shows Only Glassware and Other Fine Collectables PO Box 4485, Davenport, IA 52808 563-340-1871 jerrysantiques@mchsi.com</p>	<p>ONCE AND FUTURE ANTIQUES Susan & Stephen Pescatore 9 Donna Rd. Chelmsford, MA 01824 (978) 256-5418 Heisey and Elegant Glass</p>	<p>BOB & MARY KREIMER Specializing in Heisey Glass 7044 SW 116th Loop, Ocala, FL 34476 (352) 873-8306 email: rkreimer@earthlink.net. Shows and Mail Orders Only</p>
<p>J & L TREASURES Specializing in Heisey, Cambridge, Fostoria, Tiffin, Morgantown, etc Linda Kilburn, PO Box 1257, Burlington, CT 860-673-4088 jltreasures@comcast.net</p>	<p>Charlene Bowman Shows Only Heisey – Cambridge – Fostoria - Morgantown P.O Box 287, Clarksville, OH 45113 937-289-2114 twoclbs@aol.com</p>	<p>YELLOW BRICK ROAD ANTIQUES Jean Will Leavenworth, KS 66048 (913) 682-4831 Specializing in Heisey and Elegant Glassware Shows and Estate Sales</p>
<p>Just in Time Antique Mini Mall 29 North Third St Newark, OH 43055 Heisey in Stock 740-349-0001 ntleblanc@aol.com</p>	<p><i>Your Ad Could be Here</i></p>	<p><i>Your Ad Could be Here</i></p>

When Renewing Your Membership

Help ensure the future of your Museum. When you renew your membership at one of the levels below, any amount beyond the regular Associate dues goes into the Endowment Fund.

<i>Individual Contributing, one person in household</i>	<i>\$50</i>
<i>Joint Contributing, two people in one household</i>	<i>\$60</i>
<i>Family Contributing, parents and children under 18</i>	<i>\$75</i>
<i>Patron</i>	<i>\$125</i>
<i>Sponsor</i>	<i>\$250</i>
<i>Benefactor</i>	<i>\$500</i>

Visit The
National
Heisey
Glass
Museum



Come at your leisure to enjoy more than 4,800 pieces of glassware produced by A.H. Heisey and Company from 1896-1957. Hundreds of patterns are featured in all production colors. Rare and experimental items are included as well.

Facilities are air-conditioned and handicapped-accessible. Hours are 10:00 a.m. to 4:00 p.m. Tuesday through Saturday, 1:00 to 4:00 p.m. Sunday (except Jan. and Feb.). Members are admitted free, regular admission is \$4. Office hours are 8:00 a.m. to 4:30 p.m. weekdays.

Membership Renewal Notice: Check the date above your name and address on the mailing label. This is your expiration date. If it reads 3-10-09, make sure your dues are paid soon in order to receive next month's issue of *Heisey News*.

Contact the HCA Administrative Office at (740) 345-2932 for more information. The Endowment Committee wishes to thank those who have become Endowment Members and all of the individuals and study clubs that have so generously supported the HCA Endowment Fund. All members who have supported the fund are recognized each year in the February issue of the Newsletter. Your support will make the Museum self-sustaining in the years to come. Thank You all! ♦

Shipping & Handling Fees for Outside US

Additional shipping charges are required for members living outside the U.S. Current rates are Canada, \$22; for other countries, contact the Museum. Rates are subject to change at any time due to rate changes made by the US Postal Service. To verify current rates, call (740) 345-2932 or E-mail business@HeiseyMuseum.org

Museum Volunteers for January 2009

Bryan Baker
Chuck & Amy Jo Jones
Dick Marsh
Jack Metcalf
Don & Pat Moore
Russ Reopell
Judy Rhoads
Dick & Marilyn Smith
Dave & Mary Ann Spahr
Charlie Wade



Periodical Postage

Paid at the Post Office
In Newark, OH 43055
Publication # 00986
POSTMASTER SEND FORM 3579 TO:
HCA
169 W. Church St.
Newark, OH 43055

To: _____