

# HEISEY NEWS

The Official Publication of Heisey Collectors of America, Inc.

Volume XXXVIII No. 1

January 2009

ISSN 0731-8014

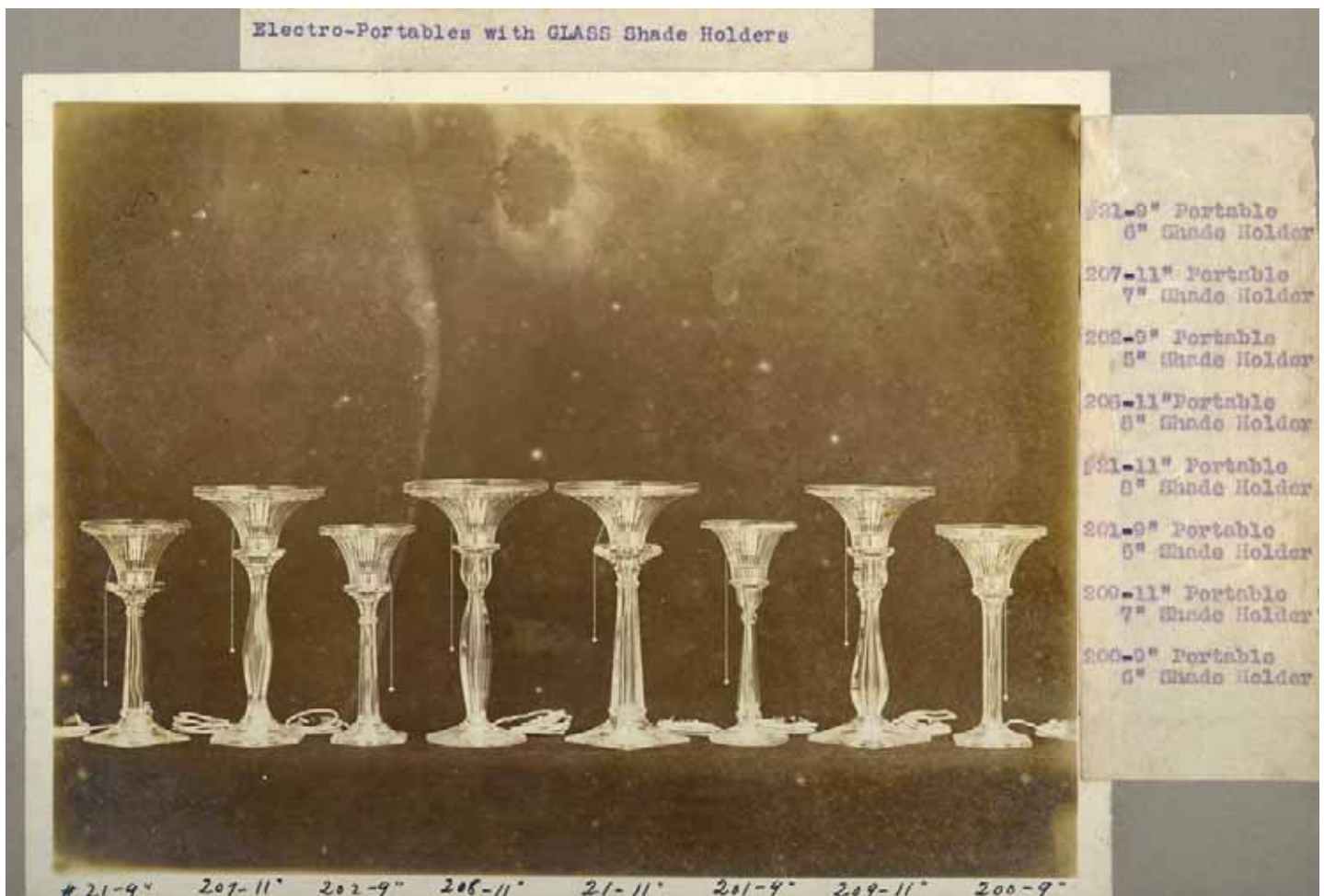

Original Heisey Display Piece Showing Electro-Portable Lamp Bases With Glass Shade Holders  
From Left to Right: 21 Aristocrat (9", 6" shade holder), 207 Patrician (11", 7" holder),  
202 Federal (9", 5" holder), 208 Sanford (11", 8" holder), 21 Aristocrat (11", 8" holder),  
201 Windsor (9", 5" holder), 209 Regal (11", 7" holder), 200 Classic (9", 6" shade holder)

For Story and Additional Pictures See Page 5

## HEISEY NEWS

Heisey Collectors of America, Inc.  
169 West Church Street  
Newark, Ohio 43055  
Phone 740-345-2932 Fax 740-345-9638  
Web Site: [www.heiseyMuseum.org](http://www.heiseyMuseum.org)  
All Rights Reserved 2009  
ISSN 0731-8014

### Staff and Phone Extensions

Curator, Walter Ludwig, [curator@heiseyMuseum.org](mailto:curator@heiseyMuseum.org), Ext. 4  
Business Manager, Shelly Hoberg, [business@heiseyMuseum.org](mailto:business@heiseyMuseum.org), Ext. 2  
Clerks, Justin Church, Amanda McDonald  
[membership@heiseyMuseum.org](mailto:membership@heiseyMuseum.org), Ext. 1  
Gift Shop, Ext. 5

### HCA Board of Directors:

**President**, Bryan Baker - Fairfax Station, VA, 703-250-6117 –  
[hcapresident@heiseyMuseum.org](mailto:hcapresident@heiseyMuseum.org)  
**Vice-President**, Charlie Wade – Newark, OH 740-587-2002  
**Secretary**, Amy Jo Jones - Beavercreek, OH, 937-426-1567  
**Treasurer**, Sharon Orienter – Rochester, NY, 585-288-8076  
Member-at-Large, Dave Spahr - Xenia, OH, 937-372-7166

Sid Edwards – Tallassee, AL, 334-283-4663  
Tom Files – Kansas City, MO, 816-468-7087  
Ron Keener – Heath, OH, 740-323-3747  
Sue Kilgore – Kalamazoo, MI, 269-345-3990  
Robert Loch – Custer, WA, 360-366-3166  
Jack Metcalf – Utica, OH, 740-892-2664  
Karen Taylo – New Bern, NC, 252-637-9985

HEISEY NEWS is published and printed monthly (twice in March), by Heisey Collectors of America, Inc. (HCA). Periodical postage paid at Newark. Subscription is limited to HCA members. First class mailing is available for an extra \$20.00, due with payment of membership. If you are having difficulty receiving your Newsletter, please contact the HCA Administrative Office Monday through Friday 8:30 a.m. - 4:30 p.m.

The opinions expressed in articles in HEISEY NEWS are those of the authors and not necessarily those of the organization. The Editorial Staff reserves the right to edit, with or without the consent of the author or to refuse any material submitted for publication.

### Back Issues

Back Issues available from files are \$3.00 per issue plus shipping and handling

### Advertising

Ads may be mailed to: HCA Advertising, 169 W. Church St., Newark, OH 43055; faxed to (740) 345-9638; or e-mailed to [curator@HeiseyMuseum.org](mailto:curator@HeiseyMuseum.org). Whenever possible, please e-mail your ad. Always include your MasterCard or Visa number and expiration date. When mailed or faxed, ads should be typed or printed on white paper with dark ink. Camera ready ads are accepted, but must follow line specifications outlined at the beginning of the advertising section. Ads containing reproductions will not knowingly be accepted unless clearly stated (e.g. Heisey by Imperial, etc.). HEISEY NEWS accepts no further liability. In the event of a typographical error, the incorrect portion of the ad will be run in the following issue, but HEISEY NEWS assumes no further liability. See advertising section for rates and deadlines.

### Museum

Heisey Collectors of America, Inc., a non-profit corporation (tax-exempt status), owns and operates The National Heisey Glass Museum in Veterans Park, 6th and Church Streets, Newark, Ohio. Open year round, Tuesday through Saturday 10:00 a.m. – 4:00 p.m., Sunday 1:00 – 4:00 p.m. (except Jan. and Feb.), closed holidays. Other hours by appointment. Members admitted free.

### Identification

HCA will attempt to identify unknown glass items. Send a color photograph, measurements, and a self-addressed, stamped envelope to the attention of the Curator. Other arrangements should be made in advance with the Museum staff. Please keep in mind that the Museum cannot appraise items. Identification is free to members, non-members \$5.00 per item.

### Membership

To join Heisey Collectors of America or to renew your membership, contact the HCA Administrative Office Monday through Friday 8:00 a.m. - 4:30 p.m. Eastern Time. Associate dues are \$30.00 plus \$5.00 for each additional household member. Voting members pay an additional one-time fee of \$25.00. Please consider supporting the Endowment Fund by joining at one of the levels listed on the back page.

### Museum Gift Shop

There is always someone in the Gift Shop during the Museum's hours of operation to help answer questions or take orders. When ordering by phone, please have a credit card ready. When ordering by mail, please be sure to include appropriate charges such as shipping and sales tax. Please note that the HCA member discount does not apply to original Heisey or special project items.

### Shipping and Receiving

Delivery is made much easier when we have a complete street address, not a PO Box. We prefer to use UPS. If you have not received a package, please call the Administrative Office to confirm it was sent. We will assist you in tracing it. If your package arrives damaged, please contact your local UPS representative. We insure everything.

### Donations and Loans to the Museum

If you would like to make a donation to the Museum or have questions regarding items on loan, contact the Curator. HCA reserves the right to accept or refuse items based on current holdings.

## HEISEY CALENDAR OF EVENTS

### 2009

HCA Benefit Auction	April 17-18
Heisey National Convention and Elegant Glass Show Newark, OH	June 17-20

### Table of Contents

Heisey Electro-Portable Lamps, Walter Ludwig	FC & 5-8
Heisey Calendar of Events	2
Message from the President, Bryan Baker	3
Curator's Report, Walter Ludwig	3-4
HCA Welcomes New Members for November 2008	4
1776 Kalonyal Pattern, Joe Lokay	8-12
2009 All Heisey Benefit Auction, Dave Spahr	12
2009 Benefit Auction Contract	13-14
2009 HCA Benefit Auction Consignor Packing List	15
Heisey Glass Museum Playing Cards, Order Form (Green Deck)	16
Approved 2009 HCA Budget	17
HCA 2009 Budget, Sharon Orienter, Treasurer	18
2009 Heisey Convention "Artistry in Glass: The Heisey Etchings" Judy Rhoads and Mary Ann Spahr, Co-Chairs	19
A Way to Help HCA, HCA Endowment Committee	19
Places to Stay in the Newark Area, Walter Ludwig	20
Index for Heisey News Volume XXXVII 2008, Joe Lokay	21-22
Holiday Holdback Silent Auction Results, December 12, 2008	22
Cookie Donators for Open House	22
Study Club Directory	23
Club Notes	24-25
Open House – 2008 (Pictures)	25
Advertising Guidelines	26
Classified Ads	26
Dealer Directory	27
Museum Volunteers for November 2008	BC

## MESSAGE FROM THE PRESIDENT

Bryan Baker

Happy New Year! Here we are at the beginning of a new year - where does time go? Our Holiday Open House in December was another success for our Museum. Kids and grownups alike enjoyed the decorations, cookies, crafts, and yes - Heisey! As always, the Museum takes on a magical look and feel when adorned with decorations of the Season. An added treat for our open house was the lovely harp music played live in the King House. Our very own harpist, Mary Ann Spahr, entertained all with her talented playing - what a thrill it was. HCA has quite the talent pool!

I want to thank our chairs, Kathy Smith and Mary Ann Spahr, our staff, and countless volunteers for all they did in making our Open House a joy and success for all. See you next year!

In December, the board of directors met and approved the operating budget for the upcoming year. Thanks to the diligence of all involved, we were able to reduce our budget expenses this operating year. As all are well aware, the economic news continues to be troublesome - the Museum is not immune from the affects we all are feeling. Your continued support, whenever and wherever possible, is always needed and appreciated.

As you are reading this Newsletter, preparations are under way for our annual Benefit Auction to be held in April. Cataloging of the glass will take place this month - you still have time to consign glass for this all-important fund-raiser for HCA. Please contact Dave Spahr or Walter Ludwig for information - cutoff for consignments is the 15<sup>th</sup> of this month. Perhaps now is the time to make a little room in your collection for those new additions you may have received over the Holidays!

On a more serious note; on December 11, our Business Manager Shelly Hoberg's husband, Jimmy, was in a very serious automobile accident

in Columbus, OH. Jimmy was critically injured and has undergone more than one surgery. Please keep the Hoberg family in your thoughts and prayers as Jimmy progresses through what will be a very long recovery. A fund has been set up at Park National Bank to accept donations to aid the family.

May you all have a safe and prosperous New Year. I remain confident that by working together, we will continue to make our Museum and organization a strong and viable presence in the community, both locally and nationally.

Until next time,

Bryan Baker ♦

## CURATOR'S REPORT

Walter Ludwig

We are now officially an icebox here in central Ohio. The temperature this morning dipped down into the single digits and the wind chill had that ugly minus sign in front of it. If you ask me, it is time to bundle up and hibernate for a couple of months. Those bears definitely have a good idea. But, unfortunately, there is work to be done here at the Museum, so I better get to it.

In December, I changed the display that the Museum has at the Midland Theater which is located right on the square in downtown Newark. This great old theater has been lovingly restored and provides a great venue for entertainments that visit Newark to perform in. The Museum has long had a display case in the lobby of the theater that allows us to promote the Museum. I mount about three different displays there a year. This time I have used only Heisey Emerald glass with a few pieces of Ruby stained Heisey to accent. It actually makes a great statement for the holidays. The display will be there through March (taking advantage of Valentine Day and St. Patrick's Day), so please stop in and take a look. The lobby is open during the day for ticket sales, so it will not be a problem.

The Museum and HCA has gotten some excellent publicity in the last month. Tom Files spoke with a reporter at the Antiques Trader and an article was published in the December 3 edition. You should be able to read the article on the Antique Trader web site. The title of the article is "A Cut Above: Exquisite Brilliant Heisey Glass."

Also, in December, our own Tanner Temnick got featured on the MTV show "Made." Tanner joined HCA when he was six years old and is now a junior in high school. He continues to volunteer at the Museum. A film crew was here in Newark as a break dance artist taught Tanner the ins and outs of the craft. One interview was held in Tanner's bedroom where his Heisey collection was much in evidence. The break dancer asked him about the pieces and he talked at length about his favorite Heisey glass pieces. The episode can be viewed on the MTV web site.

Finally, I have been working with a free-lance writer for a couple months on an article she has been writing on the 1567 Plantation pattern for the "Cooking with Paula Deen" magazine. That article will appear in the January/February issue of that magazine. The article will focus on the pattern and the way that it reflects southern hospitality. Do look for the magazine on your newsstands.

All of this publicity is very good for the Museum. This is our slow time of year, so if it encourages a few extra visitors, they will be more than welcomed here.

The Holiday Open House was a huge success for the Museum. Besides the children during the day, we saw a lot of new faces visit us during the evening hours when the Sherwood Davidson House (our neighbor and the location of the Licking County Historical Society's museum) was open. Because the weather was cooperating this year we were able to put luminaries up the path of the Museum and it looked especially beautiful to welcome our visitors. You can see a few pictures from the event on page 25 of this Newsletter.

The deadline for getting glass in for the Benefit Auction is fast approaching. We have gotten a few really outstanding items which I really can not talk about until we actually do the cataloging at the end of January. Given the way that Heisey people procrastinate, I am hoping for a big surge in deliveries at the beginning of the year. This event is so crucial for keeping the Museum going all year long.

I am happy to say that I have gotten one more Heisey promotional brochure that I will be able to feature next month. This brochure will be on the 1072 Southwind cutting. Any original promotional material that the company produces is so valuable to the Museum and forms a very important component of our Archives. If you are aware of any additional material out there, please let the Museum know. I love sharing this information with all of our members.

Next month, we will be listing all of the voting members of HCA. If you would like to become a voting member, you only need to pay a one time fee of \$25 and then your voting status will be assured as long as you are a member of HCA.

I hope that Santa was good to you and left some great pieces of Heisey under the tree. Of course, you can always be good to yourself and treat yourself to a choice piece of Heisey at the local auction house or antique mall. There are plenty of bargains to be had; all you have to do is root them out. So get in the car and go for a drive that might take you by a store or mall that has a piece for you waiting there on their shelves. It will not find you; you need to find it yourself. ♦

**HCA WELCOMES  
NEW MEMBERS  
FOR  
November 2008**

Jerry Gartner, OH  
Douglas and Donna Sites, MD



# HEISEY ELECTRO-PORTABLE LAMPS

Walter Ludwig

My great helpers in the Archives are Chuck and Amy Jo Jones. Whenever they are in town they spend a couple hours up there arranging and digging around. Recently, Chuck brought me the pictures that accompany this article.

The pictures are mounted on heavy posterboard and the captions have been pasted on. Three of the pictures were taken with a black background, but the others made use of a background that resembles a starry night sky. The pictures are in black and white. These must have been used by the company to promote their line of electro-portable lamps. All but one model are shown in the pictures. The pictures probably date to about 1915 when the last of the pictured models was introduced and before the missing model was introduced in 1917.

In June of 1913, A. H. Heisey & Company filed one design patent and four invention patents on a new innovation in lighting. The idea was to use a Heisey colonial style candlestick as the base of an electric lamp. The key patent was 1,222,676 which claimed the innovation of the "adaptation of a candlestick into an electric lamp by blowing a longitudinal passage through the center of the column and out to the side or rear in a manner that would not detract from the ornamental

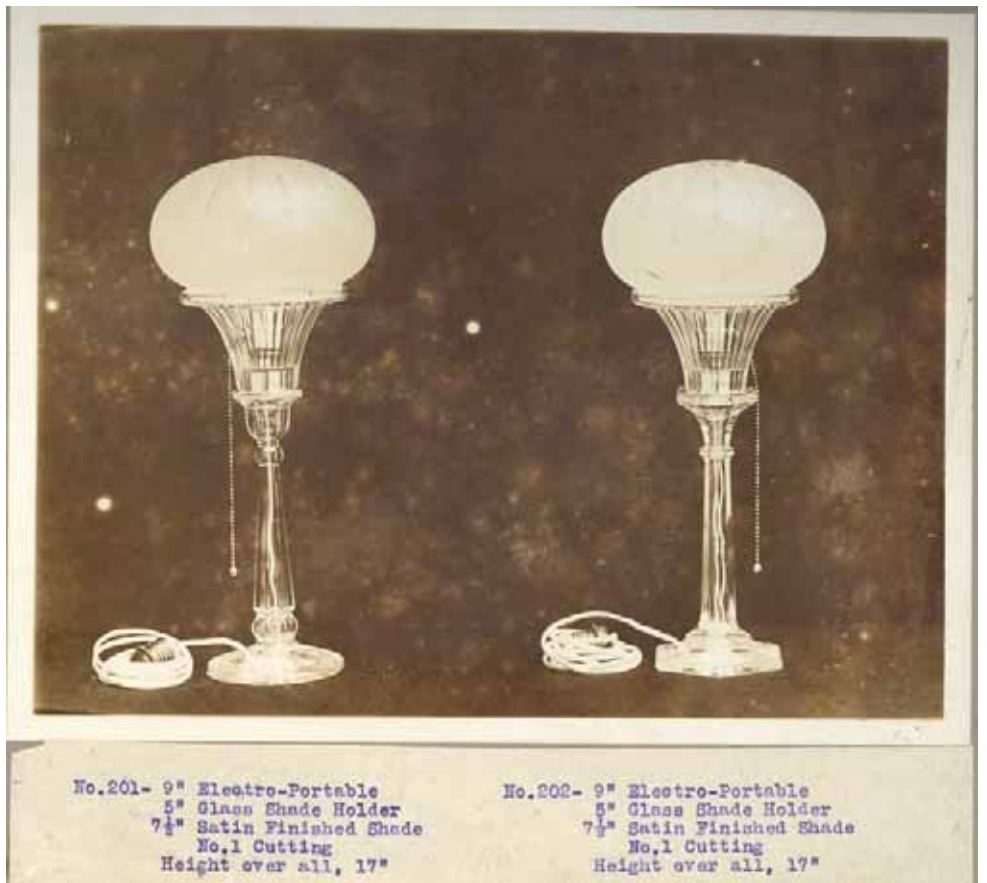

appearance of the candlestick." The patent emphasized the economy of manufacture of this new electric candlestick, since forming the candlestick itself and blowing the passage through it could be done in "substantially simultaneous or quickly successive operation, while the candlestick is still within the mold." The other invention patents covered the actual method with which this was accomplished.

In 1914, one further patent was applied for that covered the glass shade holder which rested on the electro-portable base, "which could be held securely in place by the socket for the electric bulb and which would, in turn, serve as a support for a glass shade or globe. The shade holder would also "provide a simple means for suspending prisms from the glass member, which give a pleasing effect to the lamp."

The 9" 21 Aristocrat electro-portable lamp was the first one to be made in November of 1913. The 11" size followed in December of that year. The 9" 21 Aristocrat was in production for the longest period of time being made until 1929 and then revived in 1939 for a one year period. The 21 Aristocrat was the only lamp that was made in more than one size. In 1917 a 15" version of the lamp was also introduced but it had the shortest production period, only lasting until 1922. The 9" is also the only electro-portable that was offered in color. In

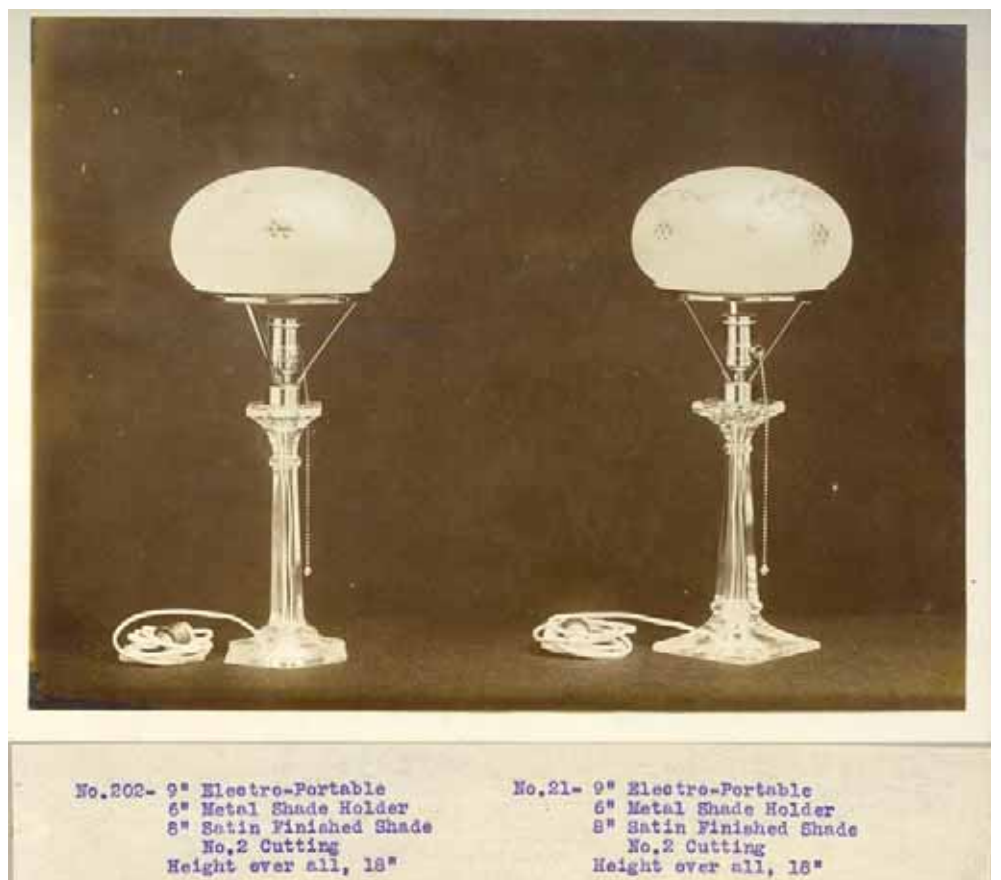
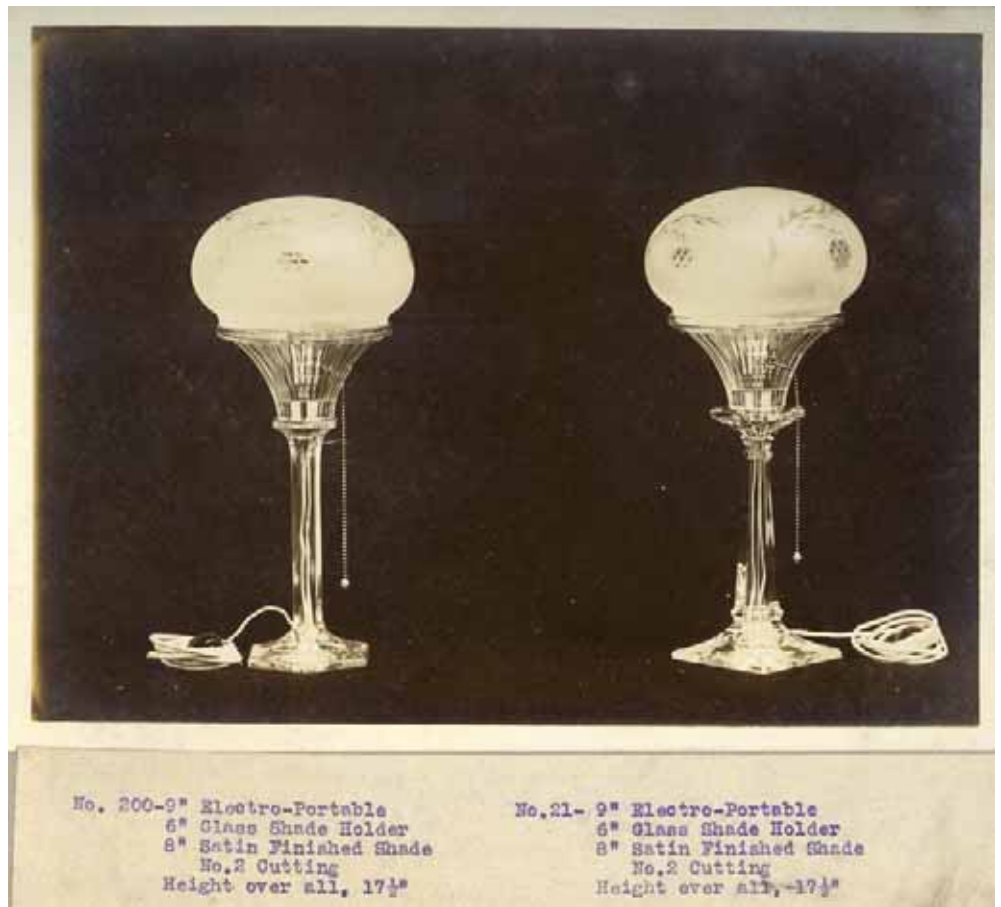



January of 1926 a half turn each was made in Moongleam and Flamingo. It is not known if more were made, but we do know that both of the color examples are very hard to find today.

In 1915, the electro-portables were expanded to include six additional bases all based on candlesticks that Heisey had in production at that time. Rather than, as with the 21 Aristocrat, use the same pattern number for the candlestick and the lamp, each of these lamps were assigned a different pattern number from the number of the corresponding candlestick. This was probably done to facilitate orders for these lamps and to avoid confusion. The new lamps were the 9" 200 Classic based on the 16 Classic candlestick, the 9" 201 Windsor based on the 22 Windsor candlestick, the 9" 202 Federal based on the 25 Federal candlestick, the 11" 207 Patrician based on the 5 Patrician candlestick, the 11" 208 Sanford based on the 29 Sanford candlestick, and the 11" 209 Regal based on the 47 Regal candlestick.

All of the electro-portable lamps could be purchased with a variety of fittings. There were two wire shade holders (No. 2 and No. 3) for silk shades. There was a choice between a metal spider and a glass spider to hold up the glass shades that surmounted the lamps. The 9" lamp bases took either the 5" or 6" glass or metal holder which would support either a 7 1/2" or 8" shade. The taller bases took either the 7" or 8" glass or metal holder



supporting a 9" or 10" shade. The smaller 7 1/2" and 8" shades were offered either plain or with 1 Lance cutting or 2 Floral cutting. The larger 9" and 10" shades were offered plain or with 3 Pinwheel cutting or 4 Feather and Star cutting. The 9" 21 Aristocrat and 9" 201 Windsor were also offered with the 4050 6" shade plain or with 861 Neopolitan cutting. This arrangement came with a bobèche and prisms rather than a spider.

Heisey's line of electro-portable lamps were a big success for the company and were readily accepted by the buying public. Although most models were eliminated in 1922, the 9" 21 Aristocrat was still in production in 1929. The 201 Windsor was revived in 1936, the 9" 21 Aristocrat in 1939, and the 11" 209 Regal in 1940.

Much of the material for this article was taken from "Heisey Candlesticks, Candelabra, and Lamps" by Tom Felt and Bob O'Grady. ♦

## 1776 KALONYAL PATTERN

Joe Lokay



1776 Kalonyal, from Vogel I, Page 25C

Production of the 1776 Kalonyal pattern started in about 1905. This is one of the few early patterns that A. H. Heisey & Company named. This pattern was shown as a new pattern in January 1906. However, an application for a design patent for this pattern was filed on September 24, 1904. It was granted on November 1, 1904, and given design patent no. 37,203. Was the name and pattern number used to commemorate the freedom for the 13 colonies? That is hard to determine. We know that 1906 was only the 130<sup>th</sup> year since July 4, 1776. That is not one of the big anniversaries that are usually noted. Anyway, the pattern had a very short life as it appeared in only one company price list, Price List #120 circa 1906. Production appears to have been from 1905 to 1907, a span of about three years.

The pattern design is a simple colonial design with its scallops, arches, and panels. Except within each panel is a raised jewel-like panel which is the identifying feature for this pattern. It was made in crystal only and you will find most pieces signed with the Diamond H. Occasionally a piece with gold or ruby decoration will turn up.

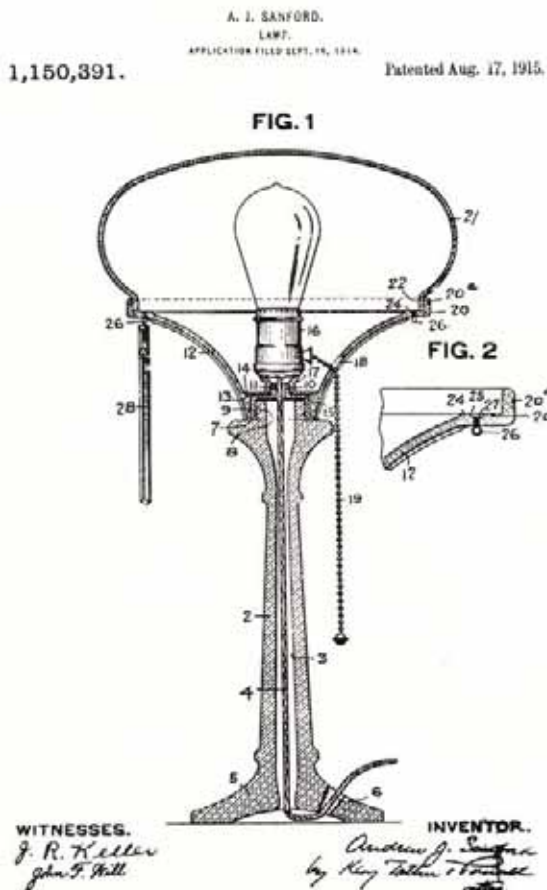

Illustration of Electro-Portable Lamp from Patent Application



Kalonyal was a very large pattern. There were 110 items offered in Heisey Price List #120. I have divided these items into two categories, tableware and stemware. There are 85 items in the tableware category and 25 items in the stemware category. Most of the stemware was offered in two styles, straight or flared. In the tableware category, there was a table set, 22 nappies, 6 plates, 6 jellies, 8 bowls, 6 punch bowls, 6 oils, and more. Not listed with the other pieces of 1776 Kalonyal in Price List #120 are a 9" candlestick and three candelabra. Instead, these are listed in the section with other candlesticks and candelabra.

There were not 110 separate molds to produce the items in this pattern. Instead, one mold might be used to produce several variations on the same piece. Thus, both a straight and flared goblet would come from the same mold. Also several variations of nappies might come from one mold.

#### Production of 1776 Kalonyal:

##### Tableware Items

1. spoon
2. cream
3. sugar and cover
4. butter and cover
5. nappy, 4 ½"
6. nappy, 5"
7. nappy, 6"
8. nappy, 7"
9. nappy, 8"
10. nappy, 9"
11. nappy, 7", flared
12. nappy, 8", flared
13. nappy, 9", flared
14. nappy, 10", flared
15. nappy, 5", crimped
16. nappy, 5 ½", crimped
17. nappy, 7", crimped
18. nappy, 8", crimped
19. nappy, 9", crimped
20. nappy, 10", crimped
21. nappy, 5", shallow
22. nappy, 5 ½", shallow
23. nappy, 8", shallow
24. nappy, 9", shallow
25. nappy, 10", shallow
26. nappy, 11", shallow
27. plate, 5 ½"
28. plate, 6"
29. plate, 8", fruit
30. plate, 9", fruit
31. plate, 11", fruit
32. plate, 12", fruit
33. pickle tray, 6"
34. spoon tray, 6"
35. bon bon, number 1
36. bon bon, number 2
37. bon bon, number 3
38. celery, 13", oval
39. jelly, handled, 5"
40. jelly, handled, 5", three corner
41. jelly, handled, 5", crimped
42. jelly, high footed, 5"
43. jelly, high footed, 5 ½", crimped
44. jelly, high footed, 5 ½", shallow
45. bowl, high footed, 8"
46. bowl, high footed, 9"
47. bowl, high footed, 9", flared
48. bowl, high footed, 10", flared
49. bowl, high footed, 10", crimped
50. bowl, high footed, 11", crimped
51. bowl, high footed, 10", shallow
52. bowl, high footed, 11", shallow
53. punch bowl, 12"
54. punch bowl, 14", flared
55. punch bowl, 14", shallow
56. punch bowl, footed, 12"
57. punch bowl, footed, 14", flared
58. punch bowl, 14", footed, shallow
59. salver, 9"
60. salver, 10"
61. celery, tall
62. jug, ½ gallon, pressed handle
63. jug, ½ gallon, stuck handle
64. water bottle
65. tumbler
66. custard (punch cup), 3 ½ oz
67. custard (punch cup), 5 oz
68. toothpick
69. salt or pepper, No. 1
70. salt or pepper, No. 2
71. salt or pepper, No. 3 (same as #1, different top)
72. sugar sifter
73. oil, 2 oz, pressed or cut stopper
74. oil, 4 oz, pressed or cut stopper
75. oil, 6 oz, pressed or cut stopper
76. molasses can, 13 oz, OK top or N.T.
77. mustard and cover
78. pickle jar and cover

- 79. mug, handled
- 80. sugar, hotel
- 81. cream, hotel
- 82. candlestick, 9"
- 83. candelabrum, 2 light
- 84. candelabrum, 3 light
- 85. candelabrum, 4 light

- 19. sherbet, low footed, 5 oz, flared
- 20. sherbet, low footed, 6 oz, flared
- 21. sherbet, low footed, 4 oz, scalloped
- 22. sherbet, low footed, 5 oz, scalloped
- 23. sherbet, low footed, 6 oz, scalloped
- 24. egg cup, footed, 6 ½ oz
- 25. egg cup, footed, 6 ½ oz, flared

Stemware Items

- 1. goblet, 9 oz
- 2. goblet, 9 oz, flared
- 3. champagne, 6 ½ oz
- 4. champagne, 6 ½ oz, flared
- 5. claret, 5 oz
- 6. claret, 5 oz, flared
- 7. burgundy, 3 oz
- 8. burgundy, 3 oz, flared
- 9. wine, 2 oz
- 10. wine, 2 oz, flared
- 11. cordial, 1 ½ oz
- 12. cordial, 1 ½ oz, flared
- 13. oyster cocktail, 6 ½ oz
- 14. oyster cocktail, 6 ½ oz, flared
- 15. sherbet, low footed, 4 oz
- 16. sherbet, low footed, 5 oz
- 17. sherbet, low footed, 6 oz
- 18. sherbet, low footed, 4 oz, flared

References

- 1. Heisey Price List #100 (1902)
- 2. Heisey Price List #120 (1906)
- 3. Heisey Price List #142 (1908)
- 4. Heisey Catalog 50 (1905)
- 5. Heisey News, January, 1976, Pattern #1776
- 6. Heisey News, May 1976, #1776 Tumbler
- 7. Heisey News, May 1983, #1776 Little Things
- 8. Heisey News, July 1986, Chronology 1904-1909
- 9. Heisey News, June 1995, Chronology
- 10. Heisey News, October 1996, #1776 Molasses
- 11. Vogel Book I, pages 24-25c
- 12. Heisey Candlesticks, Candelabra, and Lamps, Felt & O'Grady, 317-318 ♦



1776 Kalonyal, Vogel Page 25







1776 Kalonyal, from Vogel I, Page 24A



1776 Kalonyal Table Set, from Vogel I, Page 24

## 2009 ALL HEISEY BENEFIT AUCTION

Dave Spahr

I hope you and yours had a very enjoyable holiday season and included among your New Year's resolutions a pledge to help your association in 2009 by sharing your resources, talents, and time. The very first thing you can do, if you haven't already, is check those curio cabinets and select and consign glass to HCA by January 15 for the 36<sup>th</sup> Annual All Heisey Benefit Auction which will be held at GMP Local #244 Union Hall in Newark, OH, on April 17-18, 2009.

As you know, the Benefit Auction is HCA's largest fund-raiser and 2009 will be another challenging year, financially, for the organization. As you read this article, you should have approximately two weeks to consign or donate your glass for the auction. We have included in this Newsletter a copy of the packing list and contract for your use. We would like you to fill out the list, as well as fill out two signed copies of the auction contract and place them both in the box of glass you bring in or ship to the Museum. FYI, the auction contract and packing list can be downloaded from the HCA website or copied from an earlier Newsletter.

As we have the last two years, we are going to only send out catalogs to those HCA members who placed absentee bids or were HCA members who purchased glass at one of our past auctions. The catalog will be on line on the HCA website on or about March 15 for anyone to use and download. In addition, for those who want a printed catalog, please contact the Museum and one will be sent to you. Sadly, many members do not participate in the auction, so we are trying to save money by reducing our printing and postage costs.

We will again let absentee bidders make their own arrangements to have their glass shipped. That worked very well the last two years. We will again provide a list of area vendors to pick up your glass, pack it, and send it to you. We simply do not have the volunteers, materials on hand, and staffing capability to do this task any longer. We will be giving instructions about this in future Newsletters, as well as in the catalog.

As you read this Newsletter, I will be looking for help to check in, inspect, catalog, and repack our auction glass. If you would like to help, please contact me. It is a great way to learn about the glass and meet some great volunteers.

If you have questions or concerns, please contact me at [masdgs@aol.com](mailto:masdgs@aol.com) or give me a call at 937-372-7166. Happy Heisey Hunting and I'll see you in April. ♥

## 2009 BENEFIT AUCTION CONTRACT



**Heisey Collectors of America, Inc.**  
169 West Church Street  
Newark, Ohio 43055  
Phone: 740.345.2932  
Fax: 740.345.9638  
[www.HeiseyMuseum.org](http://www.HeiseyMuseum.org)

This agreement is hereby entered into between (Please Print)

Owner / Consignor / Member \_\_\_\_\_

Address \_\_\_\_\_

City \_\_\_\_\_ State \_\_\_\_\_ Zip \_\_\_\_\_

Daytime Phone \_\_\_\_\_ Fax or E-mail \_\_\_\_\_

and Heisey Collectors of America, Inc., hereafter referred to as HCA, for glassware items consigned or donated for sale for the benefit of the National Heisey Glass Museum.

**Tentative Auction Dates: April 17-18, 2009**

**Auction Location: GMP Union Hall #244, 350 Hudson Ave, Newark, OH 43055**

### **Consignments:**

All items consigned for sale or donated are to be made by A. H. Heisey and Company or by other manufacturers using Heisey moulds. The owner/ consignor / member, hereafter referred to as the owner, agrees to accept all responsibility for providing merchantable title for all glass sold.

Each owner may consign a maximum of forty (40) lots to the auction. A list of glass being consigned or donated and prepared by the owner is attached as an integral part of this contract. There is no limit on the number of items in each lot, but HCA retains the right to increase/decrease size/make up of each lot. Each owner may donate an unlimited number of lots to HCA for sale at the auction. HCA, however, at its discretion, will consign donated items for auction, add donated items to the Museum collection, and/or sell donated items in the Museum Shop.

The HCA Auction Committee is authorized to reject any glass not deemed acceptable to HCA standards for this auction. These items may be returned to the consignor, if they desire, at their expense. Otherwise, these items become the property of HCA.

### **Commission:**

Owners of glassware to this sale will be charged on the following sliding scale of commission per lot: \$5.00-\$50.00= 40%; \$50.01-\$200.00= 30%; \$200.01-\$400.00= 20%; \$400.01-\$750.00= 15%; \$750.01 and over= 10%.

### **Settlement:**

Settlement for glass sold will be made in full not later than fifteen days after the completed auction from the HCA Auction escrow account. Said account is set up and operated consistent with ORC Section 4707.024. Collection of funds, bad checks, debts, and unpaid auction lots is the responsibility of HCA.

### **Responsibility:**

It is the responsibility of the owner to deliver the glassware to the National Heisey Glass Museum on or by January 15, 2009. HCA accepts responsibility for the glass after it is received at the Museum and until it is sold, except that any glass damaged in shipment to the Museum will be referred to the shipper and owner. All glass damaged or lost while in the

possession of HCA prior to sale will be valued by a qualified appraiser or appraisers and the owner will be paid on this basis, less commission.

**Bidding:**

The minimum opening bid on a lot will be at least \$5. The minimum incremental bid increase will be \$2.50. In the event no bid is received on a lot, that lot becomes a donation to HCA.

The owner and HCA both agree that absentee bids will be accepted by HCA. Per HCA policy, the minimum absentee bid on a lot will be \$15 with a minimum opening bid of \$5. Absentee bids are bids left by buyers prior to the auction and are executed in a competitive manner. We do not use the full bid amount as a starting bid. Bidding is initiated in the audience and then offered on behalf of the absentee bidder at the next increment continuously until bidding has stopped. HCA reserves the right to accept or reject any and all absentee bids. Example: Absentee bidder leaves a bid with a maximum amount of \$500. After item is sold through competitive bidding, the absentee bidder is successful for \$325. HCA is not responsible for misfiled bids that are not executed.

**Absolute Auction:**

All items are to be sold at an **absolute auction** and not at a reserve auction **except** HCA and the owner agree there will be a minimum opening amount (see Bidding above) on all lots without exception. Owners cannot bid or have others bid on their behalf on their own items.

*“Absolute Auction “ and “Reserve Auction” as defined by ORC. 4707.01:*

“Absolute Auction” means an auction of real or personal property to which all of the following apply:

- 1) The property is sold to the highest bidder without reserve.
- 2) The auction does not require a minimum bid.
- 3) The auction does not require competing bids of any type by the seller or an agent of the seller.
- 4) The seller of property cannot withdraw the property from auction after the auction is opened and there is a public solicitation or calling of bids.

“Reserve Auction” means an auction in which the seller or an agent of the seller reserves the right to establish a minimum bid, the right to reject or accept any or all bids, or the right to withdraw the real or personal property at any time prior to the completion of the auction by the auctioneer.

**General Auction Terms and Conditions:**

- 1) Payment: Cash, travelers check, certified check, or personal check (if approved by HCA). MasterCard and Visa cards are accepted. 5% buyers premium. Buyers premium deleted for cash or check payment. Cash only payment may be specified for individual bidders at HCA’s request.
- 2) HCA has endeavored to describe all items to the best of their ability, however this is not a warranty.
- 3) All items are sold as is and where is. The auctioneer has the right to make any verbal corrections at the time of sale and to provide additional information. Inspection is welcomed during preview and anytime before the item is sold.
- 4) In the case of a disputed bid the auctioneers have the authority to settle disputes to the best of their ability and their decision(s) is/are final.
- 5) The auctioneer has the right to reject any bid raise not in line with established bid increments.
- 6) All sales are final and all items must be paid for each day of sale.
- 7) Live telephone bidding may be available at HCA’s option and under special terms (contact HCA).
- 8) HCA is licensed as an auction firm by the Ohio Department of Agriculture and bonded in favor of the state.
- 9) HCA will provide auctioneers licensed by the Ohio Department of Agriculture and bonded in favor of the state.
- 10) Buyers assume full responsibility for items once they are sold unless otherwise specified by HCA.
- 11) Bidding on any item indicates acceptance of these terms.

OWNER SIGNATURE: \_\_\_\_\_ Date \_\_\_\_\_

HCA REPRESENTATIVE SIGNATURE: \_\_\_\_\_ Date \_\_\_\_\_



## 2009 HCA BENEFIT AUCTION CONSIGNOR PACKING LIST

Owner / Consignor / Member: \_\_\_\_\_



SHIP TO: HCA Auction, 169 W. Church St., Newark, OH 43055

DEADLINE: January 15, 2009

**Two signed copies of the contract must accompany your auction glass.**

Please put a "D" beside the lot number if the lot is to be donated to HCA.

Lot #	Qty	Pattern #/ Name	Description	Cut / Etch	Color	MARK	Damage
1							
2							
3							
4							
5							
6							
7							
8							
9							
10							
11							
12							
13							
14							
15							
16							
17							
18							
19							
20							
21							
22							
23							
24							
25							



# HEISEY GLASS MUSEUM PLAYING CARDS

We are now taking orders for the Heisey Glass Museum Playing Cards (Edition 3 - Green Deck) which we expect to receive early February. In addition, we will have for sale a limited number of uncut sheets (21" x 25") which will be suitable for framing. This deck features the Heisey animals and animal related items. The full color pictures are stunning and will make a good learning tool as well as a nice gift for all of your glass collecting friends. We will ship as soon as available. Orders for Card Cases (Cobalt) and the Red deck may also be placed on this form.

Name \_\_\_\_\_  
 Address \_\_\_\_\_  
 City \_\_\_\_\_ State \_\_\_\_\_ Zip \_\_\_\_\_  
 Phone and/or E-mail \_\_\_\_\_

I wish to order:	Total
_____ (number) Heisey Glass Museum Playing Cards (Green) @ \$10 each	_____
_____ (number) Heisey Glass Museum Playing Cards (Red) @ \$10 each	_____
Shipping per deck \$ 1.50 (can be picked up at Gift Shop)	_____
_____ (number) Uncut sheets of Heisey Playing Cards (Green) @ \$25 each	_____
_____ (number) Uncut sheets of Heisey Playing Cards (Red) @ \$25 each	_____
Shipping per uncut sheet @ \$5.00 each (can be picked up at Gift Shop)	_____
_____ (number) 1508 Card case in Cobalt @ \$24.95 each	_____
Shipping per card case @ \$6.00 each (can be picked up at Gift Shop)	_____
<b>Grand Total</b> (tax will be added when appropriate)	_____

Check # \_\_\_\_\_ Visa \_\_\_\_\_ Master Card \_\_\_\_\_  
 Card Number \_\_\_\_\_ Exp \_\_\_\_\_

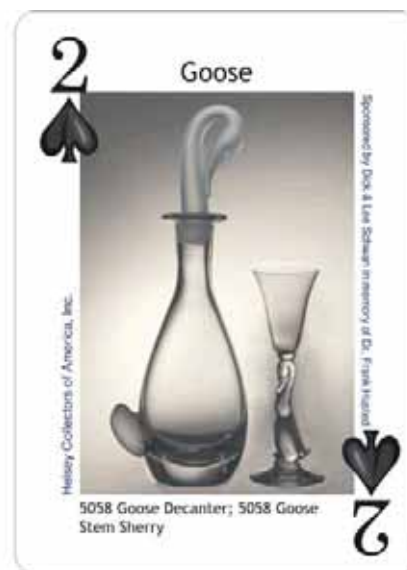
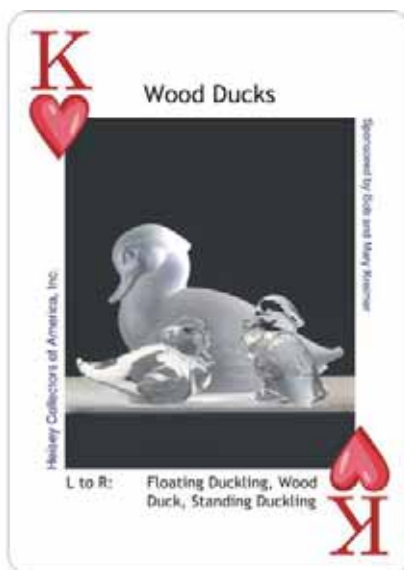
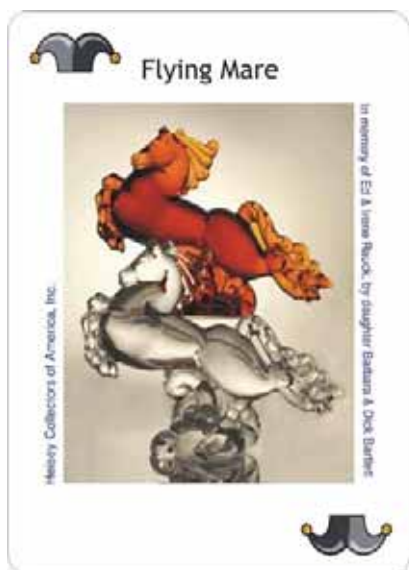

# APPROVED 2009 HCA BUDGET

	2006 ACTUAL	2007 ACTUAL	2008 BUDGET	10 MONTHS ACTUAL	% 10 MONTH vs TOT BUD	2 MONTHS EST	2008 EST	2009 EST BUDGET
<b>REVENUES</b>								
MEMBERSHIP	42,465	36885	38,100	29,546	77.55%	5,909	35,455	34,000
NEWSLETTER ADS	4,078	1974	3,075	804	26.15%	160	964	1,000
CASH DONATIONS	39,614	35339	37,700	18,929	50.21%	3,785	22,714	22,000
ACQUISITION DONATIONS	2,105	250	1,000	231	23.10%	45	276	1,000
SALES	38,030	63272	51,800	37,372	72.15%	7,474	44,846	44,800
SHIPPING CHARGES	3,358	2078	4,500	2,029	45.09%	406	2,435	3,200
ADMISSIONS	2,645	4429	4,300	3,038	70.65%	608	3,646	3,400
SPECIAL PROJ/ ROYALTIES	180	88	0	0	0.00%	0	0	0
INTEREST INCOME	239	521	420	578	137.62%	120	698	600
ARCHIVES	0	0	0	0	0.00%	0	0	0
AUCTION NET	15,368	15958	14,000	13,740	98.14%	0	13,740	13,800
SELECT AUCTION NET	3,688	5451	4,000	3,491	87.28%	0	3,491	3,500
CONVENTION NET	7,101	10525	7,875	5,059	64.24%	0	5,059	6,000
PERCY MOORE MEM NET	6,545	299	600	3,613	602.08%	0	3,613	600
ENDOW INC/RESERVE TRF.	36,700	44,500	70,390	68,600	97.46%	0	68,600	74,000
<b>TOTAL INCOME</b>	<b>202,116</b>	<b>221,569</b>	<b>237,760</b>	<b>187,030</b>	<b>78.66%</b>	<b>18,507</b>	<b>205,537</b>	<b>207,900</b>
<b>EXPENDITURES</b>								
ACCOUNTING EXPENSE	4,600	3250	4,000	4,015	100.38%	800	4,815	9,000
OFFICE SUPPLIES	7,082	5521	7,200	2,400	33.33%	480	2,880	3,000
REPAIRS / MAINTENANCE	9,044	17521	7,500	14,272	190.29%	2,854	17,126	9,000
GROUND MAINTENANCE	2,560	2547	3,200	4,297	134.28%	860	5,157	5,000
LEGAL FEES / RETAINERS	200	1218	1,750	2,272	129.83%	450	2,722	2,700
MISCELLANEOUS	6,148	3849	3,500	1,390	39.71%	280	1,670	1,295
AUCTION FIRM LICENSE	0	350	350	350	100.00%	0	350	350
UTILITIES	20,286	19614	21,300	15,695	73.69%	3,200	18,895	19,500
MUSEUM EXP./ EQUIP. RPL.	2,564	1384	21,120	235	1.11%	1,000	1,235	6,500
MEMBERSHIPS / SUBS	1,357	668	1,200	628	52.33%	500	1,128	1,200
INSURANCE	11,954	10000	12,600	5,694	45.19%	2,520	8,214	9,000
NEWSLETTER PRT & POST	14,198	12863	14,000	13,911	99.36%	2,782	16,693	17,200
SHIPPING	2,756	3122	3,600	2,257	62.69%	500	2,757	3,200
COST OF GOODS SOLD	8,495	16749	15,550	7,935	51.03%	1,587	9,522	10,000
BANK CHARGES	1,530	1904	2,100	1,470	70.00%	300	1,770	1,800
ACQUISITIONS	961	37	1,000	551	55.10%	449	1,000	1,000
MEETINGS / DINNERS	0	0	0	0	0.00%	0	0	0
ADVERTISING	3,397	3356	3,550	1,579	44.48%	320	1,899	2,400
COMPUTER MAINT	678	2787	8,500	5,804	68.28%	1,160	6,964	7,000
EMP / VOL RELATIONS	132	310	300	415	138.33%	100	515	500
SALARIES	63,425	67710	78,357	57,927	73.93%	11,585	69,512	72,108
EMP HEALTH INSURANCE	10,142	7365	8,780	9,187	104.64%	1,837	11,024	10,000
PAYROLL TAXES	5,422	4609	5,995	4,448	74.20%	1,000	5,448	5,515
WORKER'S COMP	1,987	2451	2,858	3,415	119.49%	700	4,115	2,632
<b>TOTAL EXPENDITURES</b>	<b>178,918</b>	<b>189,185</b>	<b>228,310</b>	<b>160,147</b>	<b>70.14%</b>	<b>35,265</b>	<b>195,412</b>	<b>199,900</b>
<b>LESS COST GOODS SOLD</b>	<b>8,495</b>	<b>16749</b>	<b>15,550</b>	<b>7,935</b>	<b>51.03%</b>	<b>1,587</b>	<b>9,522</b>	<b>10,000</b>
<b>PLUS INVENTORY PURCH</b>	<b>4,070</b>	<b>16349</b>	<b>25,000</b>	<b>14,271</b>	<b>57.08%</b>	<b>2,854</b>	<b>17,125</b>	<b>18,000</b>
<b>FUNDS REQUIRED</b>	<b>174,493</b>	<b>188,785</b>	<b>237,760</b>	<b>166,483</b>	<b>70.02%</b>	<b>36,532</b>	<b>203,015</b>	<b>207,900</b>



# HCA 2009 BUDGET

Sharon Orienter, Treasurer

The Board of Directors approved the 2009 HCA Operating Budget in the amount of \$207,900 at their meeting on December 12, 2008. The approved budget is shown on page 17 of this Newsletter. The final numbers for 2008 will appear in a subsequent issue.

An endowment income amount of \$74,000 is being used to balance the budget. This amount is the estimated 2008 earned income less fees from the endowment fund provided us by our fund administrator, Park National Bank. We have drawn down all available amounts of yearly earned income, less fees for five consecutive years to cover our operating costs.

This is my first year as HCA Treasurer and this budget is "bare bones." I am anticipating a decrease in membership, as we have been experiencing over the past three years and a decrease in cash donations. We received a most welcome and generous donation from the Percy & Vivian Moore Weekend in Jackson, Michigan, however, in 2009 the weekend will be in Newark. Past experience has shown that these weekends when held in Newark are far less financially successful. I am hoping that the exciting new plans for the Convention will yield no decrease in that income. Though our 2008 auction proceeds were lower than budgeted, I am anticipating that our new auction policy will enable us to maintain income in that area as well.

Our employees are very cognizant of our situation and are keeping costs down as much as possible. We have included a 3% increase for all employees in the 2009 budget. The awarding of the increase will be determined by annual review. We have carefully monitored expenses and have experienced the same cost increases you experience in your household. Utility bill increases; increased health insurance premiums, and property insurance raises affect us, also. The Board has ordered an audit and the estimated cost of that has been included in the accounting line. We do not anticipate any special maintenance needs this year as we had last year with the HVAC for the Archives. As in 2008, additional costs, if

necessary, will be taken from the Capital account. We hope to cap the Grounds Maintenance costs by employing a competitive bid process to acquire those services. We anticipate the computer maintenance costs to drop once the web site has been updated, but we will be including a monthly fee to keep it updated.

The budget is prepared by taking the first 10 months of costs and estimating the expenses for the last two months to arrive at the estimated 2008 operating expenses; then looking at the trends and costs over the past three years and developing the 2009 estimated revenues and expenditures. It is planned that any excess funds not spent will be placed in a reserve account for expenditures for needed projects in the future. Our Museum isn't getting any younger and needs continued maintenance.

The budget reflects a large reliance (35.5% of total revenue) on earned income and reserves to fund the organization and Museum operations. These economic times are unpredictable and though Park National Bank has assured us that we will likely not experience a reduction in that income, we have no such assurances about other areas of our revenue stream. We must continue to come up with innovative ways to increase revenues and reduce costs without reducing member services. Your Board of Directors and Staff are trying to do their part. We have received some great ideas in this past year and committees are working on turning these ideas into actions.

On behalf of the Board of Directors, I want to thank you for your interest in the finances of YOUR association, HCA, and your past support. We hope you will continue to support your organization with your time, talents, and financial resources in 2009 to keep our Museum a first class showplace and educational resource for members and public alike.

Should you have any questions concerning information in this article, the 2009 budget, or have any ideas you would like to share for raising funds, please feel free to contact me or any Board member. ♦

## 2009 HEISEY CONVENTION "ARTISTRY IN GLASS: THE HEISEY ETCHINGS"

Judy Rhoads & Mary Ann Spahr, Co-Chairs

As Ohio and other parts of the country enter the deep freeze and blustery weather of winter, I suggest we all close our eyes and fast-forward to June 2009.

Just imagine Newark, Ohio, in June...the trees and flowers are in bloom...the grass is turning into a thick green carpet...summer is just ahead.

With the help of many study clubs from across the country, the annual Heisey Convention is underway. We have all gathered to renew friendships acquired over the years, welcome first-time attendees, meet new Heisey collectors, and share treasures we have found since last year - especially the Heisey etchings!

We are learning how detailed etchings were accomplished, from design to application on the glass. We are learning about the beautiful Heisey etching patterns and their impact on the glass buying public of the time.

We are shopping, shopping, and shopping again the Premier Glass Show, as the dealers have emphasized the Convention theme by offering a wide selection of Heisey etchings. Many shoppers will add a wonderful piece of etched Heisey glass to their collections. Of course, the dealers will have your other favorite Heisey patterns, too.

Well, turn these imaginings into reality. Be sure that the first entry on your 2009 calendar is the HCA Convention on June 17-20, 2009! Walter has provided a list of Newark area hotels and lodging options for you on the next page. Make your reservations now and we will see you in Newark in June. ♦

## A WAY TO HELP HCA HCA Endowment Committee

Looking for a good way to help HCA and save money on your taxes? One of the byproducts of the recent government "bailout" program has given you just such an opportunity. If you are age 70 1/2 or older and have IRA or 401(k) retirement accounts, the rules say you must start withdrawing required minimum distributions (RMDs). These distributions are added to your taxable income each year.

However, the bailout plan provided an extension, which could benefit you and HCA. Through 2009, the donation of your RMD to HCA will prevent the donation from being counted as taxable income to you. The donation will satisfy your required distribution under IRA and 401(k) rules. This is possible because HCA is an accredited 501 (C) 3 tax - exempt organization.

Tax laws are quirky, and Congress can always enact changes. If you are in a position to help HCA through this provision, check first with your tax advisor for details to make sure you qualify for this benefit. If conditions fit your circumstances, contact HCA's Endowment Fund administrators at Park National Bank for instructions. Call 888-545-4762 toll free or 740-349-3702 and ask for either John Uible or Brad Zellar.

This could be a win-win for HCA and you! ♦

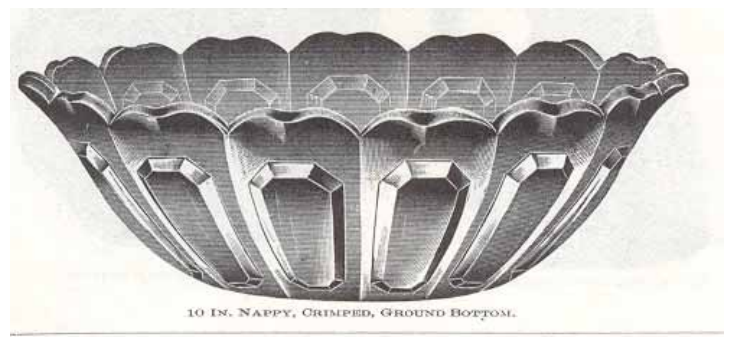

1776 Kalonyal 10" Crimped Nappy

# PLACES TO STAY IN THE NEWARK AREA

Walter Ludwig

As Mary Ann and Judy mention in their article on page 19, there are wonderful things planned for our 2009 Convention here in Newark. Convention is a time when we meet all of our old Heisey friends and hope to make some new ones. If you have never been to Convention, do make this the year you make it to Newark. A good time is had by all, including many chances to add some great pieces of Heisey to your collection.

It is not too soon to start planning to come to the 2009 Heisey Convention. Below is a list of accommodations compiled by the Licking County Convention and Visitors Bureau. Use the list also for your Benefit Auction reservations.

All of the locations on this list are within Licking County and are not too far from the activities. Those located in Newark, Heath, or Granville are the closest, however.

We are looking forward to seeing you. ♦

## HOTELS/INNS

### Best Western Lakewood Inn

122 Arrowhead Boulevard  
Hebron, Ohio 43025  
Phone: (740) 928-1800

### Buxton Inn

313 East Broadway  
Granville, Ohio 43023  
Phone: (740) 587-0001

### Cherry Valley Lodge home of CoCo Key Water Resort

2299 Cherry Valley Rd.  
Newark, Ohio 43055  
Phone: (800) 788-8008

### Courtyard by Marriott

500 Highland Blvd  
Newark, Ohio 43055  
Phone: (800) 321-2211

### Econo Lodge

1266 Hebron Road  
Heath, Ohio 43056  
Phone: (740) 522-6112

### Granville Inn

314 East Broadway  
Granville, Ohio 43023  
Phone: (888) 472-6855

### Hampton Inn

1008 Hebron Road  
Heath, Ohio 43056  
Phone: (800) 426-7866

### Holiday Inn Express Hotel

773 Hebron Road  
Heath, Ohio 43056  
Phone: (740) 522-0770

### Newark Budget Inn

176 W. Church Street  
Newark, Ohio 43055  
Phone: (740) 345-9721

### Quality Inn

733 Hebron Road  
Heath, Ohio 43056  
Phone: (800) 424-6423

### Red Roof Inn

10668 Lancaster Road SW  
Hebron, Ohio 43025  
Phone: (800) 733-7663

### Roadway Inn

4756 Keller's Road  
Hebron, Ohio 43025  
Phone: (740) 927-8011

### Shamrock Motel

8409 National Road SW  
Pataskala, Ohio 43062  
Phone: (740) 964-1920

### Star Lite

1342 Hebron Road  
Heath, Ohio 43056  
Phone: (740) 522-3207

### Super 8 - Buckeye Lake

I-70 & SR 79  
Buckeye Lake, Ohio 43008  
Phone: (740) 929-1015

### Super 8 - Heath

1177 Hebron Road  
Heath, Ohio 43056  
Phone: (740) 788-9144

### The Hebron Deluxe Inn

10772 Lancaster Road SW  
Hebron, Ohio 43025  
Phone: (740) 467-2311

### The Place Off The Square

50 North Second Street  
Newark, Ohio 43055  
Phone: (740) 322-6455

### University Inn

1225 West Church Street  
Newark, Ohio 43055  
Phone: (740) 344-2136

## BED & BREAKFASTS

### Cabin In The Woods Bed & Breakfast

6050 Blacksnake Road  
Utica, Ohio 43080  
Phone: (740) 892-2997

### Follet-Wright House B & B

403 East Broadway  
Granville, Ohio 43023  
Phone: (740) 587-0941

### Fraleigh House Bed and Breakfast

237 Clouse Lane  
Granville, Ohio 43023  
Phone: (800) 578-0611

### National Trail Schoolhouse Inn

10251 3rd Street  
Brownsville, Ohio 43721  
Phone: (740) 787-1808

### The George T. Jones House

221 East Elm Street  
Granville, Ohio 43023  
Phone: (740) 587-1122

### The Meadows

4409 Wesleyan Church Road  
Granville, Ohio 43023  
Phone: (740) 587-0439

### The Porch House

241 East Maple Street  
Granville, Ohio 43023  
Phone: (800) 587-1995

### WillowBrooke Bed n' Breakfast

4459 Morse Road  
Alexandria, Ohio 43001  
Phone: (740) 924-6161

## CABINS/CAMPING

### Buckeye Lake KOA

4460 Walnut Road  
Buckeye Lake, Ohio 43008  
Phone: (800) 562-0792

### Hidden Hill Campground

3246 Loper Road NE  
Newark, Ohio 43055  
Phone: (740) 763-2750

### Lazy River At Granville

2340 Dry Creek Road  
Granville, Ohio 43023  
Phone: (740) 366-4385

### The Little House at Bookmark Farms

8822 Morse Rd. S.W.  
Pataskala, Ohio 43062  
Phone: (740) 964-2601

### Shelter Valley Country Log Cabins

16232 Brushy Fork Road  
Newark, Ohio 43056  
Phone: (740) 763-2195



# INDEX FOR HEISEY NEWS

## VOLUME XXXVII 2008

Compiled by Joe Lokay

### Heisey Patterns

12 Single Row Slash and Panel	8, p 7
109, 110, 1234, 1236, 1238, 1240	
Sandwich Patterns	1, p 1
160 Locket on Chain	13, p 19
305 Punt and Diamond Point	4, p 7
315 Paneled Cane	7, p 8
325 Pillows	7, p 9
333 Waldorf Astoria Hotel Line	9, p 8
337 Plain Touraine	10, p 7
337 Plain Touraine, Optics	11, p 8
337 Plain Touraine, Decorations	11, p 10
343 and 343 ½ Sunburst	13, p 7
1245 Star and Zipper	12, p 9
1250 Groove and Slash	8, p 8
1255 Pineapple and Fan	12, p 10
1488 and 4085 Kohinoor	2, p 1
1540 Lariat Brochure (Two)	12, p 1
1567 Plantation Brochure (Two)	13, p 1
1590 Zodiac Advertisement	7, p 20
1637A Town and Country	7, p 18
3394 Gascony	4, p 1
4083 Stanhope	3, p 9
6009A Roundelay	7, p 18

### Individual Heisey and Related Items

503 Minuet Etch	3, p 1
517 Winchester Etch	3, p 12
518 Pan American Lei Etch	3, p 12
1164/1165 Finger Bowls	11, p 11
4192 Vase, Minuet Etch, Oct. 1940 (Ad)	9, p 25
Color Brochure	9, p 1
Crystal, Heisey, People's Choice (Ad)	12, p 5
Domesti-Cater Line	2, p 8
Epergnette Brochure	10, p 1
Flamingo Brochure	6, p 1
Gifts for Any Occasion Brochure	11, p 1
Ivy Cutting Advertisement	7, p 21
Knife Rests, Heisey	2, p 18
Moongleam Brochure	7, p 1
Moonglo Cutting Advertisement	7, p 21
Olympus Etch	11, p 18
Plunger Cut Trademark	3, p 15
Punch Bowl Sets in 1953	6, p 8
Rose Cutting Advertisement	7, p 21
Sahara Brochure	8, p 1

Stemware, Early 3, p 13

### Articles, General, Heisey Glass and Related Topics

Ad Campaign, Spring 1953, To Sell Heisey	2, p 20
Atlantic City Postcard	8, p 7
Confections Advertising, 1911 – 1914	9, p 23
Diamond Glassware, A Mystery	1, p 10
Etching Process (Part 2)	1, p 17
Fine Art, Heisey in	2, p 22
Frankly Rhyming, Airedale	1, p 25
Frankly Rhyming, Baccus	3, p 16
Frankly Rhyming, Ball Vases	4, p 12
Frankly Rhyming, Gayoso	2, p 25
Frankly Rhyming, a Letter	6, p 20
Index Heisey News 2007	1, p 8
Indexes, 30 Years of Heisey News	1, p 9
Kusak Cut Glass Works	4, p 19
Landmark Comes Down, Heisey Plant Stack	12, p 20
Marketing Heisey Glassware in the Early 1950s	4, p 17
Must Reading! (No, Not This Article)	4, p 9
Sears Catalog, Heisey in	7, p 11
Vernon Kilns Advertisement	4, p 11
Vernon Kilns, Heisey Tie-In Patterns	3, p 10
Workers, Former Heisey, Reunite	9, p 11

### Articles, General, HCA

Absentee Voting Procedures	2, p 14
Auction Holdback, 12/12/08	12, p 17
Auction Policy for Accepting Members Glass	10, p 11
Auction, Select 2008, Fourth Annual	6, p 21
Auction, Select 2008, Catalog & Instructions	10, p 17
Auction, Select 2008, Glassware List	4, p 21
Auction, Select 2008, News 10/18/08	10, p 16
Auction, Select 2008, Review	11, p 20
Auction, Select 2008, Results	12, p 22
Auction, Select 2008, Wrap-Up	13, p 23
Benefit Auction 2008, April 4 & 5	1, p 15
Benefit Auction 2008, A Preview	3, p 17
Benefit Auction 2008, Absentee Bid Form	3, p 20
Benefit Auction 2008, Catalog	4, p 1
Benefit Auction 2008, Contract	1, p 13
Benefit Auction 2008, Results	6, p 9
Benefit Auction 2008, Update	2, p 17; 3, p 19
Benefit Auction 2008, Volunteers	6, p 11
Benefit Auction 2008, Wrap-Up	6, p 11

Benefit Auction 2009

	11, p 12; 12, p 12; 13, p 12
Budget, HCA for 2008	1, p 11
Candidates for Board of Directors	6, p 18
Constitution Change, Proposed	6, p 18
Contributions, Museum, July – Dec. 2006	2, p 10
Contributions, Museum, Jan. – June 2007	9, p 19
Contributions, Museum, Jan. – June 2007, Addendum	10, p 10
Convention 2008, 37th Annual is Coming	1, p 20
Convention 2008, HCA Salutes Our Armed Forces	2, p 17
Convention 2008, 37th Annual	3, p 16; 4, p 12 6, p 12; 7, p 12
Convention 2008, Member's Display	8, p 22
Convention 2008, Pictures of Activities	8, p 18
Convention Silent Auction Glass Needed	3, p 18; 4, p 4
Convention 2009, June 17-20, 2009, Start Planning	13, p 23
Curator's Report	Monthly, p 4
Dealer Directory	Monthly, p 27
Deck 3, Heisey Playing Cards	7, p 17
Deck 3, Heisey Playing Cards, Sponsors	8, p 17
Donations, Convention Hospitality Room	8, p 17
Donations; Endowment, Operating, etc	9, p 20
Endowment Fund Giving	12, p 12
Endowment Fund Report, Dec. 31, 2007	2, p 14
Endowment Fund Report, March 31, 2008	6, p 16
Endowment Fund Report, June 30, 2008	9, p 17
Endowment Fund Report, Sept. 30, 2008	13, p 21
Flea Market Before Auction	11, p 3
Gift Shop Items	12, p 18
Gift Shop, New Items in the	8, p 12
Hotels/Motels/B&B in the Newark Area	1, p 21
Members, New	Monthly
Message from the President	Monthly, p 3
Moore Dinner Auction, Support Needed	8, p 14
Moore Weekend, Excitement Growing in Michigan	8, p 14; 9, p 14; 10, p 14
Moore Weekend Wrap-Up	8, p 21
Murder Mystery at the Heisey Museum	8, p 21
Museum Volunteers	Monthly, p 28
Playing Cards, Edition Two – Red Deck	9, p 16
Postal Form 3526	12, p 3
Study Club Directory	Monthly
Treasurer's Report, Year End 2007	2, p 15
Treasurer's Report, First Quarter 2008	6, p 16
Treasurer's Report, Second Quarter 2008	9, p 17
Treasurer's Report, Third Quarter 2008	13, p 21
Volunteer, Heisey Museum Wants You	2, p 15
Voting Members	2, p 12

## HOLIDAY HOLDBACK SILENT AUCTION RESULTS, DECEMBER 12, 2008

- |   |        |
|---|--------|
| 1. Set of three Colts, Black            | \$250  |
| 2. Sow + 4 sitting piglets, Yellow Mist | 100    |
| 3. Cygnet on bust-off, Lavender Ice     | 50     |
| 4. Tiger paperweight, Caramel Slag      | 80     |
| 5. Show Horse, Cobalt                   | 180    |
| 6. Asiatic Pheasant, Brown              | No Bid |
| 7. Fish bookend, Verde Green            | No Bid |
| 8. Madonna, Rosalene                    | No Bid |
| 9. Goose, wings down on bust-off, Ruby  | 75     |
| 10. Flying Mare, Cobalt                 | 450    |
| 11. Elephant, large, Ruby               | 200    |



## COOKIE DONATORS FOR OPEN HOUSE

Bryan Baker  
 Maxine Bartlett  
 Laureene & Jim Bollinger  
 Charlene Bowman  
 Linda Bishoff  
 Karen Clark  
 Flo & Joe Harner  
 Shelly Hoberg  
 Amy Jo & Chuck Jones  
 Walter Ludwig  
 Ginny Marsh  
 Mac Otten  
 Jinny Priest  
 Russ Reopell  
 Dick & Marilyn Smith  
 Kathy Smith  
 Mary Ann Spahr  
 Karen Taylo



1776 Kalonyal Shallow Nappy

# Study Club Directory

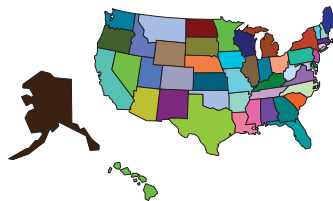

Interested in joining a study club? You will have the opportunity to meet fellow collectors and HCA members and learn more about your favorite glassware. If your club is not listed or you need to make corrections to your listing, please contact the Museum.

STUDY CLUB	MEET WHEN?	WHERE?	Email/Web Site	CONTACT
#4 Central Illinois Helsey Collectors Club	Four times a year	Members' homes or restaurants		Joyce Deany (815) 432-4310
#5 Bay State Helsey Collectors Club	2 <sup>nd</sup> Tuesday of each month except July, Aug., and Dec.	Whole Foods Community Rm, Bedford, MA	spescatore@houghton.com	Stephen Pescatore (978) 256-5418
#7 Dayton Area Helsey Collectors Club	3rd Tues. of the month Sept. to May, 6:30 p.m.	Huber Heights Library	LH937@aol.com	Joe Harner (937) 372-0852
#8 Helsey Heritage Society <i>NJ, Eastern PA and DE areas</i>	Four times per year	Members' homes	craigkratochvil@aol.com	Craig Kratochvil (973) 962-4004
#13 Helsey Club of California	4th Sunday every month, 12:30	Members' homes	herbet@sbcglobal.net www.heiseyclubca.org	Norval Heisey (818)-349-0945
#14 Northern Illinois Helsey Club	Four times a year	Members' homes	niheisey@comcast.net	Jeff Morrow (630) 833-4644
#15 Helsey Collectors Club of Michigan	Every six weeks, August to May	Members' homes	kilgoredesigns@att.net	Sue E. Kilgore (269)-345-3990
#16 Helsey Collectors of Texas	2nd Sat. of every odd month except May 1st Sat., 1 p.m.	Members' homes	sanddollars97@tx.rr.com www.heiseycollectorsoftexas.com	Greg Freeman (817)-545-5889
#19 Helsey Collectors of the Rochester Area	10 meetings per year: Sunday, 2:30 p.m.	Members' homes	seo2@aol.com	Sharon Orienter (585) 288-8076
#20 Buckeye Helsey Collectors Club <i>Newark, OH area</i>	September to May, 4th Monday	Members' homes or the Museum	Theflyingmaher@webtv.net	Michael Maher (740) 763-4256
#22 Northwest Helsey Collectors	First Saturday of the month	Members' homes	bahama50@hotmail.com	Deborah de Jong (425) 868-0457
#25 Helsey 76'ers <i>Columbus, OH area</i>	Once a month, September to May	Members' homes	ldburg48@aol.com	Colleen Burgess (614) 882-1884
#31 Nassau Long Island Helsey Club	Generally every other month	Members' homes		Babs Kent (516) 228-8274
#32 Dairyland Helsey Club	Once every two months	Members' homes		Ray K. Courtnege (414) 962-9747
#33 Golden Gate Helsey Collectors Club <i>Northern California</i>	Quarterly	Members' homes		Russ Nicholas (707) 762-2494
#36 Helsey Club of Southern MA	April, June, September, December			Maria Martell (508) 833-0633
#38 North Carolina Helsey Study Group	6 meetings per year: Jan.; March, May, July, Sept., Nov.	Replacements Ltd Greensboro, NC	Nchsg@yahoo.com www.northcarolinaheiseystudygroup.org	Karen Taylo (252) 637-9985
#39 Florida Helsey Collectors Club	4 times per year: January – February-March-April	Westchester Country Club Boyton Beach, FL	Shirley400@aol.com	Everett Dunbar (772)-337-1558
#42 Gulf Coast Helsey Club of Florida	Nov., Jan. and March; 2 <sup>nd</sup> Thursday 11:00 am	Members' homes		Jack Grenzenach (727)-391-5784
#43 Tri-State Helsey Study Club <i>OH, IN, MI</i>	1st Sat. every 3rd month	Members' homes	Maxwellm@cktech.biz	Mike Maxwell (260) 925-3484
#45 Hoosier Helsey Club	Four times a year	Warren Library, Indianapolis, IN		J. David Litsey, (317) 872-7800
#48 Dixieland Helsey Study Club	Odd number months, 2 <sup>nd</sup> Saturday night	Members' homes	www.dixielandheisey.org	Craig German (770) 967-8733
#49 Great Plains Helsey Club	March, May, July, September, and November	Members' homes	cameron_mg@mchsi.com www.greatplainsheiseyclub.org	Mary Cameron (515) 292-3743
#50 Northwoods Helsey Club of Minnesota	Four times a year	Members' homes	wheise@comcast.net	Bob Heise (952)-831-9335
#51 Helsey Club of Northeast Florida	Feb., May, Aug., and Nov. 2 <sup>nd</sup> Thursday	Avonlea Antique Mall, Jacksonville	Clasyglas2@aol.com	Barb Bartlett (904) 280-0450
#52 Northern Virginia Helsey Study Club	Monthly, Sept. – May	Members' homes	rreopell@verizon.net	Russ Reopell (703) 250-6117



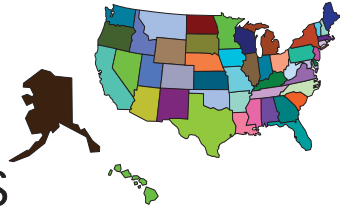

## CLUB NOTES

Heisey Collectors of Texas  
*Erma Hulslander*

Heisey Collectors of Texas gathered at Ann & Paul Keister's home in Plano, TX, with thirteen members present. For HCT, this was a good number and when we started talking Heisey you would think there were thirty of us there!! There was a short business meeting followed by our program.

Ann's program was on "Heisey Open Salts" during which she displayed almost every pattern that was made. Ann had all the colors in 1183 Revere salts (Cobalt, Flamingo, Moongleam, as well as crystal). The Revere color ones are very hard-to-find, since they are not marked. Another reason Heisey open salts are not too plentiful is that the last production by A. H. Heisey & Company was in 1937. An interesting note on the history of salts was that in centuries past it was not only a vessel to hold salt at the table, it was an indicator of social and economic status among and within families.

Our "Show & Tell" was outstanding, as always, and what a variety! Town & Country 1637A in "Dawn", 9 oz. tumblers and 6" plates; also in Dawn we saw 1632 Lodestar cocktails (beautiful); 1255 Pineapple and Fan toothpick in Emerald; a pair of Moongleam 129 Tricorn candlesticks; and a pair of 1510 Square on Round 2-light candlesticks; a dainty covered lemon dish in 1509 Queen Ann; a 3 lb. 465 Recessed Panel candy jar with ornate butterfly cutting; two footed salvers, one in 1220 Punt Band and the other 300 Peerless; a 9" 1469 Ridgeleigh ball base; a 4" rose bowl in 1205 Fancy Loop; a one-half gallon tankard in 393 Narrow Flute with beautiful designs of silver deposit; a 201 Harvey colonial tumbler in Amber; even a 4232 crystal favor vase; a cut 3389 Duquesne cordial; 4052 National 8 oz. old fashion with 980 Moonglo cutting; and a 1401 Empress 10" round salad bowl with a beautiful cutting!

Of course we ended our meeting munching on some great goodies as we talked Heisey. Thanks Ann and Paul for a wonderful afternoon!

Have a wonderful Christmas and New Year! We will see everyone in Plano, Texas, in January 2009, God Bless! ♦

Northwoods Heisey Club of Minnesota  
*Ann Moll*

Eight members were present at the autumn meeting of the Northwoods Heisey Club of Minnesota on November 8 at the home of Peggy Johnson and Lee English of St. Paul. They are the daughter and son-in-law of Odell and Virginia Johnson.

Our proceeds from this past Spring raffle and auction have been sent to HCA, in the amount of \$1068.62, to be divided between the Endowment Fund and operating expenses.

A display of Heisey will be showcased at the Edina Library and the Edina Senior Center sometime in the near future. We hope to secure a reservation during the first six months of 2009, as their planning is done on a six month basis. Heisey glass and books available at the library will be featured, plus information about the club.

The club set up an Information Table at the recent Pottery and Glass Show with a table inside the show area. Our club sign was above the display of Heisey, along with information about Heisey. Laminated bookmarks (made by Bev and Bob Heise), with details about the Club, were given to inquiring individuals. Those people will be contacted with the time and location of our next meeting.

The membership voted for and purchased out of NWHC funds, a 1229 Octagon ice bucket with elaborate cutting, to be given to the Museum in memory of Stephen Bergren, an original member of our Club, who recently died. This was presented to his widow, Eileen.

Show and Tell items were shared: 4092 Kenilworth footed soda with 497 Rosalie etching, 1951 Cabochon footed candy, and a bell made from a 5025 Tyrolean cordial with 507 Orchid etch.

## OPEN HOUSE – 2008

The program featured the 1503/5003 Crystolite pattern. Printed sheets of information about this Heisey pattern (copied from different articles in the Heisey News) were available, plus a few examples brought by members including two sizes of plates, a divided relish, blown and pressed tumblers, 5" breakfast preserve (with cover), small powder box with cover, a square candle block, and a 7" covered candied dish.

At the close of the meeting, apple cider (in Heisey tumblers), coffee, and blueberry coffeecake were served. Our hosts shared their collection of Fiesta, their collection of Orchid etch, and provided a tour of their restored over one hundred year home. ♦

Northern Virginia Heisey Study Club  
*Russ Reopell*

The Northern Virginia Heisey Study Club gathered on December 7 to celebrate the Holidays and kindred spirits of Heisey collecting. Instead of a business meeting followed by a program, the group of 16 enjoyed "heavy" hors d'oeuvres that were brought by the members present. Bryan Baker and President Suzanne Parker set a festive table with many Heisey colonial serving pieces. While Bryan served Egnog with "Spirits" from a 393 Narrow Flute half gallon jug, folks loaded their plates with the wide assortment of goodies prepared by our members. Let's just say that this Virginia crowd really knows how to put on a feast. The meal was topped off with a delicious three-layer cake with caramel frosting prepared by Kelly Shirley – and, of course, served on a 1567 Plantation cake salver. There was lots of great discussion, merriment, and laughter all around; a wonderful afternoon to share with Heisey friends, and the telling of tales of great Heisey finds. Happy New Year to All!! ♦

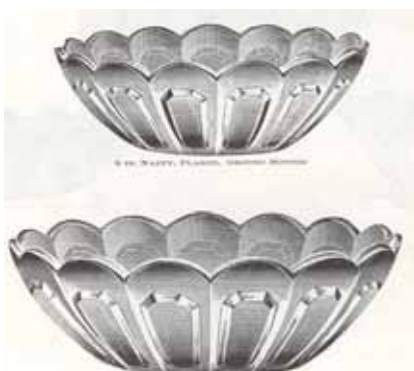

1776 Kalonyal Flared Nappies



Santa Was There



Dayton Certainly Helped



The Craft Project Was Popular



And So Were the Goodies



**Advertising Guidelines:**

Advertising: Ads may be mailed to: HCA Advertising, 169 W. Church St., Newark, OH 43055; faxed to (740) 345-9638; or e-mailed to [curator@HeiseyMuseum.org](mailto:curator@HeiseyMuseum.org). Whenever possible, please e-mail your ad. Include your MasterCard or VISA number and expiration date for billing purposes, or send a check. All ads must be prepaid. When mailed or faxed, ads should be typed or printed on white paper with dark ink. Please double space. Ads that are entered in a vertical column format may contain a maximum of 65 characters per line, including spaces & punctuation.

Classified: 20 cents per word (members), 30 cents per word (non-members), \$1.50 min., 1/8 page limit. Personal ads 1/8 page limit. Abbreviations & initials count as words.

Display Ads:	member	nonmember
1/8 page (12 lines)	\$ 20	\$ 30
1/4 page (25 lines)	\$ 40	\$ 60
1/2 page (60 lines, horizontal or vertical)	\$ 80	\$ 120
Full page (120 lines)	\$160	\$240

A charge of \$1.60 will be added for each additional line.

1/2 page: 4 1/2" high by 7 1/2" wide or 9" high by 3 1/2" wide

Full page: 9" high by 7 1/2" wide

Ad copy must be received by the first of the month prior to publication. Reproductions (i.e., Heisey by Imperial) must be indicated. Heisey News accepts no further liability. In the event of a typographical error, the incorrect portion of the ad will be run in the following issue, but HEISEY NEWS assumes no further liability.

Camera-ready ads may be resized because of space concerns.

Ad copy must be received by the first of the month prior to publication. Reproductions (i.e., Heisey by Imperial) must be indicated. Heisey News accepts no further liability. In the event of a typographical error, the incorrect portion of the ad will be run in the following issue, but HEISEY NEWS assumes no further liability. ♦

**Classified Ads**

**Coming to Chicagoland,  
The Largest-36th Annual Elegant  
& Depression Glass Show,  
See all the Colors & Patterns,  
Own a Piece of American History!**

March  
28th & 29th  
2009

Sponsored by  
The 20-30-40 Glass Society of Illinois  
P.O. Box 856, La Grange Illinois 60525  
Website: [WWW.20-30-40society.org](http://WWW.20-30-40society.org)

<b>March 28th &amp; 29th 2009</b>	
Saturday 9 am - 5 pm	Sunday 10 am - 4 pm
<b>Concord Plaza</b>	<b>Midwest Conference Center</b>
<b>401 West Lake St.</b>	<b>Northlake, Illinois 60164</b>
Admission \$8.00 Per Person	
\$7.00 with this card - Limit 2	
Free Parking with shuttle bus to front door	
Crystal Repair; Glass Identification; Reference Library; Door Prizes.	
All attendees will be processed as associate members for this event.	

♦ **Reciprocal Ad**

# Find the Best of Heisey Glass...

...with popular patterns like Orchid, Heisey Rose, Minuet, and hundreds more. We also carry other fine crystal and depression glass from Cambridge, Fostoria, Imperial, Duncan & Miller, and more. The world's largest supplier of old and new china, crystal, flatware and collectibles, Replacements, Ltd. carries over 11 million pieces in inventory in over 250,000 patterns.

If you're looking to add to your collection, or if you're looking to sell — call us toll-free. We're always looking for more.



**REPLACEMENTS, LTD.**  
China, Crystal & Silver • Old & New  
Dept. HS, PO Box 26029, Greensboro, NC 27420  
[www.replacements.com](http://www.replacements.com)

1-800-REPLACE (1-800-737-5223)

♦ **Paid Ad**



Designs of the Past



That Dazzle Today!



South Florida Depression Glass Club  
American Glass, Pottery, Dinnerware Show and Sale

February 7 & 8, 2009  
Sat. 10am-5pm & Sun. 10am-4pm  
War Memorial Auditorium • 800 NE 8th St • Ft. Lauderdale, FL

♦ **Paid Ad**



# Dealer Directory

Maximum 6 lines/12 months/\$35 MEMBERS ONLY

Contact the Editor to place your ad!



<p><b>KIM &amp; PAM CARLISLE</b> SHOWS &amp; MAILORDERS ONLY 28220 Lamong Rd. Dept. H Sheridan, IN 46069 Glass Cleaning Services Available (317) 758- 5767 <a href="mailto:kcarlisl@worldnet.att.net">kcarlisl@worldnet.att.net</a></p>	<p><b>SHIRLEY EUGENIA DUNBAR</b> Heisey a Specialty—Mail Order, Shows, Appraisals EMAIL: <a href="mailto:shirley400@aol.com">shirley400@aol.com</a> PO Box 8344, Port St. Lucie, FL 34952 Oct-May (772) 337-1558 PO Box 222, Naples, ME 04055 May-Oct (207) 647-5652</p>	<p><b>SUM OF LIFE</b> Elaine Husted: 610-469-1243 147 Barton Dr., Spring City, PA 19475 Traveling through eastern PA Call, stop in, be a buyer or a browser!! E-mail: <a href="mailto:1classycat@comcast.net">1classycat@comcast.net</a></p>
<p><b>ALL HEISEY AUCTION</b> Consignments Welcome Apple Tree Auction Center 1616 W. Church, Newark, OH 43055 (740) 344-4282</p>	<p><b>MOUNDBUILDERS SECOND GENERATION</b> Barbara and Richard Bartlett Heisey Exclusively! 1-904-280-0450 PO Box 1931, Ponte Vedra Beach, FL 32082 Toll Free 1-888-434-7397(HEISEYS) EMAIL: <a href="mailto:CLASYGLAS2@AOL.COM">CLASYGLAS2@AOL.COM</a></p>	<p><b>EAGLES REST ANTIQUES</b> <i>Buying Heisey, China &amp; Pottery</i> Carl and Mary Evans 62 Fieldpoint Rd., Heath, OH 43056 (740) 522-2035</p>
<p><b>PAULA &amp; JEFF MORROW</b>  Elegant Glassware and American Dinnerware 126 Clinton Avenue Elmhurst, IL 60126 (630) 833-4644 <a href="mailto:mor-fab@comcast.net">mor-fab@comcast.net</a></p>	<p><b>H &amp; R DIAMOND H</b>  Helen &amp; Bob Rarey 1450 White Ash Dr. Columbus, OH 43204 (614) 279-0390 after 5:30</p>	<p><b>The American Bell Association</b>  P.O. Box 19443 Indianapolis, IN 46219-0443 <a href="http://www.americanbell.org">www.americanbell.org</a></p>
<p><b>REALMS IN GLASS</b>  Roy Eggert Heisey Custom Stained Glass 12009 Fingerboard Rd, Monrovia, MD 21770 301-865-5196 <a href="mailto:roy54@hughes.net">roy54@hughes.net</a></p>	<p><b>PIECE BY PIECE ANTIQUES</b> Buy &amp; Sell Specializing in Heisey Glassware Bryan K. Baker Fairfax Station, VA 22039 Newark, OH 43055 (703) 250-6117 <a href="mailto:piecebypiece@verizon.net">piecebypiece@verizon.net</a></p>	<p><b>PATTON HOUSE ANTIQUES</b> Specializing in Glass*Heisey*Cambridge*Fostoria*Duncan* Factory Antique Mall, Verona, VA off I-81 Exit 227 Antiquers Mall, Booth 81, Rt. 29 N., Charlottesville, VA The Daniels, Box 547, Louisa, VA 23093 (540) 967-1181</p>
<p><b>C&amp;J ANTIQUES</b> Cole &amp; Jean Miesner Box 45, 72 Whig St. Newark Valley, NY 13811 (607) 642-9905</p>	<p><b>SIBYLS OF WILMINGTON</b> Sibyl &amp; Ned Lavengood at Castle Corner Antiques 555 Castle St. Wilmington, NC (910) 264-9597 or <a href="mailto:Sibylsantiques@bellsouth.net">Sibylsantiques@bellsouth.net</a></p>	<p><b>FRAN'S FANCY FINDS</b> Fran &amp; Jack Grenzebach 10534 Valencia Rd., Seminole, FL 33772-7511 (727) 391-5184 SHOWS MAIL ORDERS</p>
<p><b>CRYSTAL LADY</b> Bill, Joann &amp; Marcie Hagerty Specializing in elegant depression glassware 1817 Vinton St., Omaha, NE 68108 Shop (402) 341-0643 or Home (402) 391-6730 Email: <a href="mailto:ejhagerty@aol.com">ejhagerty@aol.com</a> website:<a href="http://www.crystalladyantiques.com">www.crystalladyantiques.com</a></p>	<p><b>PASTICHE ANTIQUES</b> at Preston's Antique Gaslight Village US 12, Allen, MI 49227 Elegant Glass and Other Fine Antiques <a href="mailto:pasticheantiques@gmail.com">pasticheantiques@gmail.com</a></p>	<p><b>WILLEY'S ANTIQUES &amp; MUSEUM</b> Specializing in Heisey 11110 Cannon Rd., Frazeesburg, OH 43822 16 miles east of Newark, OH (740) 828-2557</p>
<p><b>CHARLES &amp; MILDRED FISHER</b> Heisey animals and Heisey By Imperial animals 1607 Dayton Rd, Newark, OH 43055 <a href="mailto:Cfisher08@roadrunner.com">Cfisher08@roadrunner.com</a> (740) 281-3104</p>	<p><b>MARSH'S ANTIQUES</b> Dick and Virginia Marsh 4532 Newton Road Newark, OH 43055 <a href="mailto:swamp@alink.com">swamp@alink.com</a> (740) 366-5608</p>	<p><b>MOONGLEAM ANTIQUES</b> Heisey Glassware &amp; American Art Pottery John Woytowicz and Peter Rivard 70 Pleasant St., Gardiner, ME 04345 (207) 582-9048 E-mail: <a href="mailto:jmwpwr@aol.com">jmwpwr@aol.com</a></p>
<p><b>ROBERT M. LOCH</b> Voting Member HCA and NWHC Pacific Interstate Glassware Co. PO BOX 469 Custer, WA 98240 360-366-3166</p>	<p><b>CRESTONE MANOR UNIQUES</b>  Harold &amp; Loleta Hammtree 3317 Crestone Circle, Chattanooga, TN 37411 423-629-1274 <a href="mailto:hammonl@bellsouth.net">hammonl@bellsouth.net</a> Heisey Only</p>	<p><b>APPLE VALLEY COLLECTIBLES</b> Richard &amp; Marilyn Garnett – Owners Shows/ Mail Order (845) 691-6308 Email: <a href="mailto:diamondH95@aol.com">diamondH95@aol.com</a></p>
<p><b>DOWNSTAIRS AT FELTON ANTIQUES</b>  100B Felton St, Waltham, MA 02453 781-894-2223 <a href="mailto:info@feltonstreetantiques.com">info@feltonstreetantiques.com</a> GLASSWARE, POTTERY, EPHEMERA, STERLING, FURNITURE FROM EVERY DECADE!</p>	<p><b>WM GLASS</b>  Bill &amp; Mary Barker 400 Nantucket Ave., Pickerington, OH 43147 (740) 927-0918 <a href="mailto:mcbarker@embarqmail.com">mcbarker@embarqmail.com</a> Heisey Only</p>	<p><b>WATERSEdge ANTIQUES</b> Norene &amp; Don Walzer Shows &amp; Mail Order 25089 Riverwalk Drive Leesburg, FL 34748 (352) 314-8975 <a href="mailto:dnnwalzer@embarqmail.com">dnnwalzer@embarqmail.com</a></p>
<p><b>JERRYS' ANTIQUES</b> Shows Only Glassware and Other Fine Collectables PO Box 4485, Davenport, IA 52808 563-340-1871 <a href="mailto:jerrysantiques@mchsi.com">jerrysantiques@mchsi.com</a></p>	<p><b>ONCE AND FUTURE ANTIQUES</b>  Susan &amp; Stephen Pescatore 9 Donna Rd. Chelmsford, MA 01824 (978) 256-5418 Heisey and Elegant Glass</p>	<p><b>BOB &amp; MARY KREIMER</b> Specializing in Heisey Glass 7044 SW 116<sup>th</sup> Loop, Ocala, FL 34476 (352) 873-8306 email: <a href="mailto:rkreimer@earthlink.net">rkreimer@earthlink.net</a>. Shows and Mail Orders Only</p>
<p><b>J &amp; L TREASURES</b> Specializing in Heisey, Cambridge, Fostoria, Tiffin, Morgantown, etc Linda Kilburn, PO Box 1257, Burlington, CT 860-673-4088 <a href="mailto:jltreasures@comcast.net">jltreasures@comcast.net</a></p>	<p><b>Charlene Bowman</b> Shows Only Heisey – Cambridge – Fostoria - Morgantown P.O Box 287, Clarksville, OH 45113 937-289-2114 <a href="mailto:twoclbs@aol.com">twoclbs@aol.com</a></p>	<p><b>YELLOW BRICK ROAD ANTIQUES</b> Jean Will Leavenworth, KS 66048 (913) 682-4831 Specializing in Heisey and Elegant Glassware Shows and Estate Sales</p>

## When Renewing Your Membership

Help ensure the future of your Museum. When you renew your membership at one of the levels below, any amount beyond the regular Associate dues goes into the Endowment Fund.

<i>Individual Contributing, one person in household</i>	<i>\$50</i>
<i>Joint Contributing, two people in one household</i>	<i>\$60</i>
<i>Family Contributing, parents and children under 18</i>	<i>\$75</i>
<i>Patron</i>	<i>\$125</i>
<i>Sponsor</i>	<i>\$250</i>
<i>Benefactor</i>	<i>\$500</i>

Visit The  
National  
Heisey  
Glass  
Museum



Come at your leisure to enjoy more than 4,800 pieces of glassware produced by A.H. Heisey and Company from 1896-1957. Hundreds of patterns are featured in all production colors. Rare and experimental items are included as well.

Facilities are air-conditioned and handicapped accessible. Hours are 10:00 a.m. to 4:00 p.m. Tuesday through Saturday, 1:00 to 4:00 p.m. Sunday (except Jan. and Feb.). Members are admitted free, regular admission is \$4. Office hours are 8:00 a.m. to 4:30 p.m. weekdays.

**Membership Renewal Notice:** Check the date above your name and address on the mailing label. This is your expiration date. If it reads 1-10-09 make sure your dues are paid soon in order to receive next month's issue of *Heisey News*.

Contact the HCA Administrative Office at (740) 345-2932 for more information. The Endowment Committee wishes to thank those who have become Endowment Members and all of the individuals and study clubs that have so generously supported the HCA Endowment Fund. All members who have supported the fund are recognized each year in the February issue of the Newsletter. Your support will make the Museum self-sustaining in the years to come. Thank You all! ♦

### Shipping & Handling Fees for Outside US

Additional shipping charges are required for members living outside the U.S. Current rates are Canada \$22; for other countries contact the Museum. Rates are subject to change at any time due to rate changes made by the US Postal Service. To verify current rates, call (740) 345-2932 or E-mail [business@HeiseyMuseum.org](mailto:business@HeiseyMuseum.org)

## Museum Volunteers for November 2008

Jim & Karen Clark  
Chuck & Amy Jo Jones  
Frank Kuhlmann  
Dick Marsh  
Phyllis McClain  
Don & Pat Moore  
Sharon Orienter  
Jinny Priest  
Bob Rarey  
Dick Ritter  
Dick & Marilyn Smith  
Tanner Temnick



### Periodical Postage

Paid at the Post Office  
In Newark, OH 43055  
Publication # 00986  
POSTMASTER SEND FORM 3579 TO:  
HCA  
169 W. Church St.  
Newark, OH 43055

To: \_\_\_\_\_