

HEISEY NEWS

The Official Publication of Heisey Collectors of America, Inc.

Volume XXXVIII No. 6

June 2009

ISSN 0731-8014

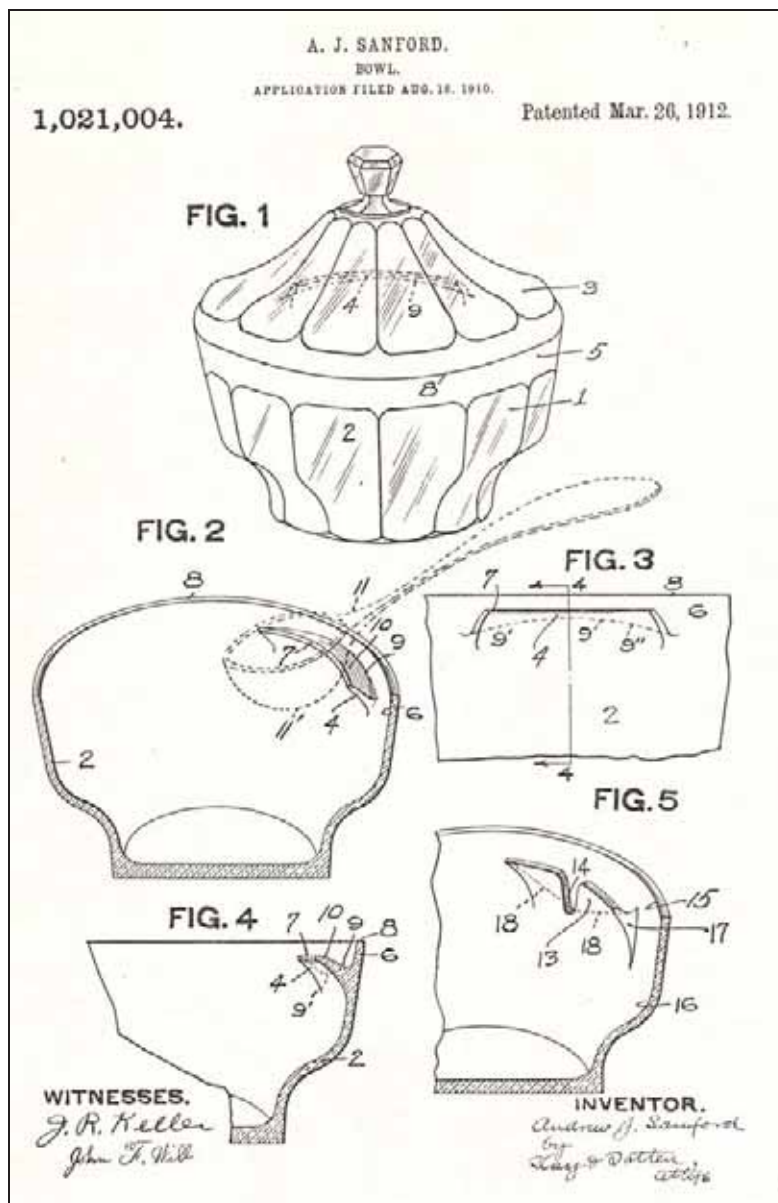

Patent 1,021,004

Read Part Four of the Story of A. H. Heisey Utility Patents on Page 5

HEISEY NEWS

Heisey Collectors of America, Inc.
169 West Church Street
Newark, Ohio 43055
Phone 740-345-2932 Fax 740-345-9638
Web Site: www.heiseyMuseum.org
All Rights Reserved 2009
ISSN 0731-8014

Staff and Phone Extensions

Curator, Walter Ludwig, curator@heiseyMuseum.org, Ext. 4
Clerks, Justin Church, Amanda McDonald
membership@heiseyMuseum.org, Ext. 1
Gift Shop, Ext. 5

HCA Board of Directors:

President, Bryan Baker - Fairfax Station, VA, 703-250-6117 –
hcapresident@heiseyMuseum.org
Vice-President, Charlie Wade – Newark, OH 740-587-2002
Secretary, Amy Jo Jones - Beavercreek, OH, 937-426-1567
Treasurer, Sharon Orienter – Rochester, NY, 585-288-8076
Member-at-Large, Dave Spahr - Xenia, OH, 937-372-7166

Sid Edwards – Tallassee, AL, 334-283-4663
Tom Files – Kansas City, MO, 816-468-7087
Ron Keener – Heath, OH, 740-323-3747
Sue Kilgore – Kalamazoo, MI, 269-345-3990
Robert Loch – Custer, WA, 360-366-3166
Jack Metcalf – Utica, OH, 740-892-2664
Karen Taylo – New Bern, NC, 252-637-9985

HEISEY NEWS is published and printed monthly (twice in March), by Heisey Collectors of America, Inc. (HCA). Periodical postage paid at Newark. Subscription is limited to HCA members. First class mailing is available for an extra \$20.00, due with payment of membership. If you are having difficulty receiving your Newsletter, please contact the HCA Administrative Office Monday through Friday 8:30 a.m. - 4:30 p.m.

The opinions expressed in articles in HEISEY NEWS are those of the authors and not necessarily those of the organization. The Editorial Staff reserves the right to edit, with or without the consent of the author or to refuse any material submitted for publication.

Back Issues

Back Issues available from files are \$3.00 per issue plus shipping and handling

Advertising

Ads may be mailed to: HCA Advertising, 169 W. Church St., Newark, OH 43055; faxed to (740) 345-9638; or e-mailed to curator@HeiseyMuseum.org. Whenever possible, please e-mail your ad. Always include your MasterCard or Visa number and expiration date. When mailed or faxed, ads should be typed or printed on white paper with dark ink. Camera ready ads are accepted, but must follow line specifications outlined at the beginning of the advertising section. Ads containing reproductions will not knowingly be accepted unless clearly stated (e.g. Heisey by Imperial, etc.). HEISEY NEWS accepts no further liability. In the event of a typographical error, the incorrect portion of the ad will be run in the following issue, but HEISEY NEWS assumes no further liability. See advertising section for rates and deadlines.

Museum

Heisey Collectors of America, Inc., a non-profit corporation (tax-exempt status), owns and operates The National Heisey Glass Museum in Veterans Park, 6th and Church Streets, Newark, Ohio. Open year round, Tuesday through Saturday 10:00 a.m. – 4:00 p.m., Sunday 1:00 – 4:00 p.m. (except Jan. and Feb.), closed holidays. Other hours by appointment. Members admitted free.

Identification

HCA will attempt to identify unknown glass items. Send a color photograph, measurements, and a self-addressed, stamped envelope to the attention of the Curator. Other arrangements should be made in advance with the Museum staff. Please keep in mind that the Museum cannot appraise items. Identification is free to members, non-members \$5.00 per item.

Membership

To join Heisey Collectors of America or to renew your membership, contact the HCA Administrative Office Monday through Friday 8:00 a.m. - 4:30 p.m. Eastern Time. Associate dues are \$30.00 plus \$5.00 for each additional household member. Voting members pay an additional one-time fee of \$25.00. Please consider supporting the Endowment Fund by joining at one of the levels listed on the back page.

Museum Gift Shop

There is always someone in the Gift Shop during the Museum's hours of operation to help answer questions or take orders. When ordering by phone, please have a credit card ready. When ordering by mail, please be sure to include appropriate charges such as shipping and sales tax. Please note that the HCA member discount does not apply to original Heisey or special project items.

Shipping and Receiving

Delivery is made much easier when we have a complete street address, not a PO Box. We prefer to use UPS. If you have not received a package, please call the Administrative Office to confirm it was sent. We will assist you in tracing it. If your package arrives damaged, please contact your local UPS representative. We insure everything.

Donations and Loans to the Museum

If you would like to make a donation to the Museum or have questions regarding items on loan, contact the Curator. HCA reserves the right to accept or refuse items based on current holdings.

HEISEY CALENDAR OF EVENTS

2009

Convention Registration Deadline	June 4
Absentee Ballot Deadline to Have at Museum	June 18
Heisey National Convention and Elegant Glass Show Newark, OH	June 17-20
Percy and Vivian Moore Memorial Weekend	October 2-3
2009 Fifth Heisey Select Auction	October 3
December Holiday Open House	December 5

Table of Contents

Utility Patents Associated with A.H. Heisey & Company (Part 4), Walter Ludwig	FC & 5-8
Heisey Calendar of Events	2
Message from the President, Bryan Baker	3
Curator's Report, Walter Ludwig	3-4
HCA Welcomes New Members for April 2009	4
429 Plain Panel Recessed, Joe Lokay	8-11
462 & 462 ½ Nail, 449 & 450 Nail, Joe Lokay	12-13
371 Scalloped Top Curved	13-14
445, 1127, and 1129 Fine Tooth	14-15
Heisey Glass Museum Playing Cards, Order Form (Green Deck)	16
2009 HCA Convention News Co-chairs, Judy Rhoads and Mary Ann Spahr	17
2009 Convention Schedule of Events	18
HCA Convention 2009 Registration Form	19
Etching Ads, Walter Ludwig	20-21
Study Club Directory	22
Club Notes	23-25
Advertising Guidelines	25
Classified Ads	25-26
Dealer Directory	27
Museum Volunteers for April 2009	BC

MESSAGE FROM THE PRESIDENT

Bryan Baker

It is Convention time in Newark! Get those last-minute reservations made and join all your Heisey friends for what is sure to be a great time. I've been doing my Convention weather dance in hopes that we once again have fair skies and comfortable temperatures. Not to worry, most of our events will be inside in nice air conditioned facilities. So no excuse – we hope to see you there.

For those that do make the trip, please make sure you stop by the Museum to see our new Endowment Plaques. In my previous article, I had mentioned our current plaque has become full, forcing us to obtain additional boards. This is good! As you know, our Endowment Fund is vital for our future. We take pride in recognizing major contributors to this fund via specific giving levels (Bronze, Silver, Gold, and Diamond). Perhaps now is the time to add your name or the name of a loved one to this special place in our Museum. Contact a Board member or Museum staff for more information. And as always – EVERY donation to this fund is deeply appreciated.

We continue to monitor our operating budget, and I must say that in spite of our current economic downturn, we remain on target for the year. This is not without the hard work of our staff, volunteers, and board members; in particular our Treasurer Sharon Orienter. We are doing our best to monitor operating costs, and where possible reduce those costs. 2010 will continue to be a challenge for HCA and the Museum. We keep looking for that one huge project that will generate much needed revenues. However, the reality is that we will need many diverse projects along the way. Your ideas are most welcome.

Being a non-profit, we rely heavily on our membership for financial support. Membership renewals are a significant part of our operating

revenues. As they say, membership has its privileges – a top notch newsletter, access to a first class Museum, and we hope soon to have the new website up and running that will have a “members only section.” This portion of the website will be available in the near future. It goes without saying that your continued support is vital.

As reported last month, we had a VERY successful Benefit Auction. To have a good auction, it goes to say you need good glass. Our members once again provided that. Our next big auction is the annual Select Auction scheduled for Saturday, October 3. Here is another great opportunity for HCA to generate some much needed revenue.

Thank you for all you do for HCA and our Museum. See you at Convention!

Until next time,

Bryan Baker ♦

CURATOR'S REPORT

Walter Ludwig

A year has now passed since we gathered here in Newark for the last Heisey Convention. That was a great one, but the hard work that co-chairs Mary Ann Spahr and Judy Rhoads have put into preparing this year's events should make this one of the best Conventions ever. They have come up with so many new ideas that even those that have been here many times are sure to find some things that they never expected to find here in Newark. We have more dealers in the show than we had last year; we have more events packed into the four Convention days than we have had before; we have more fun and enjoyment planned for everybody. It is not too late to make your reservation. Give us a call and we will sign you up. Of course, you can still come to Convention even if you do not register – you will miss some of the special events, however. The show will be open Thursday from 1:00 to 7:00 (special longer hours so those that are working can still get to

the show), as well as from 12:00 to 5:00 on Friday and Saturday. On Saturday, admission is free. Also, be sure to take in the Saturday Flea Market on the Square from 8:00 a.m. until the last buyer leaves. There are so many opportunities to buy some great Heisey glassware during our Convention.

Bryan has promised that the weather will be great during Convention, and we will hold him to that. We had a couple of days of frost warnings during May but by June the weather should be ideal. My garden has produced quite a few flowers already, and the tiger lilies are preparing for their grand display while you are here in Newark.

I have installed a new display at the Midland Theater which is located on the square here in Newark. This time we are featuring Heisey's all time best selling etchings, 509 Orchid and 515 Heisey Rose. Do stop by while you are in Newark to see the display and to take a look at this great old, completely restored theater.

I want to give a special thank you to those who contacted me about the list of Heisey etchings that I published in my last month's column. So many of you have been most generous in filling in some of the gaps in the collection in order that we can show off more examples of Heisey craftsmanship during the Convention seminars. It is much appreciated.

Bill Krall, as a representative of the Krall family, brought down 25 outstanding examples of Willibald Krall's exquisite cuttings on Heisey pieces. Willibald took over as foreman of the Heisey cutting shop after his brother Emil left to set up his own shop. Willibald produced outstanding pieces. He is especially known for his cuttings of oriental scenes. We have many examples of this work in the exhibit, as well as some truly amazing floral and geometric work. These will be on loan to the Museum for the next six months with the display opening during Convention. Please make a special effort to visit our Hospitality Room where these pieces are being exhibited.

I am pleased to announce that we will have a reprinting of the "Encyclopedia of Heisey Glassware: Etchings and Carvings, Second Edition" by Louise Ream and Neila and Tom Bredehoft available for sale during Convention. We should also have a very limited number of a reprinting of Catalog and Price List #31 from September, 1950 available for purchase. This catalog has never been reproduced before. The reprint has been produced by Dennis Headrick, HCA member from Oregon. Another item that we hope to have by Convention is Heisey note cards which feature vignettes of Heisey etchings as the design elements on the cards. All of these items are being produced not only to provide you with useful tools for your Heisey hunting, but also to support the Museum in its efforts to keep its budget balanced. We appreciate all of your support.

One of the greatest opportunities to acquire Heisey glass is about to happen right here in Newark in mid-June. I hope that many of you will be able to join us for Convention this year. The Heisey will be outstanding (as it always is). If you are not able to make it, we will miss you; but do get out there and find something great to add to your collection. Remember Heisey will not find you; you have to get out there and find it. ♦

HCA WELCOMES NEW MEMBERS FOR April 2009

Gerry Dush, OH
James, Shirley, and Elizabeth
Kelly, VA
Zach Ogle, OH
Peg Smith, WA
Lydia Wareham, OH

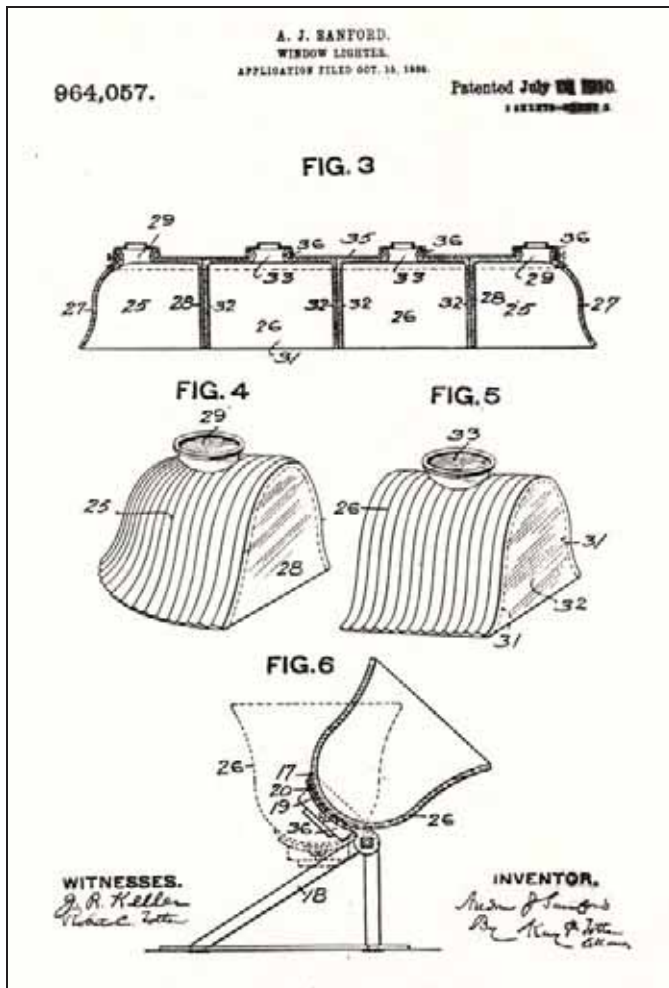

Patent 954,057

UTILITY PATENTS ASSOCIATED WITH A.H. HEISEY & COMPANY (PART 4)

Walter Ludwig

Our next series of utility patents were granted in the period 1909 to 1912. They range from basic improvements in the fire polishing of glassware to lighting fixtures. There is even one for an innovation to the crushed fruit design for which you can see the patent illustration on the cover of this issue.

The first patent we will look at is Patent 964,057 which was granted to Andrew J. Sanford of Newark, OH, assignor to the A.H. Heisey & Co, Inc., of Newark, OH. The patent was applied for on October 15, 1909 and was granted on July

12, 1910. This patent covers an innovation in a window-lighter.

The text says that, "my invention relates to glass shades and supporting devices therefore, and especially to that type employed for lighting window, pictures and the like. Its object is to provide a device of the character described, hereinafter termed a window lighter, suitable for carrying more than one electric light so as to distribute the light thoroughly in the desired direction, and to provide a shade in the device of simple construction and of desired length." The device consists of "an oblong glass shade, or oblong integral shade adapted to carry a plurality of lights or bulbs in a convenient manner and provide with a plurality of necks corresponding to the number of bulbs and adapted to support the same and to be attached to the improved shade carrying and adjusting device in my invention constituting with the shade the complete window lighter."

As you can see from the illustrations this looks like a shade that might have been made by the Holophane Company. We do know that in this period Heisey was making the Holophane shades, so it is possible that Sanford and Heisey were coming up with some innovations that were marketed by Holophane. The illustrations make the devices appear bigger than they would be if they were only intended to surmount a picture frame. I, personally, have never seen anything like what is illustrated.

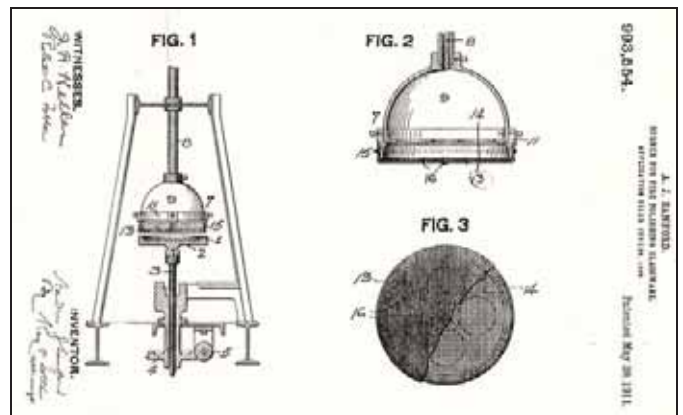

Patent 993,554

Next, we have two patents that were granted on May 30, 1911, for a burner for fire-polishing glassware (Patent 993,554) and for a method of fire polishing glassware (Patent 993,555). Again Andrew J. Sanford assignor to A. H. Heisey & Co is listed as the inventor.

The new burner "comprises a suitable burner body and a burner face supported thereby and adapted to provide multitudinous jet orifices for the flame jets consisting in asbestos cloth in combination with and supported by a sheet of wire netting attached to the burner body."

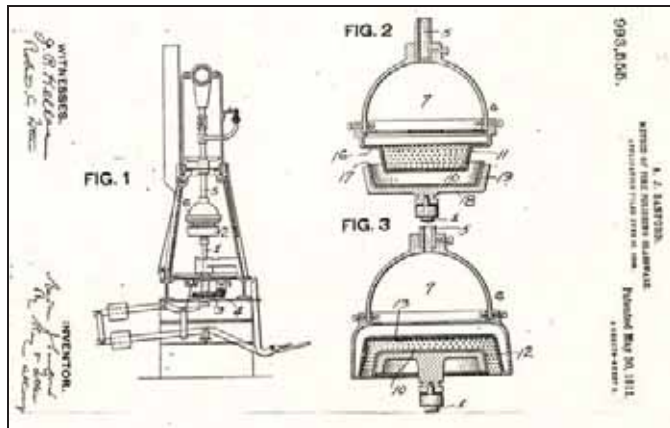

Patent 993,555 – Illustration 1

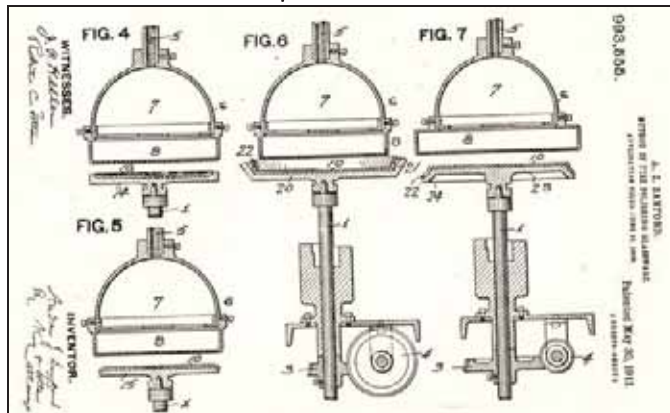

Patent 993,555 – Illustration 2

The new method of fire polishing dealt with "flat articles or articles having flat body portions with shallow upwardly projecting rims or sides" and the fire polishing of both the upper and lower surfaces. The article would be supported "upon a suitable former and first exposing the top surface thereof to a downwardly projecting fire polishing flame, and then reversing the article and fire polishing the bottom face thereof."

"It also consists in fire polishing such articles having flat body portions while so supporting the entire flat body portion and thereby preventing the sagging or stretching of the mid-portion of the flat body."

"It also consists in so fire polishing the top face of articles having upwardly projecting rims and at the same time rotating the articles so as to flare the rim portions outwardly, and then supporting the blank with its bottom face upward upon a former corresponding to the exact shape of the interior of the finished article and by the heat of the flame causing the rim portion of the article to conform to such outer portion of the former and produce an article of the exact shape desired."

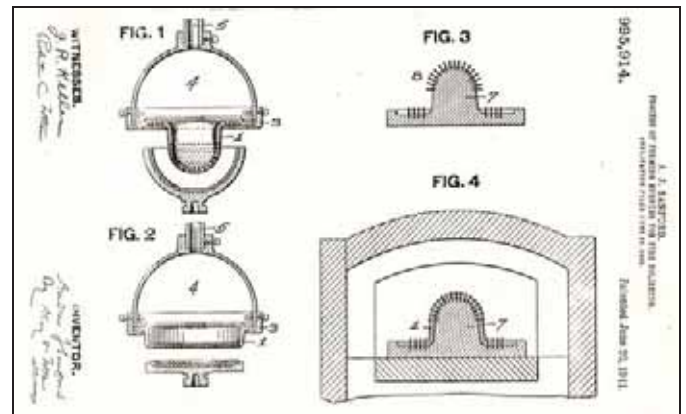

Patent 995,914

The final patent that dealt with fire polishing in this period was Patent 995,914 granted on June 20, 1911 to Andrew J Sanford assignor to A. H. Heisey and Co. The title of the patent is "Process of Forming Burners for Fire-Polishing." In this patent the goal was to make "a durable burner of the type which will withstand the very high heat generated upon the jet face thereof, for use for example, in connection with a method of fire polishing" as explained in the two previous patents presented here. The burner shall have "multitudinous jet orifices formed therein so as to provide for a multitude of small jet flames which can be projected directly against the surface to be polished, and the object of the present invention is provide a burner formed of refractory material such as

plumbago, or like baked clay, to withstand high heats."



353 Medium Flat Panel Crushed Fruit

The next utility patent is probably the most interesting of the ones we have looked at to this date. You will find the illustration for Patent 1,021,004 on the cover of this issue. The patent was applied for on August 16, 1910 but was not granted until March 26, 1912. The item being patented is simply described as, "Bowl." Andrew J. Sanford is again listed as the inventor with the invention assigned to A. H. Heisey & Co. The description follows:

"My invention relates to bowls or jars and particularly to those employed for carrying crushed fruit, preserves and the like. Its object is to provide an improved receptacle of this nature, ordinarily employed to carry crushed fruit and sticky or semi-liquid food, and with which a ladle or spoon is necessarily employed in removing the contents, which vessel is provided with means for removing the surplus fruit or the like from the bottom of the ladle, and returning it to the body of the bowl, thereby preventing waste and keeping the upper part or edge of the bowl clean.

"To these ends my invention consists, generally stated, in a bowl of this character provided with

a flange carried in its side portion and preferably having one or more inclined sides and other means hereinafter described to provide for the return of the surplus fruit or the like to the body of the bowl."

We do know that Heisey did produce a 2 quart sanitary crushed fruit based on this patent. The actual piece does not look identical to the patent drawing but is much more in keeping with the esthetic of Heisey's colonial lines. This crushed fruit is in the 353 Medium Flat Panel pattern. It is much harder to find than the more common 352 Flat Panel crushed fruits.

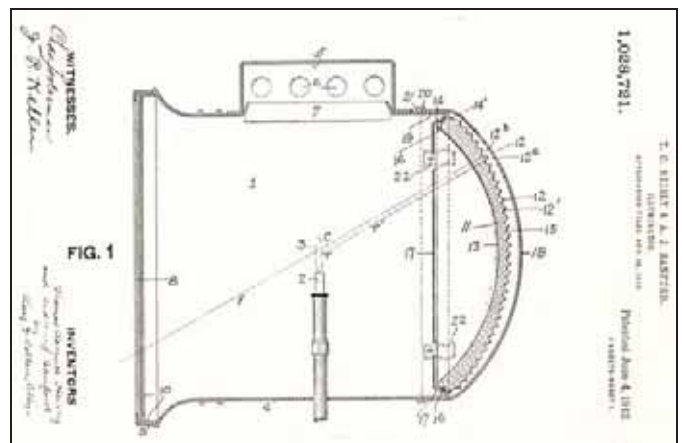

Patent 1,028,721 – Illustration 1

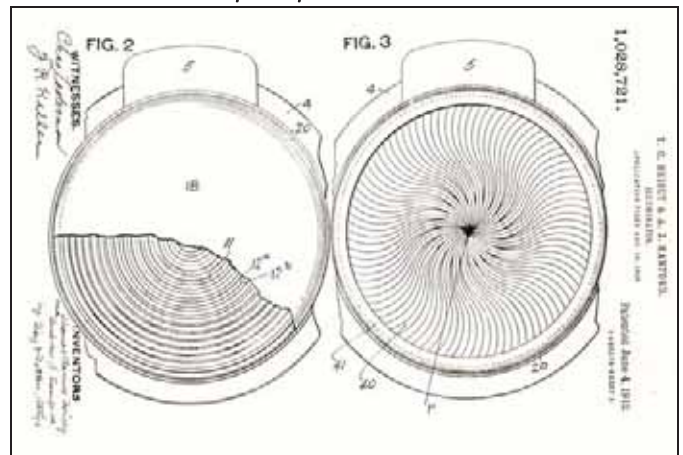

Patent 1,028,721 – Illustration 2

Our final utility patent that we will discuss in this article is Patent 1,028,721 which was granted on June 4, 1912 and is listed as an Illuminator. The inventors of this item are noted as Thomas Clarence Heisey and Andrew J. Sanford, both of Newark, OH, and assigned to A. H. Heisey & Company. This is the first time

that we note T. Clarence's name on any of the patents which we have looked at. He would have been 28 when this patent was applied for in 1910.

"Our invention relates to illuminators in general, and particularly to that class of illuminators used as head lights or search lights for automobiles, motor boats, or locomotives. Its object is to dispense with the metallic or mirrored reflector hitherto employed in the rear of the source of light to direct the rearwardly emitted rays forwardly through the glass pane or other diffusing device employed, and to substitute therefore a reflector which dispenses entirely with a mercury or other mirror, and has a relatively indestructible reflecting surface.

"To this end our invention comprises an illuminator having a casing with an annular flange at its rear portion, a reflector provided with an annular edge similar in shape to said flange, and a gasket of elastic material between the flange and the reflector edge."

We have no record of this "illuminator" ever being produced. This would have no connection to the prototype headlight lenses that we do know that the company made but which were never put into production. These probably date to the 1920s, at least ten years after this patent was granted.

We have one more installment on the utility patents to finish off this series of articles. The last one we have records of was granted in 1917. Next month we will cover a patent on the sanitary syrup and several on electro-portable lamps. ♦

429 PLAIN PANEL RECESSED

Joe Lokay

Production of 429 Plain Panel Recessed started about 1909 and ended about 1926. A total of 37 different items were offered over the life of the pattern. The first Heisey Price List (1910) to include 429 offered only seven items. By 1913,

33 items were offered in the pattern. In about 1915, 3 punch bowls, either with a base or without, were added to the pattern, and a 4 oz. parfait was added in 1916. From here, items were periodically discontinued until the pattern ended.

Among the interesting items in this pattern were the crushed fruit jars. They were offered in two sizes, one quart and two quart. A second set of crushed fruit Jars was offered in the same sizes, 1 and 2 quart, and they were given number 429 ½. From the price lists one can not tell the difference between the two types of jars. The 429 crushed fruits are in the same proportions as the 352 Flat Panel crushed fruits, but the 429 ½ versions are squat versions with the same designs. Heisey made two similar versions of the 602 crushed fruit.



Ad from Confectioners Journal April 1914
Showing 429 ½ and 602 ½ Crushed Fruits

The pattern offered 11 nappies and trays, 4 sizes of jugs, a tumbler and ice tea, four pieces of stemware, salt or pepper with four different tops, a footed individual salt, and punch cup (custard) and 3 punch bowls. There was no four piece table set, only a hotel cream and sugar with cover.

Plain Panel Recessed was unusual in that there were four design patents applied for and granted for this pattern. The first was applied for on March 10, 1910, and was granted on May 10, 1910, as Patent #40,686 for the hotel sugar. The cover was not included in the patent picture.

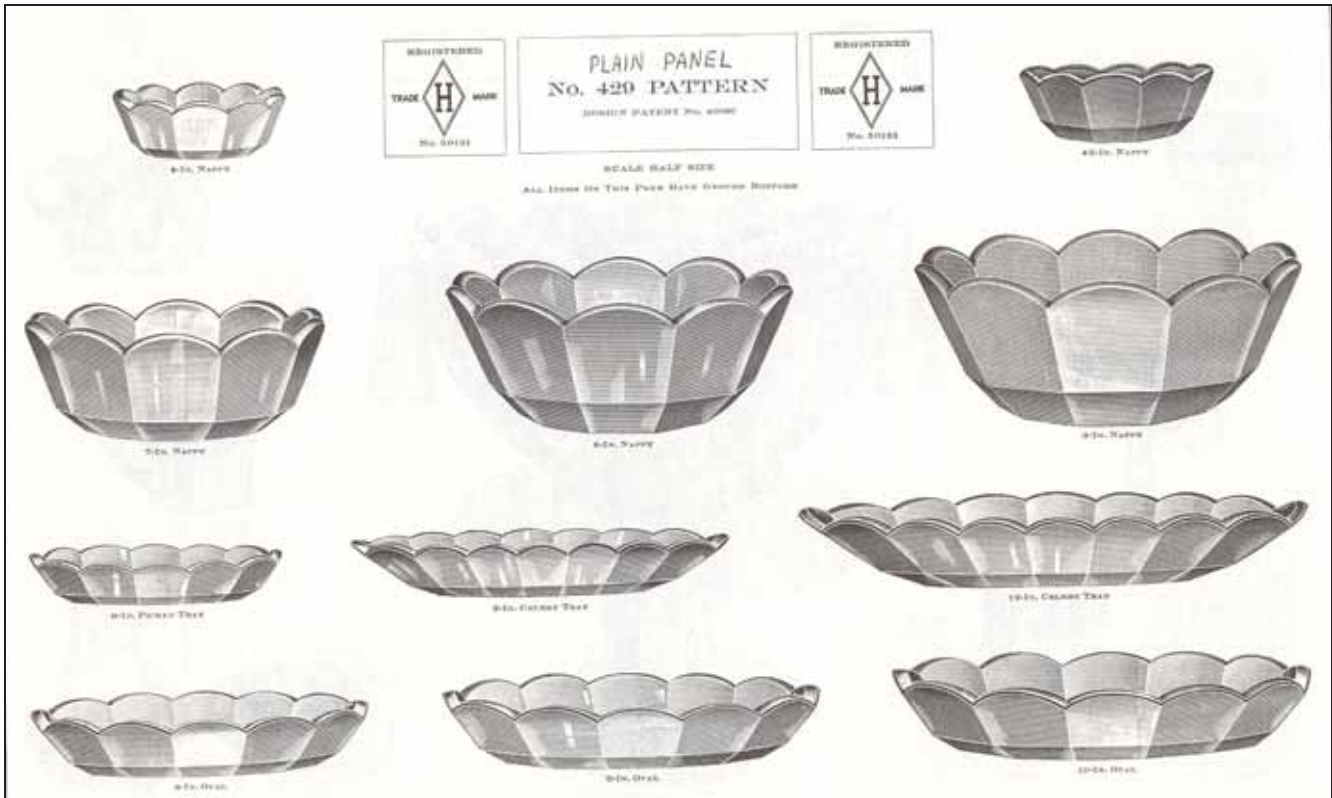

429 Plain Panel Recessed – Catalog 75 - page 235, Vogel II – page 64



429 Plain Panel Recessed – Catalog 75 - page 236, Vogel II – page 65

The second was Design Patent #43,437 for the crushed fruit Jar. The third was Design Patent #43,703 for the tumbler. The last was Design Patent #43,853 granted on April 15, 1913, for the oil bottle or cruet. The #28 salt shaker which has a design very similar to 429 Plain Panel Recessed was patented with Design Patent #43,781. It was never included in pattern 429, however. In the salt or pepper lists in Heisey Catalog #75, it was included as just #28. (See Heisey News, October 2007 for an article on this interesting salt shaker.)

Heisey's pattern 429 Plain Panel Recessed is a typical colonial pattern with wide flat panels, sometimes with scallops around the top edge. This plainness may have helped in selecting a name for the pattern. The main identifying feature of the pattern is the sharply defined inward angle near the bottom as you approach the bottom of each panel. Where applicable, a Heisey star is in the bottom of the item. This pattern was made only in Crystal and is typically signed with the Diamond H. The Heisey Company did not name the pattern. It was named by Clarence Vogel, early Heisey researcher.

This is a pattern that is neglected by many collectors, but there are some interesting pieces in it. Maybe you can find a bargain when you are Heisey hunting with a piece of 429.

Production of 429 Plain Panel Recessed

1. nappy, 4"
2. nappy, 4 ½"
3. nappy, 7"
4. nappy, 8"
5. nappy, 9"
6. pickle tray, 6"
7. oval, 8"
8. oval, 9"
9. oval, 10"
10. celery tray, 9"
11. celery tray, 12"
12. crushed fruit, 1 quart
13. crushed fruit, 2 quart
14. crushed fruit, 1 quart (429 ½)
15. crushed fruit, 2 quart (429 ½)

16. jug, 1 pint
17. jug, 1 quart
18. jug, 3 pint
19. jug, ½ gallon
20. tumbler, 8 oz.
21. tumbler, ice tea, 12 oz..
22. goblet, 7 oz.
23. egg cup, 5 oz.
24. parfait, 4 oz.
25. sherbet, 4 oz, straight
26. sherbet, 4 oz., flared
27. custard, 4 oz.
28. punch bowl, 15" with or without base
29. punch bowl, 16", flared with or without base
30. punch bowl, 17", shallow with or without base
31. individual salt, footed
32. salt or pepper, No 1. with no. 1 sanitary top
33. salt or pepper, No. 3 with no. 2 or no. 3 sanitary top, or no. 43 top, or nickel top
34. oil, pressed or cut stopper
35. finger bowl.
36. Sugar, hotel with cover
37. cream, hotel

References

1. Heisey Price List #155 (1910)
2. Heisey Price List #175 (1913)
3. Heisey Catalog #75 (1913) pages 235-237
4. Heisey Catalog #76 (1915) pages 24, 30
5. Heisey Price List #179 (1916)
6. Heisey Price List #200 (1917)
7. Heisey Price List #205 (1919)
8. Heisey Price List #206 (1922)
9. Heisey Catalog #100 (1922) pages 117-119
10. Heisey Price List #208 (1924)
11. Heisey Catalog #102 (1924) pages 113-115
12. Heisey News, June 1975, 429 Salt or Pepper
13. Heisey News, Feb. 1977, 429 Tumbler
14. Heisey News, March 1977, Pattern #429
15. Heisey News, Oct. 1984, #429 Little Things
16. Heisey News, Sept. 1986, Chronology 1910-1917
17. Heisey News, Nov. 1991, #429 Design Patents
18. Heisey News, Dec. 2004, 429 ½ Crushed Fruit
19. Vogel Book II pages.64-66, 152 ♦

462 & 462 ½ NAIL

449 & 450 NAIL

Joe Lokay

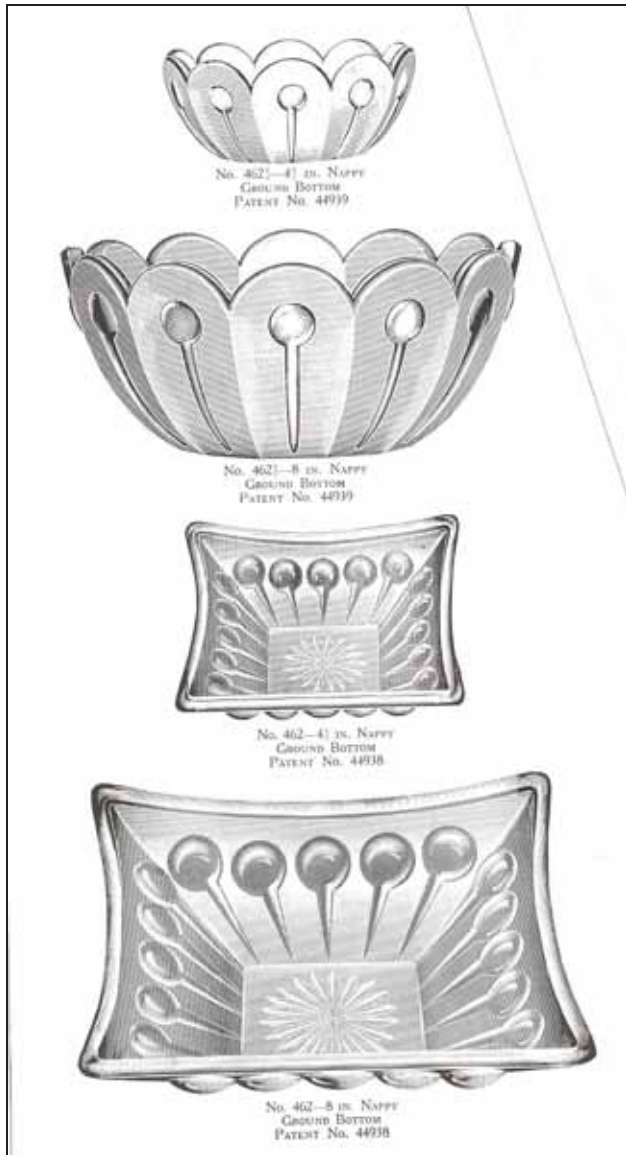

462 and 462 ½ Nail Nappies

The 462 Nail pattern was a very small line consisting of only four nappies, two round and two square. The pattern was not offered in any of the Heisey Price Lists that we know about. It was first pictured in Heisey Catalog #76, circa 1915. Catalog #76 is a small supplement to Heisey's big Catalog #75, circa 1913. Heisey filed for two design patents in this pattern, one for the square nappy and the second one for the round nappy. The two applications were filed on October 8, 1913, and both were granted on November 25, 1913. The square nappy is design

patent #44,938 and the round nappy is design patent #44,939. The square nappies were given pattern number 462, while the round nappies assigned number 462 ½. Both styles may be seen on display in the Museum.

Given the patent information, it is estimated that production of the Nail pattern started in 1914. Nail was not in Heisey Price List #179, circa 1-1-1917. So it is estimated that production ended in 1916. Thus, the pattern life was about 2-3 years.

The overall design is plain as there are no colonial features such as panels or scallops. The design elements around the body are raised areas that look like nails or ice cream cones. There is no other design except for the typical Heisey star in the bottom. They were made in crystal only, and are signed with the Diamond H. Clarence Vogel named the pattern Nail.

There are two vases that have the same nail design, but Heisey gave them different catalog numbers. They are also pictured in Heisey Catalog #76. The production life of the two vases was also for 2-3 years.



449 Nail Vase



No. 440-8 in. Vase
Optic
Also Made Plain

440 Nail Vase, Optic

Heisey also used number 462 for the Plain Hexagon 8" basket. The basket body is 6-sided, and there are no nail designs. This basket was not part of the Nail pattern. Production of the basket started in 1916 and ended in 1932. It was made in crystal only and is signed with the Diamond H. It is unusual for Heisey to recycle a pattern number so quickly, but this may be the exception to the rule.

Production, 462 Nail

1. nappy, square, 4 ½"
2. nappy, square, 8"
3. nappy, round, 4 ½" (462 ½)
4. nappy, round, 8" (462 ½)

Production, 449 & 450 Vases

1. 449 vase, 10", plain
2. 449 vase, 10", optic
3. 550 vase, 8", plain
4. 550 vase, 8", optic

References

1. Heisey Catalog #76 (1915) p.22, 32
2. Heisey News, December 1975, Pattern #462, 462 ½
3. Heisey News, November 1979, 462 Basket
4. Heisey News, Sept. 1986, Chronology 1910-1917
5. Heisey News, June 1990, Pattern 462
6. Vogel Book II p. 172 ♦

371 SCALLOPED TOP CURVED

Joe Lokay



371 Scalloped Top Curved Nappies

The 371 Scalloped Top Curved pattern is only a line of nappies and plates. There are a total of 32 nappies and 16 plates.

- 8 regular nappies, 4 to 10 in., star bottom
- 8 cupped nappies, 4 to 10 in., star bottom
- 8 regular nappies, 4 to 10 in., plain bottom
- 8 cupped nappies, 4 to 10 in., plain bottom

- 8 plates, 4 ½" to 11", star bottom
- 8 plates, 4 ½" to 11", plain bottom

One nappy and a plate form a set. A set could have star bottoms or plain bottoms or mixed. A set could have a regular nappy or a cupped nappy.

Pattern 371 appeared in two Heisey Price Lists; #142 (1908) and #155 (1910). The pattern ended in about 1912. Thus, the production life of the pattern was about 5 years.

The pattern was a plain design with scallops around the top edge. There were no vertical panel lines with each scallop giving a plain, continuous surface around the inside and outside of the nappy. It was made in crystal only, and is signed with the diamond H. The pattern was named by Clarence Vogel.

The number 371 was used again by Heisey for a syrup that was shown in Heisey's 1924 Catalog. This syrup was registered by Heisey under design patent #60,378 granted in February 1922. This syrup was not part of the 371 pattern, but exists on its own.

Production of #371 Scalloped Top Curved Nappies

1. nappy, 4", star bottom
2. nappy, 4 1/2" star bottom
3. nappy, 5", star bottom
4. nappy, 6", star bottom
5. nappy, 7", star bottom
6. nappy, 8", star bottom
7. nappy, 9", star bottom
8. nappy, 10", star bottom
9. nappy, 4", cupped, star bottom
10. nappy, 4 1/2", cupped, star bottom
11. nappy, 5", cupped, star bottom
12. nappy, 6", cupped, star bottom
13. nappy, 7", cupped, star bottom
14. nappy, 8", cupped, star bottom
15. nappy, 9", cupped, star bottom
16. nappy, 10", cupped, star bottom
17. nappy, 4", plain bottom
18. nappy, 4 1/2", plain bottom
19. nappy, 5", plain bottom
20. nappy, 6", plain bottom
21. nappy, 7", plain bottom
22. nappy, 8", plain bottom
23. nappy, 9", plain bottom
24. nappy, 10", plain bottom
25. nappy, 4", cupped, plain bottom
26. nappy, 4 1/2", cupped, plain bottom
27. nappy, 5", cupped, plain bottom
28. nappy, 6", cupped, plain bottom
29. nappy, 7", cupped, plain bottom
30. nappy, 8", cupped, plain bottom
31. nappy, 9", cupped, plain bottom
32. nappy, 10", cupped, plain bottom

Plates

1. plate, 4 1/2", star bottom
2. plate, 5", star bottom
3. plate, 6", star bottom
4. plate, 7", Star bottom
5. plate, 8", star bottom
6. plate, 9", star bottom

7. plate, 10", star bottom
8. plate, 11", star bottom
9. plate, 4 1/2", plain bottom
10. plate, 5", plain bottom
11. plate, 6", plain bottom
12. plate, 7", plain bottom
13. plate, 8", plain bottom
14. plate, 9", plain bottom
15. plate, 10", plain bottom
16. plate, 11", plain bottom

References

1. Heisey Price List #142 (1908)
2. Heisey Catalog #56 (1909) p.85
3. Heisey Price List #155 (1910)
4. Heisey News, March 1979, Pattern #371
5. Heisey News, July 1986, Chronology 1904-1909
6. Heisey News, April 1987, #371 Syrup
7. Vogel Book II page 154 ♦

445, 1127, AND 1129 FINE TOOTH

Joe Lokay



445 Nappies

This is a group of patterns with only nappies and plates. The three patterns are identical in decorative design except Heisey gave them separate pattern numbers. They are now all known by the name Fine tooth. You will see the

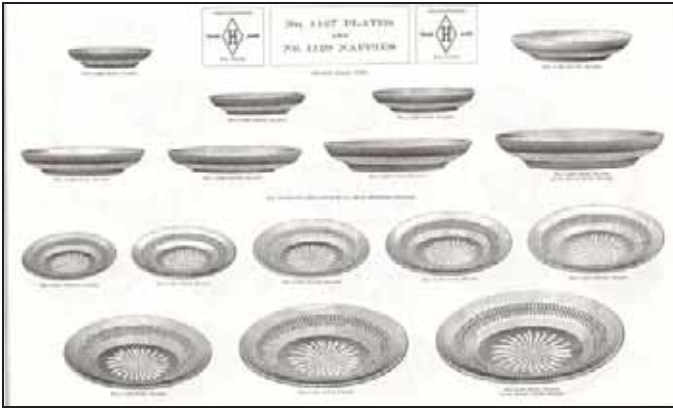

1127 Plates and 1129 Bowls

similarity when you look at the pictures for each pattern. The patterns are composed of:

- 445 - 5 nappies, 4 to 9"., star bottom
- 445 - 5 nappies, Shallow, 4 ¾ to 10", star bottom
- 1127 - 9 plates, 4 ½ to 10", star bottom
- 1129 - 9 nappies, 4 to 9", star bottom

The sides of the 445 nappies curve out like a half grapefruit. The sides of the 1129 nappies curve in first for about ½ way up the height and then curve out to the top. One mold would be used to produce the nappies and plates with the plates being slightly larger in diameter. The factory would have used a metal former to achieve the desired curve on the sides of the bowls. All the pieces have star and ground bottoms. They were made in crystal only, and are signed with the Diamond H. One nappy and a plate form a set. A set could have a regular nappy or a cupped nappy.

The three patterns appeared in only one Heisey Price List; #175 (1913) and in only one Heisey Catalog #75 (1913). The pattern ended in about 1915. Thus, the life of the patterns was about 4 years.

The pattern was a plain design with what looks like a cut horizontal line with finger flutes cut across this line. Of course, this is a molded pattern and no cutting was done to achieve the effect. There were no vertical panel lines or scallops giving a plain, continuous surface from the circumference of the bottom diameter to the

top or outer edge for the fine tooth band. The Heisey Price List makes reference to the pattern with sawtooth bands. Vogel named the patterns Fine Tooth.

Production items of 445 Fine Tooth

1. nappy, 4"
2. nappy, 4 ½"
3. nappy, 7"
4. nappy, 8"
5. nappy, 9"
6. nappy, 4 ¾", shallow
7. nappy, 5 ½", shallow
8. nappy, 8" shallow
9. nappy, 9", shallow
10. nappy, 10", shallow

Production of items of 1127 Fine Tooth

1. plate, 4 ½"
2. plate, 5"
3. plate, 5 ½"
4. plate, 6"
5. plate, 6 ½"
6. plate, 7"
7. plate, 8"
8. plate, 9"
9. plate, 10"

Production of items of 1129 Fine Tooth

1. nappy, 4"
2. nappy, 4 ½"
3. nappy, 5"
4. nappy, 5 ½"
5. nappy, 6"
6. nappy, 6 ½"
7. nappy, 7"
8. nappy, 8"
9. nappy, 9"

References

1. Heisey Price List #175 (1913)
2. Heisey Catalog #75 (1913), pages. 89, 258 ½
3. Heisey News, March 1979, Pattern #445, 1127, 1129
4. Heisey News, Sept. 1986, Chronology 1910-1917
5. Vogel Book II pages 128, 135 ♦



HEISEY GLASS MUSEUM PLAYING CARDS

Edition 3 (green deck) of Heisey Glass Museum Playing Cards are now in. In addition, we have for sale a limited number of uncut sheets (21" x 25") which will be suitable for framing. This deck features the Heisey animals and animal related items. The full color pictures are stunning and will make a good learning tool as well as a nice gift for all of your glass collecting friends. We will ship as soon as available. Orders for Card Cases (Cobalt) and the Red deck may also be placed on this form.

Name _____
 Address _____
 City _____ State _____ Zip _____

Phone and/or E-mail _____

I wish to order:	Total
_____ (number) Heisey Glass Museum Playing Cards (Green) @ \$10 each	_____
_____ (number) Heisey Glass Museum Playing Cards (Red) @ \$10 each	_____
Shipping per deck \$ 1.50 (can be picked up at Gift Shop)	_____
_____ (number) Uncut sheets of Heisey Playing Cards (Green) @ \$25 each	_____
_____ (number) Uncut sheets of Heisey Playing Cards (Red) @ \$25 each	_____
Shipping per uncut sheet @ \$5.00 each (can be picked up at Gift Shop)	_____
_____ (number) 1508 Card case in Cobalt @ \$24.95 each	_____
Shipping per card case @ \$6.00 each (can be picked up at Gift Shop)	_____
Grand Total (tax will be added when appropriate)	_____

Check # _____ Visa _____ Master Card _____
 Card Number _____ Exp _____

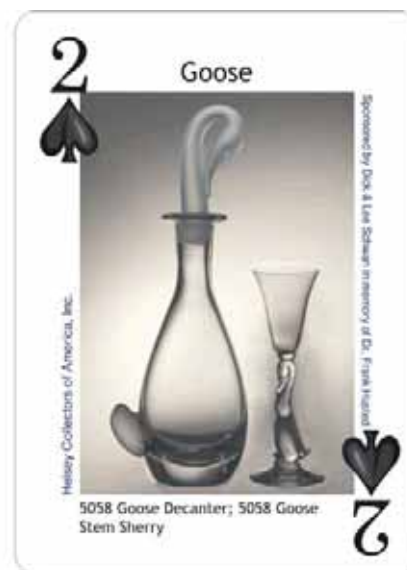
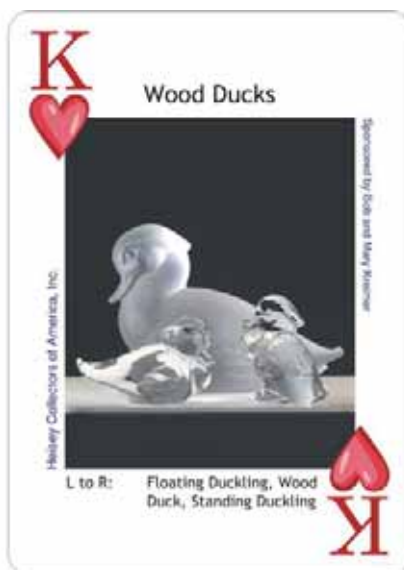
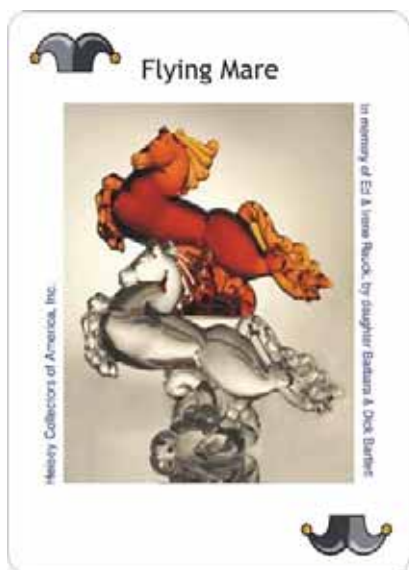

2009 HCA CONVENTION NEWS

Judy Rhoads & Mary Ann Spahr, Co-Chairs

**CONVENTION REGISTRATION DEADLINE:
June 4!!!!**

STUDY CLUB REPRESENTATIVES MEETING
Bryan Baker

HCA Chartered Study Clubs are a significant part of our organization. This meeting is a great opportunity for representatives of HCA Chartered Study Clubs to gather together and share ideas, current/past projects, and trends with each other and members of the Board of Directors. What fun events and programs is your club engaged in? Want to share it with other clubs? How are you acquiring new members? Well, this is your time to share and also to learn from others. It is also a time when the Board of Directors can hear from your club. Please make sure you send a representative from your Study Club to this valuable meeting Thursday, June 18 at 10 AM. It'll just be "You, Me, Us"!

PREMIER GLASS SHOW & HCA BOOTH
Sharon Orienter and Robert Loch

We Heisey lovers search all year for just the right piece of Heisey to fit in our collections. Whether a new or a long-time collector, looking for and finding a new piece is a treat for us all.

Imagine walking into a room that sparkles wall-to-wall with shelves full of gorgeous Heisey glass - Welcome to the annual HCA Convention Premier Glass Show and Sale! Dealers from around the country have searched all year to offer you the very best choice of the most beautiful glass available. Come and see what the dealers have selected to tempt you!

Once again we will be offering a door prize drawing of \$25 gift certificates donated by the show dealers.

Be sure to stop by the HCA Booth at the show! Congenial folks you may already know, including members of the HCA Board of Directors, will staff the HCA Booth. This is your chance to shake hands and chat one-on-one for a few minutes, ask them a

question you may have about the HCA organization, or make suggestions about HCA.

The HCA Booth will have a number of Museum gift shop items for sale including the new Animal Edition of the Heisey Museum Playing Cards, our picture postcards, some newly reprinted books, our latest tumblers and figurines, and other souvenirs of our Museum and your trip to Newark.

The HCA Booth will be open during show hours. Study clubs are invited to bring any printed information about your club to be available in the booth.

HCA ANNUAL MEETING
Bryan Baker

Who says you can't mix business with pleasure?! With all the events during Convention - the Glass Show, Seminars, ID Session and Show & Tell, and more - we still have business to conduct...our Annual Meeting. This is where we report to the membership the state of our organization, including our financial standing, maintenance needs, and current and future projects. What makes this meeting even more important is the election of officers to our Board of Directors. Voting members cast their ballots for their candidates of choice (absentee ballots available upon request as always). Our new Directors are sworn in, and thus begins a new Board to lead the organization for the upcoming year. This is also when Study Clubs and members alike make their presentations to HCA. Never to worry, the meeting is typically over well in time to grab a quick bite to eat before heading back over to the phenomenal Glass Show!

BRING on the MUNCHIES!
Karen Clark / Pat Moore

While you are packing for your trip to Newark, don't forget to include goodies for the Hospitality Room. Nuts, pretzels, crackers, homemade cookies, perhaps something special from your area of the country would be appreciated by hungry Convention-goers! Also appreciated would be monetary donations since ice, pop, fresh fruit, and bottled water are always last-minute purchases.

Karen and Pat will welcome all donations. You can E-mail Karen at karen9132@prodigy.net or Pat at pmoore42@columbus.rr.com. ♦



38th Annual Convention
HEISEY COLLECTORS OF AMERICA, INC.
 JUNE 17-20, 2009

"Artistry in Glass: the Heisey Etchings"

SCHEDULE of EVENTS

Event	Time	Location
WEDNESDAY, June 17		
Registration Pickup	2:00 - 5:00 p.m.	Museum
<i>"Tally Ho"</i> ...and off we go ... Welcome BBQ	5:30 p.m.	{ Rotary Park Sharon Valley Rd Newark
Museum "Heisingo"	8:00 p.m.	

THURSDAY, June 18		
Registration Pickup	10:00 – Noon	Museum
<i>"You, Me, Us!"</i> Study Club Representatives meeting	10:00 - 11:00 a.m.	Founders Hall Auditorium
Glass Show tickets sales begin	11:30 a.m.	Adena Hall, OSUN/COTC
Show Preview (<i>Convention Registrants Only</i>)	Noon - 1:00 p.m.	Adena Hall
Glass Show open – General Admission	1:00 - 7:00 p.m.	Adena Hall
Registration Pickup	1:00 - 4:00 p.m.	Adena Hall
Seminar	3:00 p.m.	Adena Hall
Glass Identification Session / Show & Tell	8:00 p.m.	Founders Hall Auditorium

FRIDAY, June 19		
<i>"Good Morning"</i> Annual General Membership Mtg	8:30 a.m.	Founders Hall Auditorium
(Polls Open 8:30 a.m. – 9:00 a.m.)		
Glass Show open – General Admission	Noon - 5:00 p.m.	Adena Hall
Former Employees Reunion	1:00 - 2:00 p.m.	Museum
Seminar	3:00 p.m.	Adena Hall
<i>"Tavern"</i> Cocktails (cash bar)	6:00 - 7:00 p.m.	{ The Crystal Ballroom 29 W Church St Downtown Newark
<i>"Classic"</i> Heisey Banquet / Special Auction	7:00 p.m.	

SATURDAY, June 20		
Flea Market on the Square	8:00 a.m. – Noon	Courthouse Square Downtown Newark
Glass Show open – FREE ADMISSION	Noon – 5:00 p.m.	Adena Hall

OPEN HOUSE

The National Heisey Glass Museum
 Tuesday – Saturday, June 16-20, 10:00 a.m.- 4:00 p.m.
 Sunday, June 21, 1:00-4:00 p.m.

Hospitality in Multipurpose Room, Thursday & Friday, 10:00 a.m. – 4:00 p.m.

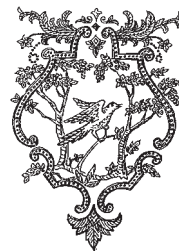

HCA CONVENTION 2009 REGISTRATION FORM

REGISTERING IS EASY !

Forms are available in your Heisey News and online at www.HeiseyMuseum.org

1) **Mail** forms to Convention Registration, 169 W Church St, Newark OH 43055; 2) **Deliver** forms directly to the Museum; 3) **Phone** in registration information at 740-345-2932; or 4) **Fax** forms to 740-345-9638 !

- ◇ **Registration deadline Thursday, June 4**, for all food events. Sorry, **no registration refunds after June 8** when final counts are taken!
- ◇ If you are not registering the same people for all events, or individuals are from different locations, please fill out a separate form for each person.
- ◇ If you want notice of confirmation, you must include a SASE or provide an E-mail address below.

Please print each name as it should appear on their badge:

Name(s): _____

Address: _____

City / State / Zip _____

Phone: (____) _____ E-mail: _____

Check here to receive E-mail confirmation of your registration

IS THIS YOUR FIRST HCA CONVENTION? _____ WOULD YOU LIKE A MENTOR? _____
 OLD TIMERS, PLEASE APPROXIMATE the YEAR OF YOUR FIRST CONVENTION ! _____

PAYMENT: Cash Check
 MasterCard Visa # _____ exp _____

Event	How Many?	Cost	Subtotal
Registration Fee (Deadline Thursday, June 4)	_____ X	\$25 =	_____
*Welcome BBQ, Wednesday, 5:30 p.m. <i>Pulled Pork, BBQ Beef, Sweet Corn Bake, Baked Beans, Tossed Salad, Potato Salad, Watermelon, Rolls, Cobbler</i>	_____ X	\$12 =	_____
Thursday Seminar: "The Heisey Etchings"	_____	FREE	
*Glass ID Session / Show & Tell	_____	FREE	
Annual Meeting, <i>Open to all HCA Members</i>	_____	FREE	
*Former Employees Reunion	_____	FREE	
Friday Seminar: "The Heisey Etchings"	_____	FREE	
*Heisey Banquet / Auction, Friday, 6:00 p.m. <i>ROAST BEEF AU JUS, CHICKEN CORDON BLEU, TOSSED SALAD, ROASTED RED POTATOES, VEGETABLE MEDLEY, DESSERT</i>	_____ X	\$25 =	_____
Flea Market on the Square	_____	FREE	
Hospitality Room, Thursday & Friday at Museum	_____	FREE	

**You must be registered to attend these events !*

TOTAL = \$ _____

Newest Designs in Etched Glass

THE new designs that Heisey is showing this Spring are so graceful in shape, have such delicate designs etched on the thin glass that you sigh to think how expensive it must be!

But it is so *inexpensive* you can make your table beautiful with many different pieces. And it is such a *gem* to own and use! For if an accident breaks one lovely piece—its lovely duplicate is waiting at your dealer's at such a low cost you would not dream of worrying over it.

At your dealer's or sent direct

See at your dealer's dozens of beautiful and useful things for your table. If

A set of goblets like this gives a charm and richness to your table that only the sparkle of fine glass can



your dealer cannot show you Heisey's Glassware, accept no substitute, but write and we will see that you are supplied with genuine Heisey's Glassware. For sale only at the better stores.

Free illustrated book

Write for our booklet, "Table Glass— and How to Use It." It shows Heisey's Glassware so clearly that you feel quite safe in ordering by mail. It tells you how to make your table more beautiful at surprisingly low cost. A. H. Heisey & Company, Dept. 57, Newark, Ohio.

In the center below is shown a high footed mint of exquisite design. In Heisey's Glassware you are sure of correctness of style.



TRADE MARK

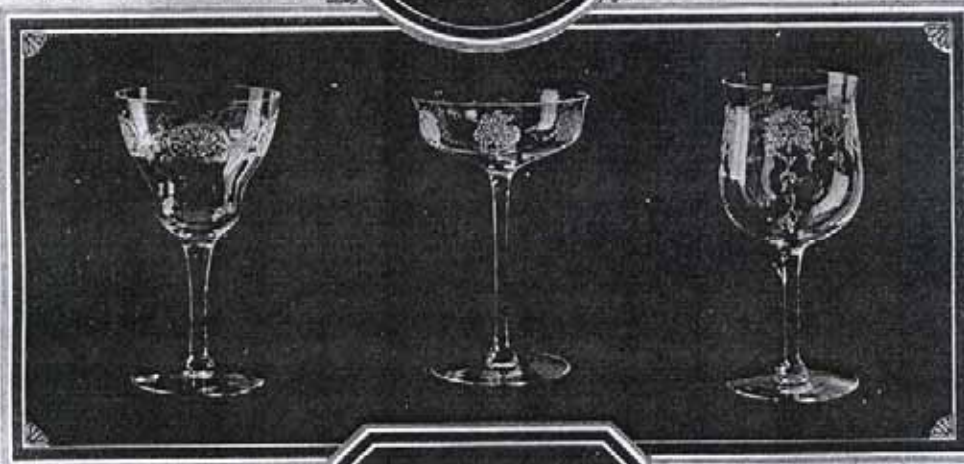

TRADE MARK

You can use this lovely tableware at every meal; it is so inexpensive to replace.



You take more delight in serving iced tea to your guests, when they exclaim over your lovely pitcher and glasses.



Heisey's Glassware is always easy for you to get. If your dealer hasn't it in stock and will not get it for you, write us for the design you wish.

Cups, salad bowls, goblets—and many other things—delight us in this stunning glass.



Remember, there is no better glassware made and, considering attractiveness, durability, etc., it is the most inexpensive you can buy.

HEISEY'S GLASSWARE

TRADE MARK

FOR THE TABLE

ON EVERY PIECE

ON EVERY PIECE

The New Diana Goblet

CHARACTERISTIC of all blown stemware bearing the Heisey  hall-mark is this new creation possessing not only amazing brilliance and beauty but the clear ringing tone that is distinctly a Heisey attribute. Replete in the charm of the Jacobean period it is embellished in a beautiful two-tone etching featuring the exploits of the famous allegorical heroine Diana. ❖ ❖

At the better stores or write

Dept. 63 A. H. HEISEY & CO. Newark, O.

HEISEY'S
TRADE  MARK
GLASSWARE

FOR YOUR TABLE

ETCHINGS ADS

Walter Ludwig

Shown on this page and the previous page are two early ads for Heisey etchings. Several are shown in the ad on page 20 including 412 Hermitage (top), 411 Sabrina (center left), and 411 Lansdowne (rest of center row and

tumblers). The center bottom is 657 Liberty cutting. This May 1918 ad is multi-colored and printed with a yellow background.

Above we have an ad from May of 1925 for the 442 Diana double plate etching. Both ads appeared in high circulation magazines of the time. ♦

Study Club Directory

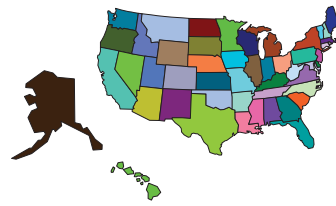

Interested in joining a study club? You will have the opportunity to meet fellow collectors and HCA members and learn more about your favorite glassware. If your club is not listed or you need to make corrections to your listing, please contact the Museum.

STUDY CLUB	MEET WHEN?	WHERE?	Email/Web Site	CONTACT
#4 Central Illinois Helsey Collectors Club	Four times a year	Members' homes or restaurants		Joyce Deany (815) 432-4310
#5 Bay State Helsey Collectors Club	2 nd Tuesday of each month except July, Aug., and Dec.	Whole Foods Community Rm, Bedford, MA	spescatore@houghton.com	Stephen Pescatore (978) 256-5418
#7 Dayton Area Helsey Collectors Club	3 rd Tues. of the month Sept. to May, 6:30 p.m.	Huber Heights Library	LH937@aol.com	Joe Harner (937) 372-0852
#8 Helsey Heritage Society <i>NJ, Eastern PA and DE areas</i>	Four times per year	Members' homes	craigkratochvil@aol.com	Craig Kratochvil (973) 962-4004
#13 Helsey Club of California	4th Sunday every month, 12:30	Members' homes	herbet@sbcglobal.net www.helseyclubca.org	Norval Helsey (818)-349-0945
#14 Northern Illinois Helsey Club	Four times a year	Members' homes	nihelsey@comcast.net	Jeff Morrow (630) 833-4644
#15 Helsey Collectors Club of Michigan	Every six weeks, August to May	Members' homes	kilgoredesigns@att.net	Sue E. Kilgore (269)-345-3990
#16 Helsey Collectors of Texas	2 nd Sat. of every odd month except May 1 st Sat., 1 p.m.	Members' homes	sanddollars97@tx.rr.com www.helseycollectorsoftexas.com	Greg Freeman (817)-545-5889
#19 Helsey Collectors of the Rochester Area	10 meetings per year: Sunday, 2:30 p.m.	Members' homes	seo2@aol.com	Sharon Orienter (585) 288-8076
#20 Buckeye Helsey Collectors Club <i>Newark, OH area</i>	September to May, 4th Monday	Members' homes or the Museum	Theflyingmaher@webtv.net	Michael Maher (740) 763-4256
#22 Northwest Helsey Collectors	First Saturday of the month	Members' homes	bahama50@hotmail.com	Deborah de Jong (425) 868-0457
#25 Helsey 76'ers <i>Columbus, OH area</i>	Once a month, September to May	Members' homes	ldburg48@aol.com	Colleen Burgess (614) 882-1884
#31 Nassau Long Island Helsey Club	Generally every other month	Members' homes		Babs Kent (516) 228-8274
#32 Dairyland Helsey Club	Once every two months	Members' homes		Ray K. Courtnage (414) 962-9747
#33 Golden Gate Helsey Collectors Club <i>Northern California</i>	Quarterly	Members' homes		Russ Nicholas (916) 515-8558
#36 Helsey Club of Southern MA	April, June, September, December			Maria Martell (508) 833-0633
#38 North Carolina Helsey Study Group	6 meetings per year: Jan.; March, May, July, Sept., Nov.	Replacements Ltd Greensboro, NC	Nchsg@yahoo.com www.northcarolinahelseystudygroup.org	Karen Taylo (252) 637-9985
#39 Florida Helsey Collectors Club	4 times per year: January – February-March-April	Westchester Country Club Boyton Beach, FL	Shirley400@aol.com	Everett Dunbar (772)-337-1558
#42 Gulf Coast Helsey Club of Florida	Nov., Jan. and March; 2 nd Thursday 11:00 am	Members' homes		Jack Grenzebach (727)-391-5784
#43 Tri-State Helsey Study Club <i>OH, IN, MI</i>	1 st Sat. every 3 rd month	Members' homes	Maxwellm@cktech.biz	Mike Maxwell (260) 925-3484
#45 Hoosier Helsey Club	Four times a year	Warren Library, Indianapolis, IN		J. David Litsey, (317) 872-7800
#48 Dixieland Helsey Study Club	Odd number months, 2 nd Saturday night	Members' homes	www.dixielandhelsey.org	Craig German (770) 967-8733
#49 Great Plains Helsey Club	March, May, July, September, and November	Members' homes	cameron_mg@mchsi.com www.greatplainshelseyclub.org	Mary Cameron (515) 292-3743
#50 Northwoods Helsey Club of Minnesota	Four times a year	Members' homes	wheise@comcast.net	Bob Heise (952)-831-9335
#51 Helsey Club of Northeast Florida	Feb., May, Aug., and Nov. 2 nd Thursday	Avonlea Antique Mall, Jacksonville	Clasyglas2@aol.com	Barb Bartlett (904) 280-0450
#52 Northern Virginia Helsey Study Club	Monthly, Sept. – May	Members' homes	rreopell@verizon.net	Russ Reopell (703) 250-6117

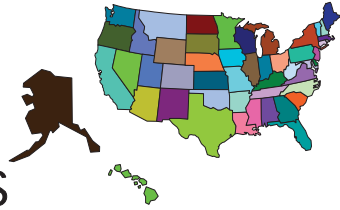

CLUB NOTES

Great Plains Heisey Club
Kathy Files

Not an elk in sight on May 9, 2009, when we convened our Great Plains Heisey Club meeting at the lovely home of Pat and Rex in Elkhorn, NE. There was Heisey to behold and members to visit with and even a guest or two in attendance. (Becky from the Denver area was visiting with Trudy; Paul from Lincoln, NE came for a visit and became our newest member. Welcome aboard!).

After a delicious lunch our meeting was called to order by Treasurer Tom Files in the absence of President John. The minutes from our previous meeting were approved and the Treasurer's report was given. Tom gave a recap of the successful April Benefit Auction held in Newark.

Trudy showed us a Glass Toothpick Holders book and we reviewed the Heisey section and admired the pictures. Member Jean Will invited everyone to her special 80th birthday party on May 24 in Leavenworth, KS. Congratulations to Jean for reaching this milestone. This is one of the few events in Leavenworth where you don't have to be indicted to be invited.

Our program on Heisey Winchester '73 etch was given by Mary since host Rex has a special interest in that silhouette etch and provided the crystal glassware examples. Mary also provided a cup and saucer from Vernon Kilns with their complementary Winchester '73 design. We all enjoyed Mary's comprehensive information and Gregg's Power Point visuals including the actual promotional preview of the movie shown in theaters back in the early 1950s. (There was no popcorn or jujubes but after a great lunch and knowing dessert was coming, we didn't miss those theater snacks). Winchester '73 was in the era of western movie good guys (the white hats of Hopalong Cassidy, Gene Autry, and Roy Rogers). The movie starred Jimmy Stewart and Shelley Winters. Good memories and a great program – thanks Rex, Mary, and Gregg.

Our Show and Tell was next. It appeared some of our snowbirds had cleared all the Heisey out of the Southern tier of states. Here's some of the pieces – sorry, I missed many items because I was enjoying instead of writing: 1567 Plantation non-matching candleblocks, 1567 Plantation round butter, 150 Banded Flute water bottle, 305 Puntly and Diamond Point items -- sugar shaker, cologne, toothpick, and spoon, 500 Octagon basket/Flamingo, 339 Continental toothpick, 1405 Ipswich candlestick and cream and sugar, 343 Sunburst jug, 1428 Warwick individual candleholders/Cobalt, 4225 one pint Cobel cocktail shaker with "Us" etch, 1503 Crystolite puff box, 2323 Navy 5 oz. soda, 3362 high footed Charter Oak comport/Moongleam, 1488 Kohinoor 2 light candlesticks, 806 colonial 1 ½ pound candy or cracker jar, two #1 Madonnas frosted and clear, 4220 Janice vase/Flamingo, #2 Clydesdale, #1 Horsehead bookend, 1509 Queen Ann 5 o'clock 3 compartment relish with 503 Minuet etch, "Pillows" look-a-like rose bowl, all 5 colors of the 1252 Twist oval hotel cream and sugar sets, and much, much more.

A name was drawn by our guest Becky to receive the door prize of a Heisey 3350 Wabash goblet with 166 Mayflower etch. Mary was the lucky winner – congrats.

We passed the "hat" to feed our treasury – thank you to everyone! A 50/50 auction was held with items including Heisey "Table Talk" pages, a deck of green Animal cards, and many jars of Jean Will's homemade plum jam (always a best seller). Our newest member, Paul, offered up Heisey punch cups and other items for the auction also. Thanks to all donors and all buyers – it takes a village.

Our attendance numbered 18 including guests. Everyone was invited upstairs to enjoy dessert so we adjourned quickly and set to that task. Thank you to our hosts, the Luckes, who made everyone feel at home. Their collections are wonderful to see and we all felt so welcomed and well-fed. Thank you also to Tom Files for acting as President, Treasurer, and Auctioneer – a rather busy day for him!

Our July 18, 2009 meeting will be at the home of John and Trudy Mock in Omaha. They also have a great Heisey collection and it's always fun at their house on the golf course. Come join us and I mean that literally – we welcome new members. All our

meetings have good programs and are most enjoyable. All details and lots of other info and pictures can be found at our website www.greatplainsheiseyclub.org.

Hope to see everyone at the 2009 HCA Convention.



Heisey Collectors of Texas
Erma Hulslander

WOW, what can I say! What a way to be invited to the Heisey Collectors of Texas annual auction! The front of the invitation was a 1920's Chevrolet panel truck, with the driver saying, "Hop in your jalopy and motor on over because". On the inside of the invitation, "It is time for the Heisey Club of Texas etc., etc." Cindy Christenson, Imagination Consultant, created this most beautiful invitation! The truck on the front cover, the Museum in the faded background inside, and the registered Heisey Trademark on the back! Spectacular!

This was the most outstanding, clever, unique, etc. HCT Benefit Auction! With the help of Cindy's (our guest/visitor we met in January at Margie's meeting) talent, it truly made for a memorable day for all the HCT'ers in attendance!



HCT Bidder's Paddle

When we arrived, the first thing we saw when entering Sally's home, was a nice red tent in the back yard, with rows of chairs facing a podium, which even included a gavel. On each chair laid a bidder's paddle, and Sally said we could use it as a fan, if need be. Yes, it did get a little warm! Now the shape of this bidder's paddle was, who else, but the face of Augustus Heisey! Mr. Heisey, saying different sayings to encourage the bidder. I really liked the one "I fought in the Civil War, the least you could do is bid a little higher". Twelve different

sayings, another good one says it plain but clear, "Going once, going twice, to help the Museum a higher bid would be nice!" Next, Cindy was fast to let us know, that the number on the other side, was not only our bid number, but also is an important date in Heisey's history. How clever, which reminds me to tell ya'll, Cindy's business card says, "Bright Ideas to Go!" so now you know the "rest of the story!" And now our visitor Cindy knows more about the history of A.H. Heisey & Company, than most Heisey collectors!

We had two winners that knew what happen on the dates on their bidder's paddle. George Ann Powell had 1842, which was the date Augustus H. Heisey was born, and Charlie Baird had 1870, which was the date Augustus Heisey married Susan Duncan. Hurray!! Cindy did not make all of the dates that easy, how about 1831, that is the one I had? The Samuel D. King residence was built (future home of National Heisey Glass Museum) in 1831! Yes, all this is for Heisey Collectors of Texas, little Study Club! We had 15 members present and one visitor - Cindy, which we could have not done without! Our Auctioneer was our Prez, Greg Freeman, and once again Cindy was helping. Cindy was not only the spotter for Greg, but bringing all the wrapped and unwrapped pieces one at a time to the podium. As usual we had loads of fun out-bidding each other! And, our \$50 or more wrapped boxes had some real nice pieces of Heisey in them! Our total that day was \$1,600, which is creeping up. As of this writing we are up to \$1,700 which may still get a little higher before June. Thanks, to all of those who donated such wonderful Heisey pieces, and for the generosity of all the members. Our Prez Greg Freeman will present these checks to HCA at the June Convention.

I must tell you the tent held up in the wind, and the rain did not come until after the Auction was over! However, after we were in the closed-in patio enjoying all the home made pastries, Sally and Cindy made, suddenly, sirens started, seemed like forever! We were safe, just watching the weather on the TV, following the storm. We received a phone call from another member that could not make it to the auction, telling us to change the channel. He said that the Dallas Cowboys training canvas and steel building was crashing to the ground! Thankfully, only three men were seriously hurt. Miracles still happen, this day no one lost their life at Valley Ranch!

Classified Ads

Even though this was our Benefit Auction for the HCA Museum, we are still a "Study Club." When the auction was going on, each piece that was sold, Greg described the pattern number and name. Then, George McNiel stepped to the podium and shared with us a very special, and very rare 1503 Crystolite pressed goblet. Of course, many of us never even knew about this goblet, so this was a wonderful treat! Talking about George, he was the author of the book, "Heisey Crystolite, A Pictorial Directory," which he donated to HCA, and is sold at the Museum Gift Shop. We are very proud of George, that is not an easy task to undertake, but he did it!

Thanks to Sally and Cindy for an awesome day!

We will be in Fairview, TX, on July 11, just north of Dallas off of Hwy. 75. Hope to see ya'!!! Until then, Happy Heisey Hunting! God Bless! ♦

Advertising Guidelines:

Advertising: Ads may be mailed to: HCA Advertising, 169 W. Church St., Newark, OH 43055; faxed to (740) 345-9638; or e-mailed to curator@HeiseyMuseum.org. Whenever possible, please e-mail your ad. Include your MasterCard or VISA number and expiration date for billing purposes, or send a check. All ads must be prepaid. When mailed or faxed, ads should be typed or printed on white paper with dark ink. Please double space. Ads that are entered in a vertical column format may contain a maximum of 65 characters per line, including spaces & punctuation.

Classified: 20 cents per word (members), 30 cents per word (non-members), \$1.50 min., 1/8 page limit. Personal ads 1/8 page limit. Abbreviations & initials count as words.

Display Ads:	member	nonmember
1/8 page (12 lines)	\$ 20	\$ 30
¼ page (25 lines)	\$ 40	\$ 60

½ page (60 lines, horizontal or vertical)	\$ 80	\$ 120
---	-------	--------

Full page (120 lines)	\$160	\$240
-----------------------	-------	-------

A charge of \$1.60 will be added for each additional line.

½ page: 4½" high by 7½" wide or 9" high by 3½" wide

Full page: 9" high by 7½" wide

Ad copy must be received by the first of the month prior to publication. Reproductions (i.e., Heisey by Imperial) must be indicated. Heisey News accepts no further liability. In the event of a typographical error, the incorrect portion of the ad will be run in the following issue, but HEISEY NEWS assumes no further liability.

Abbreviations: DF=Dolphin Foot NO=Narrow Optic
DO=Diamond Optic SO=Spiral & Saturn Optic
MO=Medium Optic WO=Wide Optic

39th Annual
PREMIERE GLASS SHOW

Featuring 40 prominent elegant glass dealers from across the U.S.

OSUN/COTC Campus, Country Club Drive, Newark, OH
30 miles east of Columbus off St. Rd. 16

Sponsored by Heisey Collectors of America, Inc.

In conjunction with
38th HCA National Convention

Artistry in Glass: the Heisey Etchings
June 17-20, 2009

Thursday, June 18, 1:00 p.m. - 7:00 p.m., \$5.00
(Ticket sales start at 11:30 a.m.)
Friday, June 19, 12:00 noon - 5:00 p.m., \$5.00
Saturday, June 20, 12:00 noon - 5:00 p.m., FREE

Museum Open House with FREE admission
Tuesday June 16 - Sunday June 21

Other Convention events to include:
Annual Meeting, Special Auction,
ID Session / Show & Tell,
Former Heisey Employees' Reception

For more info: (740) 345-2932, www.heiseymuseum.org

Proceeds benefit the National Heisey Glass Museum



Flea Market On The Square
Saturday, June 20th – 8am to Noon
Downtown Newark, OH
2009 Heisey Convention Event

Remember the fun and Heisey hunting of past conventions when people could set up on the Square and sell their glass? Relive the excitement on the Square in downtown Newark!

The Northern Illinois Heisey Study Club is proud to present the ALL GLASS Flea Market on the Square with **NO SET UP FEE**. You can get as much space as you need. Bring whatever size and quantity of tables you need. Sellers will start getting their space assignments at 7 am but no glass on the tables until 8 am. Remember **Glass only please**.

This event is a HCA event and while there is no set up fee, we will be sending around a representative to accept donations for the benefit of the HCA museum. Contact any of the following for more details and information:

Michael Maher (740) 763-4256 carolyn53@webtv.net	Kim Carlisle (317) 758-5767 kcarlisl@worldnet.att.net
Charlene Bowman (937) 289-2114 twoclbs@aol.com	
Joey Cogdill (864) 228-4741 hizhuntr@charter.net	Jeff Morrow (630) 833-4644 jmorrow64@comcast.net



Heisey Cambridge Footstar Imperial Paden City Tiffin Morganstown Duncan & Miller More



OUTSTANDING 2-DAY THIRTY-NINTH ANNUAL

ALL HEISEY AUCTION

Tuesday June 16, 2:00 P.M.

Wednesday June 17, 9:00 A.M.

Apple Tree Auction Center, 1616 West Church Street, Newark, Ohio 43055
740-344-4282

We have received the large collection of the late Frank and Marjorie Harper of White Fish Bay, Wisconsin. Frank and Marge were long time collectors. The largest collection of candlesticks and candelabra we have ever offered. Over 120 pairs including 2 sets of 1183 Revere 4 light, 3, 4 & 5 light candelabra, Gothic, Classic, 141 Edna U shaped, Sandwich dolphins in cobalt, amber, and Moongleam, Moongleam petticoat dolphins, electro portable lamp, great selection of candy jars and baskets, incl Aristocrat candy jar in Cobalt, over 100 pieces each in Sahara, Moongleam and Flamingo. Scarce pieces in Tangerine and Alexandrite as well as a good selection of other colors. 2 rare mail boxes, animals and animal related including honey amber flying mare (leans), show horse, wood duck, swan, Clydesdale, gazelle, and 60 other animals, bantam rooster, seahorse, rooster, goose, pony, and other stems, goose and penguin decanters. Several pieces of colored Verly's, over 100 lots of Heisey by Imperial and other companies. Good selection of Pied Piper, Rose, Orchid etch, Old Sandwich, Lariat, Victorian, Suez with Peach Tree cutting. Over 20 different deep plate etch old fashions incl 3 little pigs, golfers, skier, Winchester, motorboat, sailboats and other deep plate etchings. 250 pcs Ridgeleigh, 150 pcs Crystalite, 140 pcs Plantation, and 70 pcs Greek Key. You may send \$6.00 for catalogs, go to our website, or call for more details. Don't miss this great auction. www.appletreeauction.com Doors open noon on Tuesday. Sam Schnaidt and David Schnaidt Auctioneers.

Our June 11 - 13 three day antique auction will also feature several hundred lots of Heisey and Heisey by Imperial as well as lots of other Ohio Valley glass.

◆ *Paid Ad*

34th Annual
**National
Cambridge
Collectors
GLASS SHOW AND SALE**
(and 36th Annual NCC Convention)
PRITCHARD LAUGHLIN CIVIC CENTER
Interstate 70 - Exit 176
1/2 Mile East on Route 40
Cambridge, Ohio
JUNE 26 & 27, 2009

Hours:
Friday, June 26 - PREVIEW - 12:00 pm to 5:00 pm
Admission \$10.00
Saturday, June 27 - 11:00 am to 4:00 pm
Admission \$5.00

Featuring Cambridge and other fine glassware including
Heisey, Imperial, Fenton, Duncan, Tiffin and others.

Other events open to the public include:
Educational Programs and Glass ID Session

GLASS DASH - GLASS FLEA MARKET
Saturday, June 27 (7 am - 8:30 am; \$10.00 - 8:30 am - 11 am; \$3.00)
Beech Grove Family Center- Route 209 South

Visit the
NATIONAL MUSEUM OF CAMBRIDGE GLASS
136 S. 9th St., Downtown Cambridge, Ohio
740-432-4245

Info - National Cambridge Collectors, Inc.
P.O. Box 416
Cambridge, Ohio 43725
www.cambridgeglass.org

◆ *Reciprocal Ad*

The National Depression Glass Assn. Inc.

**National Depression Glass Association
35th Annual Convention
Glass Show & Sale**
Sat, July 11, 2009 • 10 am - 5 pm
Sun, July 12, 2009 • 11 am - 4 pm

**O'NEILL CENTER
WESTERN CONNECTICUT STATE UNIV
DANBURY, CT**
OFF I-84 EXIT 4

FREE PARKING • HANDICAP ACCESSIBLE
EARLY BIRD ADMISSION SAT. 8-10 am
\$8 GENERAL ADMISSION

GUEST AUTHORS: BARBARA & JIM MAUZY
"MAUZY'S DEPRESSION GLASS"

GLASS SEMINARS GLASS DISPLAYS

FOR MORE INFORMATION Convention@NDGA.net
CALL 516-476-0155 WWW.NDGA.NET

◆ *Reciprocal Ad*

Dealer Directory

Maximum 6 lines/12 months/\$35 MEMBERS ONLY

Contact the Editor to place your ad!



<p>KIM & PAM CARLISLE SHOWS & MAILORDERS ONLY 28220 Lamong Rd. Dept. H Sheridan, IN 46069 Glass Cleaning Services Available (317) 758-5767 kcarlisl@worldnet.att.net</p>	<p>SHIRLEY EUGENIA DUNBAR Heisey a Specialty—Mail Order, Shows, Appraisals EMAIL: shirley400@aol.com PO Box 8344, Port St. Lucie, FL 34952 Oct-May (772) 337-1558 PO Box 222, Naples, ME 04055 May-Oct (207) 647-5652</p>	<p>SUM OF LIFE Elaine Husted: 610-469-1243 Traveling through eastern PA Call, stop in, be a buyer or a browser!! E-mail: 1classycat@comcast.net</p>
<p>ALL HEISEY AUCTION Consignments Welcome Apple Tree Auction Center 1616 W. Church, Newark, OH 43055 (740) 344-4282</p>	<p>MOUNDBUILDERS SECOND GENERATION Barbara and Richard Bartlett Heisey Exclusively! 1-904-280-0450 PO Box 1931, Ponte Vedra Beach, FL 32082 Toll Free 1-888-434-7397(HEISEYS) EMAIL: CLASYGLAS2@AOL.COM</p>	<p>EAGLES REST ANTIQUES <i>Buying Heisey, China & Pottery</i> Carl and Mary Evans 62 Fieldpoint Rd., Heath, OH 43056 (740) 522-2035</p>
<p>PAULA & JEFF MORROW Elegant Glassware and American Dinnerware 126 Clinton Avenue Elmhurst, IL 60126 (630) 833-4644 mor-fab@comcast.net</p>	<p>H & R DIAMOND H Helen & Bob Rarey 1450 White Ash Dr. Columbus, OH 43204 (614) 279-0390 after 5:30</p>	<p>CRYSTAL LADY Bill, Joann & Marcie Hagerty Specializing in elegant depression glassware 1817 Vinton St., Omaha, NE 68108 Shop (402) 341-0643 or Home (402) 391-6730 Email: ejhagerty@aol.com website:www.crystalladyantiques.co</p>
<p>REALMS IN GLASS Roy Eggert Heisey Custom Stained Glass 12009 Fingerboard Rd, Monrovia, MD 21770 301-865-5196 roy54@hughes.net</p>	<p>PIECE BY PIECE ANTIQUES Buy & Sell Specializing in Heisey Glassware Bryan K. Baker Fairfax Station, VA 22039 Newark, OH 43055 (703) 250-6117 piecebypiece@verizon.net</p>	<p>PATTON HOUSE ANTIQUES Specializing in Glass*Heisey*Cambridge*Fostoria*Duncan* Factory Antique Mall, Verona, VA off I-81 Exit 227 Antiquers Mall, Booth 81, Rt. 29 N., Charlottesville, VA The Daniels, Box 547, Louisa, VA 23093 (540) 967-1181</p>
<p>C&J ANTIQUES Cole & Jean Miesner Box 45, 72 Whig St. Newark Valley, NY 13811 (607) 642-9905</p>	<p>SIBYLS OF WILMINGTON Sibyl & Ned Lavengood at Castle Corner Antiques 555 Castle St. Wilmington, NC (910) 264-9597 or Sibylsantiques@bellsouth.net</p>	<p>FRAN'S FANCY FINDS Fran & Jack Grenzebach 10534 Valencia Rd., Seminole, FL 33772-7511 (727) 391-5184 SHOWS MAIL ORDERS</p>
<p>The American Bell Association P.O. Box 19443 Indianapolis, IN 46219-0443 www.americanbell.org m</p>	<p>PASTICHE ANTIQUES at Preston's Antique Gaslight Village US 12, Allen, MI 49227 Elegant Glass and Other Fine Antiques pasticheantiques@gmail.com</p>	<p>WILLEY'S ANTIQUES & MUSEUM Specializing in Heisey 11110 Cannon Rd., Frazeytsburg, OH 43822 16 miles east of Newark, OH (740) 828-2557</p>
<p>CHARLES & MILDRED FISHER Heisey animals and Heisey By Imperial animals 1607 Dayton Rd, Newark, OH 43055 Cfisher08@roadrunner.com (740) 281-3104</p>	<p>MARSH'S ANTIQUES Dick and Virginia Marsh 4532 Newton Road Newark, OH 43055 swamp@alink.com (740) 366-5608</p>	<p>MOONGLEAM ANTIQUES Heisey Glassware & American Art Pottery John Woytowicz and Peter Rivard 70 Pleasant St., Gardiner, ME 04345 (207) 582-9048 E-mail: jmwpwr@aol.com</p>
<p>ROBERT M. LOCH Voting Member HCA and NWHC Pacific Interstate Glassware Co. PO BOX 469 Custer, WA 98240 360-366-3166</p>	<p>CRESTONE MANOR UNIQUES Harold & Loleta Hammontree 3317 Crestone Circle, Chattanooga, TN 37411 423-629-1274 hammonl@bellsouth.net Heisey Only</p>	<p>APPLE VALLEY COLLECTIBLES Richard & Marilyn Garnett – Owners Shows/ Mail Order (845) 691-6308 Email: diamondH95@aol.com</p>
<p>DOWNSTAIRS AT FELTON ANTIQUES 100B Felton St, Waltham, MA 02453 781-894-2223 info@feltonstreetantiques.com GLASSWARE, POTTERY, EPHEMERA, STERLING, FURNITURE FROM EVERY DECADE!</p>	<p>WM GLASS Bill & Mary Barker 400 Nantucket Ave., Pickerington, OH 43147 (740) 927-0918 mcbarker@embarqmail.com Heisey Only</p>	<p>WATERSEdge ANTIQUES Norene & Don Walzer Shows & Mail Order 25089 Riverwalk Drive Leesburg, FL 34748 (352) 314-8975 dnnwalzer@embarqmail.com</p>
<p>JERRYS' ANTIQUES Shows Only Glassware and Other Fine Collectables PO Box 4485, Davenport, IA 52808 563-340-1871 jerrysantiques@mchsi.com</p>	<p>ONCE AND FUTURE ANTIQUES Susan & Stephen Pescatore 9 Donna Rd. Chelmsford, MA 01824 (978) 256-5418 Heisey and Elegant Glass</p>	<p>BOB & MARY KREIMER Specializing in Heisey Glass 7044 SW 116th Loop, Ocala, FL 34476 (352) 873-8306 email: rkreimer@earthlink.net. Shows and Mail Orders Only</p>
<p>J & L TREASURES Specializing in Heisey, Cambridge, Fostoria, Tiffin, Morgantown, etc Linda Kilburn, PO Box 1257, Burlington, CT 860-673-4088 jltreasures@comcast.net</p>	<p>Charlene Bowman Shows Only Heisey – Cambridge – Fostoria - Morgantown P.O Box 287, Clarksville, OH 45113 937-289-2114 twoclbs@aol.com</p>	<p>YELLOW BRICK ROAD ANTIQUES Jean Will Leavenworth, KS 66048 (913) 682-4831 Specializing in Heisey and Elegant Glassware Shows and Estate Sales</p>
<p>Just in Time Antique Mini Mall 29 North Third St Newark, OH 43055 Heisey in Stock 740-349-0001 ntleblanc@aol.com</p>	<p><i>Your Ad Could be Here</i></p>	<p><i>Your Ad Could be Here</i></p>

When Renewing Your Membership

Help ensure the future of your Museum. When you renew your membership at one of the levels below, any amount beyond the regular Associate dues goes into the Endowment Fund.

<i>Individual Contributing, one person in household</i>	<i>\$50</i>
<i>Joint Contributing, two people in one household</i>	<i>\$60</i>
<i>Family Contributing, parents and children under 18</i>	<i>\$75</i>
<i>Patron</i>	<i>\$125</i>
<i>Sponsor</i>	<i>\$250</i>
<i>Benefactor</i>	<i>\$500</i>

Visit The
National
Heisey
Glass
Museum



Come at your leisure to enjoy more than 4,800 pieces of glassware produced by A.H. Heisey and Company from 1896-1957. Hundreds of patterns are featured in all production colors. Rare and experimental items are included as well.

Facilities are air-conditioned and handicapped-accessible. Hours are 10:00 a.m. to 4:00 p.m. Tuesday through Saturday, 1:00 to 4:00 p.m. Sunday (except Jan. and Feb.). Members are admitted free, regular admission is \$4. Office hours are 8:00 a.m. to 4:30 p.m. weekdays.

Membership Renewal Notice: Check the date above your name and address on the mailing label. This is your expiration date. If it reads 6-10-09, make sure your dues are paid soon in order to receive next month's issue of *Heisey News*.

Contact the HCA Administrative Office at (740) 345-2932 for more information. The Endowment Committee wishes to thank those who have become Endowment Members and all of the individuals and study clubs that have so generously supported the HCA Endowment Fund. All members who have supported the fund are recognized each year in the February issue of the Newsletter. Your support will make the Museum self-sustaining in the years to come. Thank You all! ♦

Shipping & Handling Fees for Outside US

Additional shipping charges are required for members living outside the U.S. Current rates are Canada, \$22; for other countries, contact the Museum. Rates are subject to change at any time due to rate changes made by the US Postal Service. To verify current rates, call (740) 345-2932 or E-mail business@HeiseyMuseum.org



Periodical Postage

Paid at the Post Office
In Newark, OH 43055
Publication # 00986
POSTMASTER SEND FORM 3579 TO:
HCA
169 W. Church St.
Newark, OH 43055

To: _____

Museum Volunteers for April 2009

Chuck & Amy Jo Jones

Frank Kuhlmann

Dick Marsh

Phyllis McClain

Don & Pat Moore

Sharon Orienter

Ginny Priest

Russ Reopell

Judy Rhoads

Emogene Shomaker

Dick & Marilyn Smith

Dave & Mary Ann Spahr

Charlie & Susan Wade